



EVO G-MAX
機車零件目錄

EVO
Turbo
G-MAX
SCOOTERS

PGO *SCOOTERS*

序 言

93 年 10 月一版

本零件目錄主要適用於 G-MAX 125 (代碼為 M2-125) 及 G-MAX 150 (代碼為 M2-150) 機型,當您要訂購零件時,請參考這本零件目錄,並請正確地引用零件號碼和零件名稱。

- 一、本零件目錄之發行主要是作為 G-MAX 125 (代碼為 M2-125) 及 G-MAX 150 (代碼為 M2-150) 機型上市之後,售後服務零件之修補及各零組件組合關係之依據,俾便於售後服務業務之推展。
- 二、在本零件目錄發行後,若遇有修改、增訂時,請您依據設計變更通報和服務通訊,及時更新您的零件目錄,以保持準確度。
- 三、規格欄位內包含多種機型代號,茲分項說明如下:
 - G-MAX 125 (代碼為 M2-125) 引擎號碼自 C1MF00001 起
 - G-MAX 150 (代碼為 M2-150) 引擎號碼自 C5MF00001 起
- 四、價格欄位內標示金額者,代表本公司之最終建議售價(含稅,不含工資),請各經銷體系通力配合之。
- 五、噴漆色彩件之請購,請參考配色表之外觀件件號,並需增加顏色碼於件號中。
- 六、價格之異動以本公司通知書或發貨單為準,個別零件或細微之零件價格變動者,恕無法個別通知。

摩特動力工業股份有限公司
品保中心服務課 編製

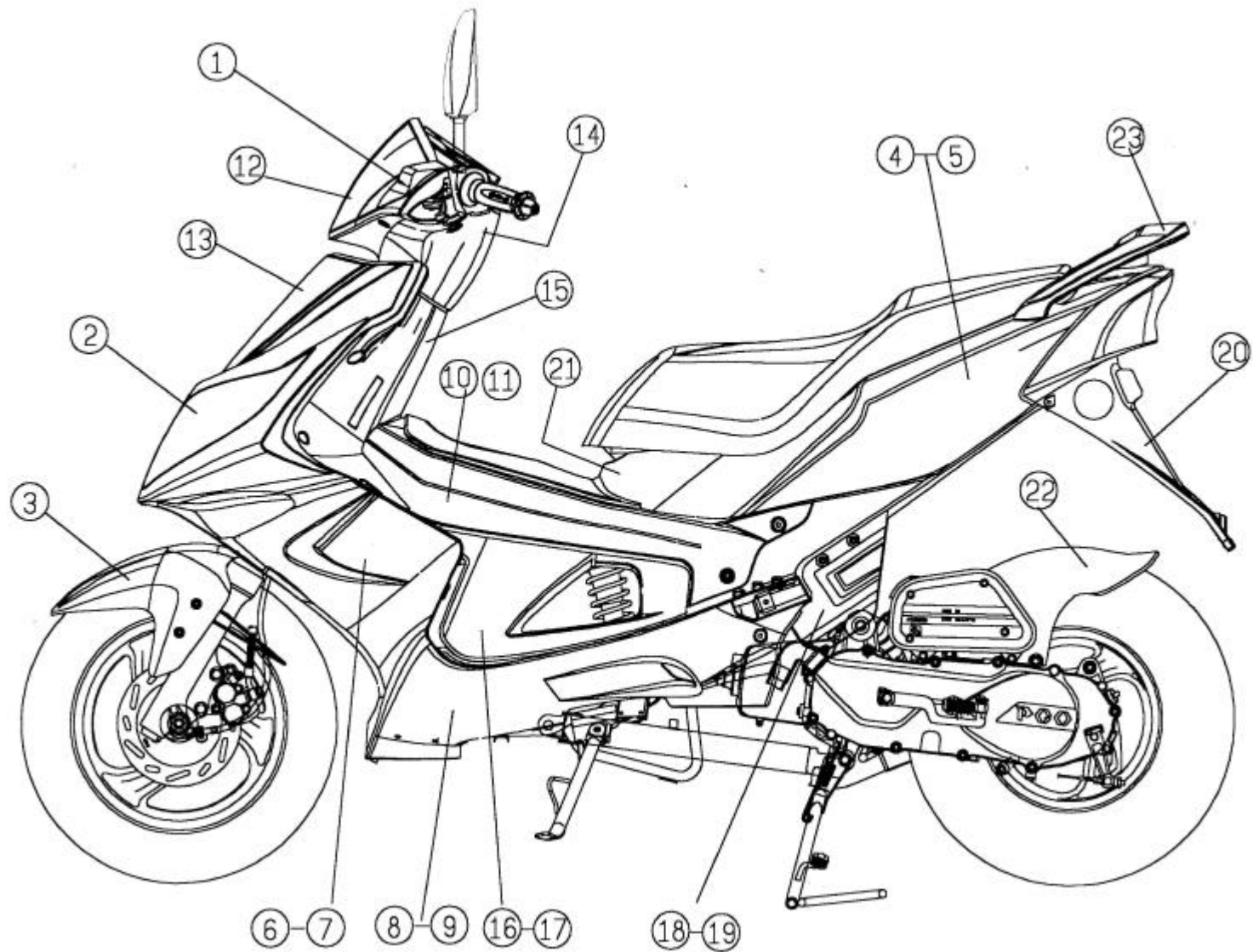

G-MAX機型外觀件顏色零件號碼速查表

G-MAX COLOR CODE FOR OUTLOOK PARTS

項次 ITEM	名稱	PART NAME	備註 REMARK	曠野灰(7N0) GRAY	冰晶銀(7L0) ICE SILVER	勁火紅(1N0) FIRE RED	星河藍(4W0)	建議售價
1	方向把手上蓋	HANDLE COVER UPPER		M26130007N0	M26130007L0	M26130001N0		333.0
2	擋風板	WINDSHIELD		M26210007N0	M26210007L0	M26210001N0		500.0
3	前土除	FR FENDER	M2-50	C16320027N02	C16320027L02	C16320021N02		260.0
3	前土除	FR FENDER	M2-125/150	M26320007N0	M26320007L0	M26320001N0		260.0
4	左車身蓋	BODY COVER,LH		M26253007N0	M26253007L0	M26253001N0		360.0
5	右車身蓋	BODY COVER,RH		M26255007N0	M26255007L0	M26255001N0		360.0
6	前方向燈飾蓋(左)	TURN SIGNAL FRONT ASSY,INNER COVER(LH)		M2621300690	M26213007L0	M26213001N0		200.0
7	前方向燈飾蓋(右)	TURN SIGNAL FRONT ASSY,INNER COVER(RH)		M262A300690	M262A3007L0	M262A3001N0		200.0
8	下護蓋(左)	LOWER COVER(LEFT)		M26263007N0	M26263007L0	M26263007L0		300.0
9	下護蓋(右)	LOWER COVER(RIGHT)		M26265007N0	M26265007L0	M26265007L0		300.0
10	龍骨蓋(左)	KEEL COVER,LH		M26240107L0	M26240107L0	M26240107L0		230.0
11	龍骨蓋(右)	KEEL COVER,RH		M262D0107L0	M262D0107L0	M262D0107L0		280.0
12	遮陽板	AGAINST SUN PLATE		M2613020000	M2613020000	M2613020000		100.0
13	擋風板飾蓋	WINSHIELD,OUTER COVER		M2621010690	M2621010690	M2621010690		220.0
14	方向把手下蓋	HANDLE COVER LOWER		M2614000650	M2614000650	M2614000650		100.0
15	前內蓋	INNER COVER,FRT		M2623000650	M2623000650	M2623000650		280.0
16	腳踏板(左)(超黑)	STEP FLOOR,LH		M2624000650	M2624000650	M2624000650		100.0
17	腳踏板(右)(超黑)	STEP FLOOR,RH		M262D000650	M262D000650	M262D000650		100.0
18	左吊架飾蓋	LEFT HANGER COVER		M2624060650	M2624060650	M2624060650		20.0
19	右吊架飾蓋	RIGHT HANGER COVER		M2624070650	M2624070650	M2624070650		20.0
20	牌照板	LICENCE PLATE		M2636000650	M2636000650	M2636000650		80.0
21	油箱飾蓋	FUEL TANK COVER,FR.		M2625010650	M2625010650	M2625010650		100.0
22	後土除 (超黑色)	REAR FENDER	M2-50	P2634000650	P2634000650	P2634000650		78.0
22	後土除(超黑)	REAR FENDER	M2-125/150	M2634000650	M2634000650	M2634000650		120.0
23	後行李架	RR LUGGAGE BRACKET		M26760007L0	M26760007L0	M26760007L0		810.0

引擎部份 圖目錄

E1 曲軸箱
CRANK CASE

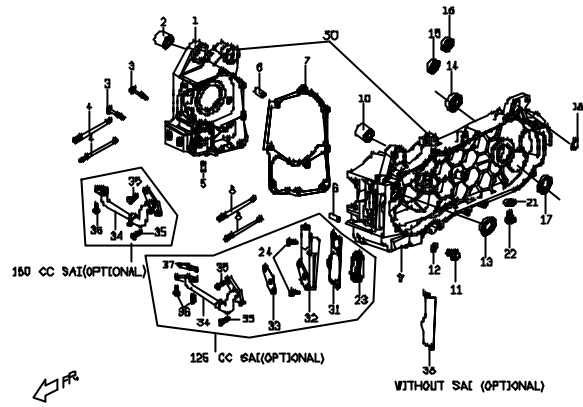

P.1

E2 左邊蓋
LH SIDE COVER

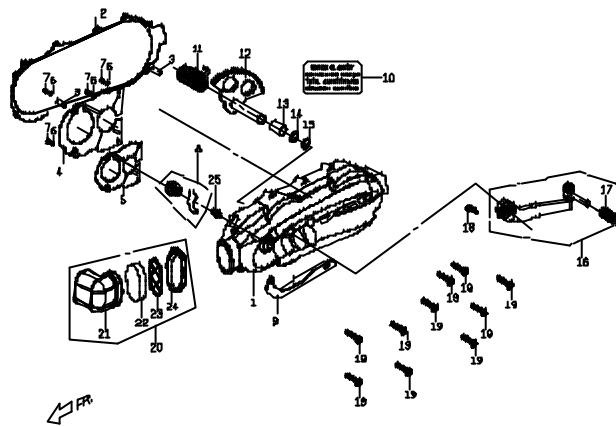

P.3

E3.1 汽缸頭 (125 CC)
CYLINDER HEAD

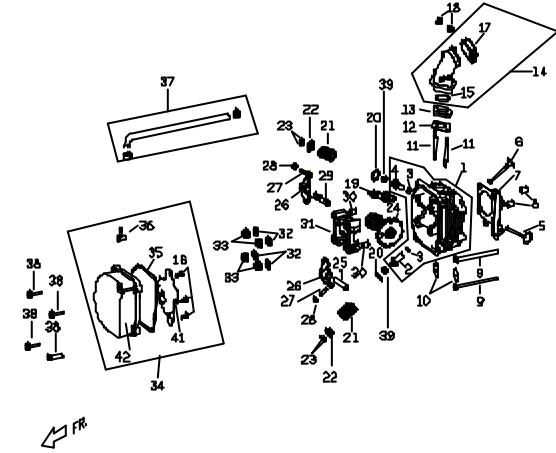

P.4

E3.2 汽缸頭 (150 CC)
CYLINDER HEAD . CYLINDER HEAD COVER

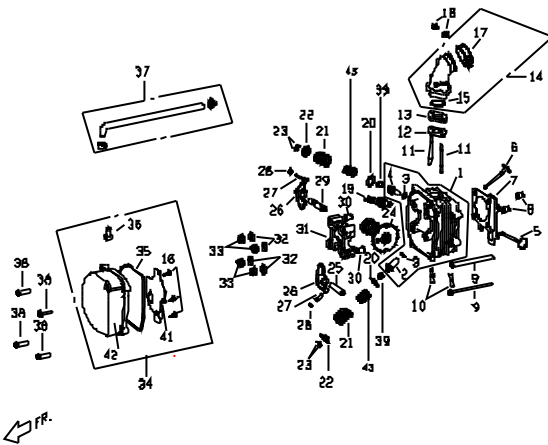

P.6

E4.1 曲軸及汽缸 (125 CC)
CYLINDER . PISTON . CRANKSHAFT

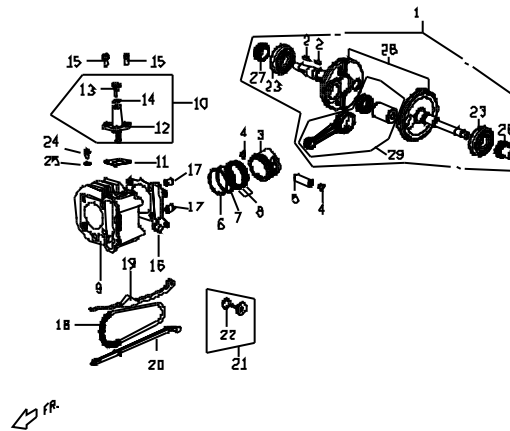

P.8

E4.2 曲軸及汽缸 (150 CC)
CYLINDER . PISTON . CRANKSHAFT

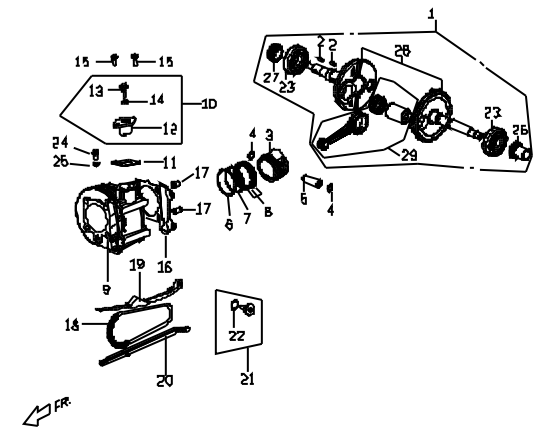

P.9

引擎部份 圖目錄

E5 右曲軸箱蓋
RIGHT CRANKCASE COVER

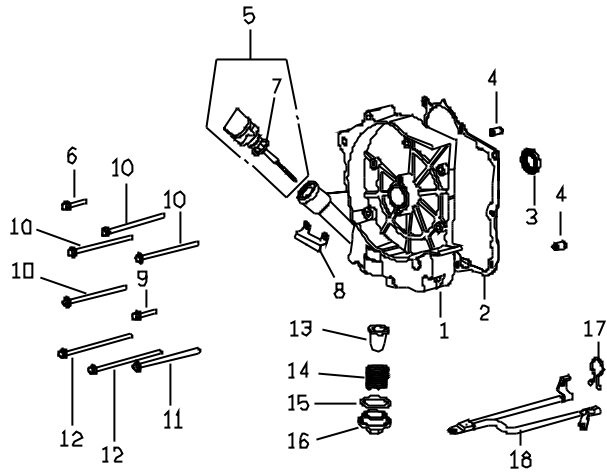

P.10

E6. 化油器
CARBURETOR

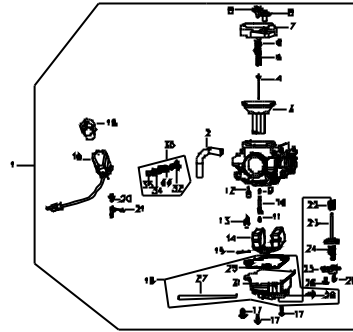

P.11

E7 自動變速系統
CVT TRANSMISSION

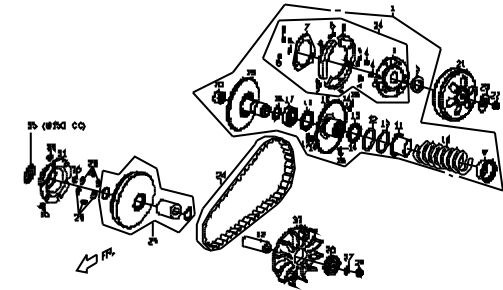

P.13

E8 發電機 / 風扇罩
FAN COVER, GENERATOR

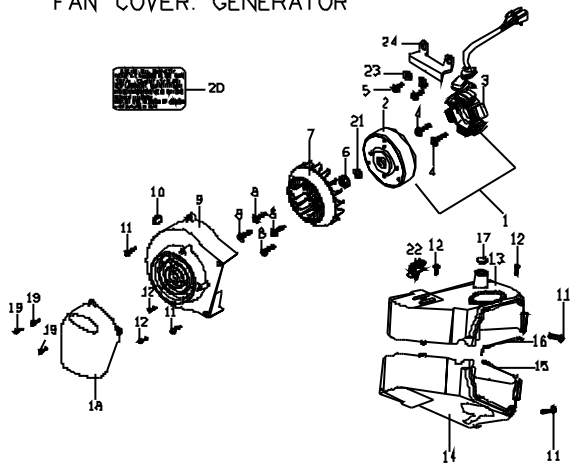

P.15

E9 起動馬達
STARTING MOTOR, OIL PUMP

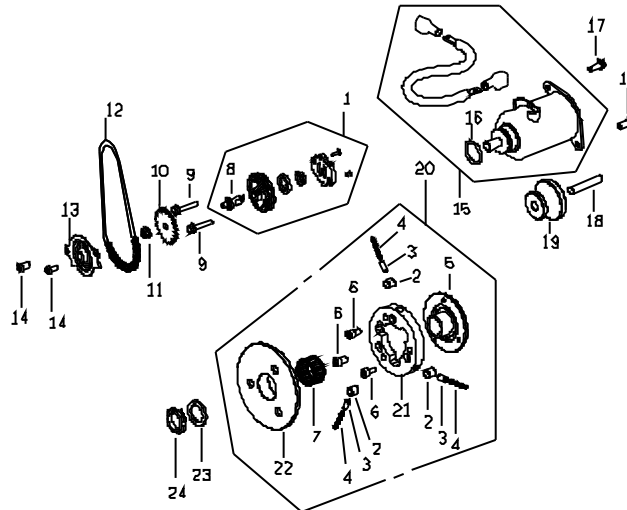

P.16

E10 傳動齒輪箱
GEAR TRANSMISSION

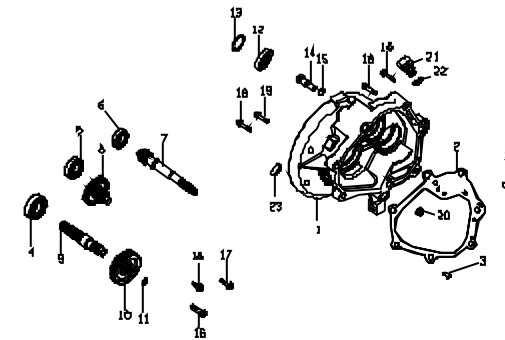

P.17

引擎部份 圖目錄

E11. 空氣濾清器組合(有EEC)
AIR CLEANER COMP.
W/H EEC SYSTEM

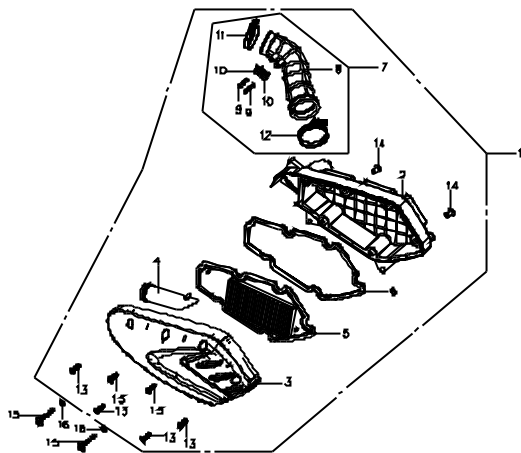

P.18

E12 消音器
MUFFLER

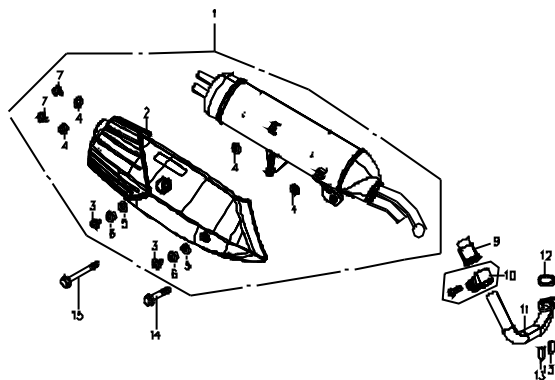

P.19

E13後輪 REAR WHEEL

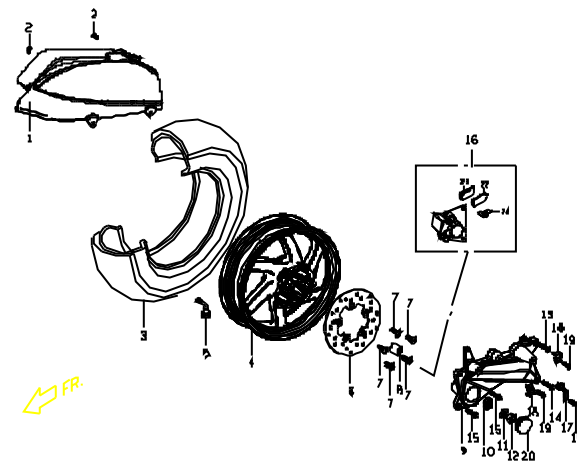

P.20

E14. 機油冷卻器
OIL COOLER & LH COVER

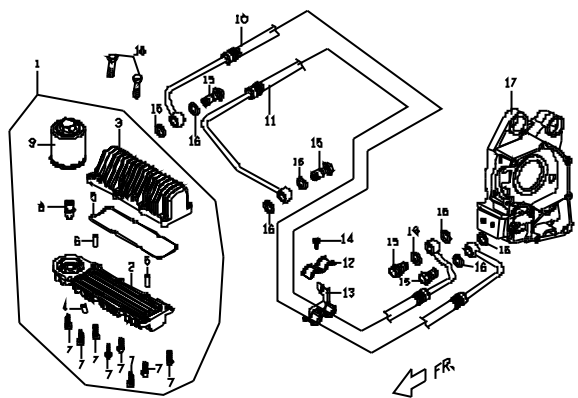

P.21

E15 空氣導入控制閥總成
AIAC ASSY. (OPTIONAL DEVICE)

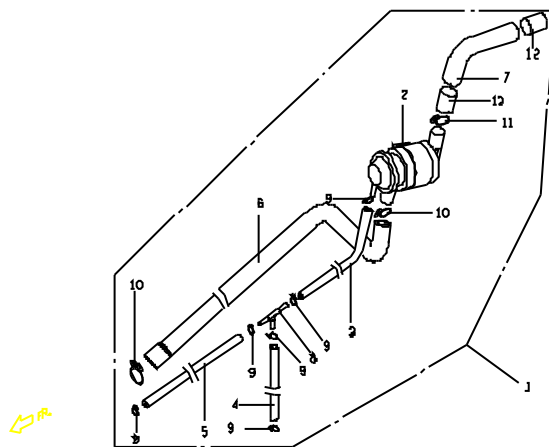

P.22

P.20

車身部份 圖目錄

F1 方向把手前後蓋。方向把手管。遮陽板
COVER UPPER & LOWER HANDLE BAR.
SUN PLATE.

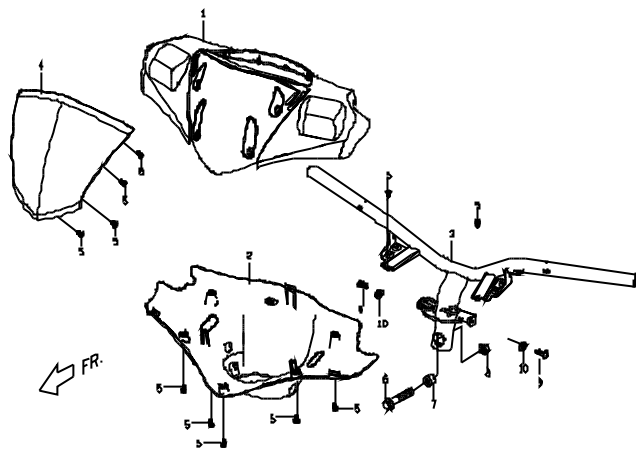

P.23

F2 碼錶
SPEEDOMETER

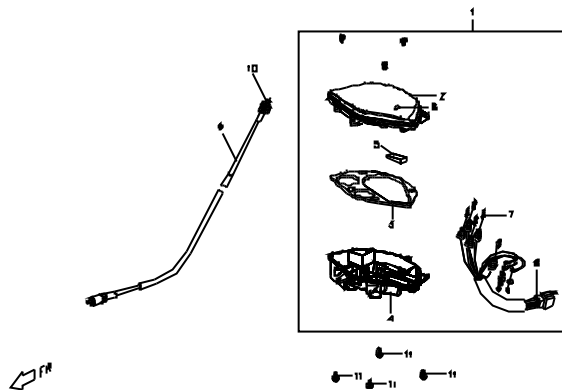

P.24

F3.2 導線開關。後視鏡 (前碟後碟)
CABLE SWITCH BACK MIRROR

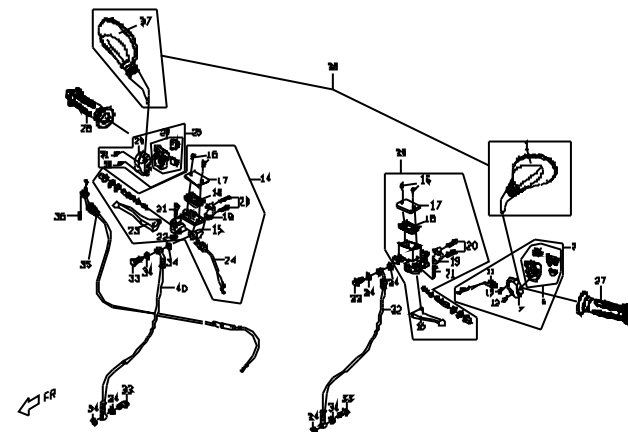

P.25

F 4.2 前叉 (125/150CC)
FRONT FORK

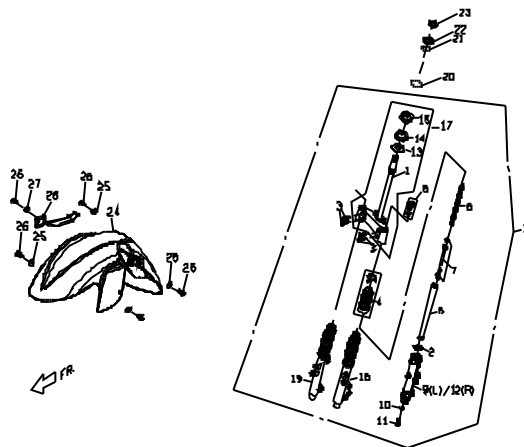

P.27

F5.2 輪胎。前輪圈。碟式煞車夾 (125/150c.c)
TIRE.FRT WHEEL.FRT CALIPER.

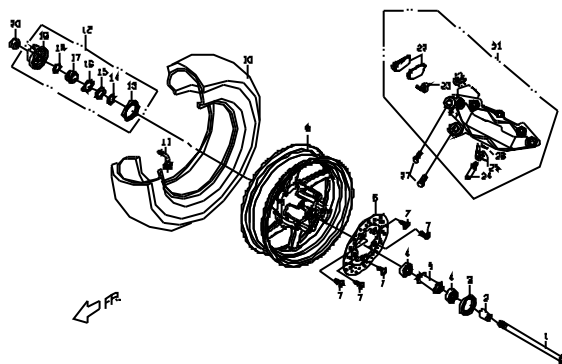

P.28

F6 擋風板。前內蓋。前大燈
WINDSHIELD.FRT INNER COVER.
FRT HEAD LIGHT.

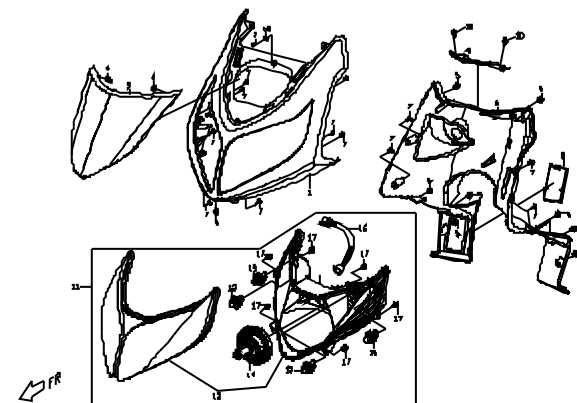

P.29

車身部份 圖目錄

F7 腳踏版。
STEP FLOOR.STEP PLATE.

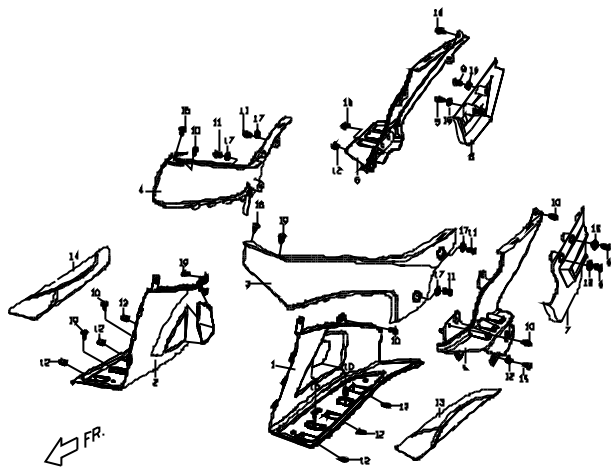

P.30

F8 前下蓋, 腳踏板下腹蓋, 前土除
FRT LOWER COVER.STEPFLOOR LOWER
COVER.FRONT FENDER

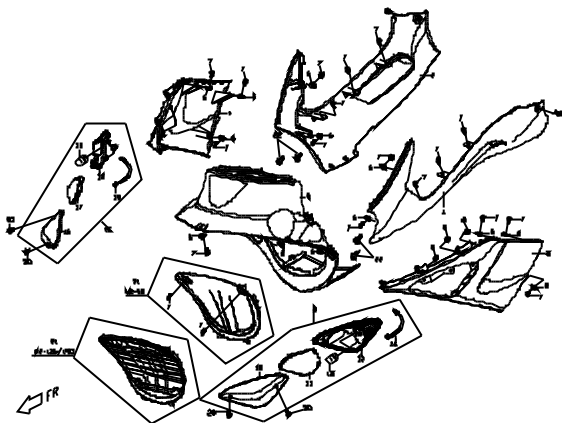

P.31

F9 車身蓋, 中間蓋, 後行李架, 車身下腹蓋。
BODY COVER.MIDDLE COVER.
RR LUGGAGE.BODY LOWER COVER.

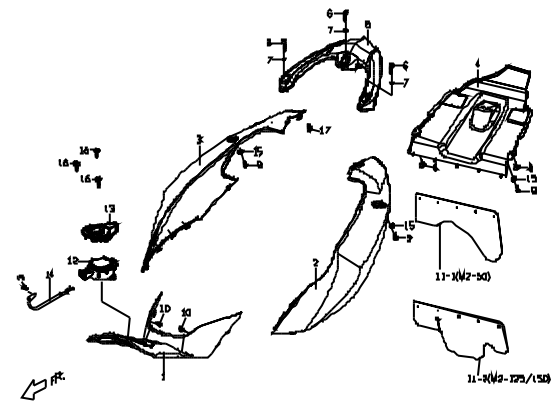

P.32

F10 座墊, 前置物箱, 後置物箱
SEAT.FR LUGGAGE.
BACK LUGGAGE .

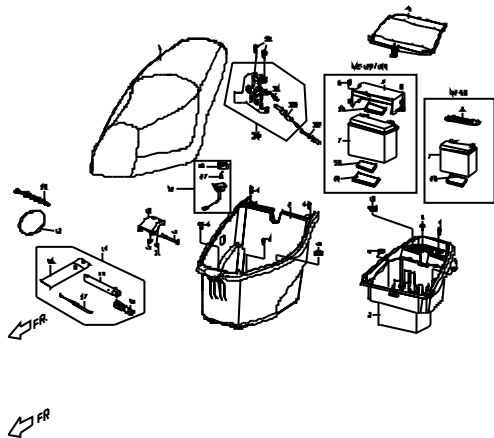

P.33

F11 牌照板, 反光片, 後燈。
LICENSE PLATE.REFLECTOR.
BACK LAMP.

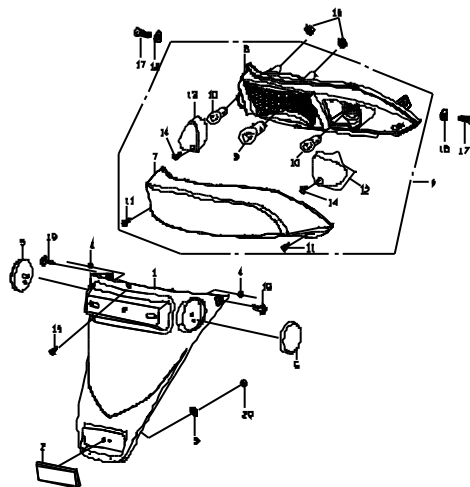

P.34

F12.2 車架 (125/150c.c)
FRAME

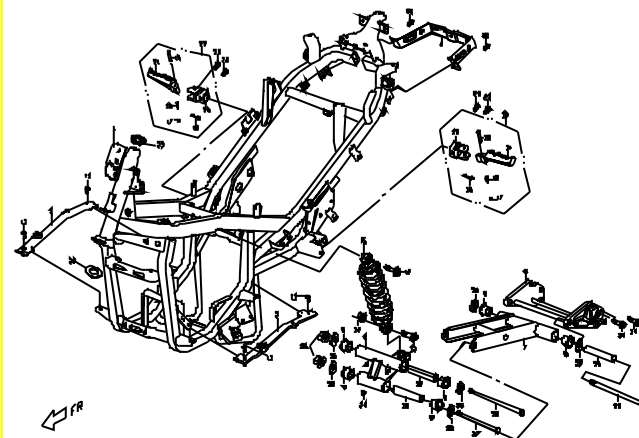

P.35

車身部份 圖目錄

F13 汽油箱
FUEL TANK

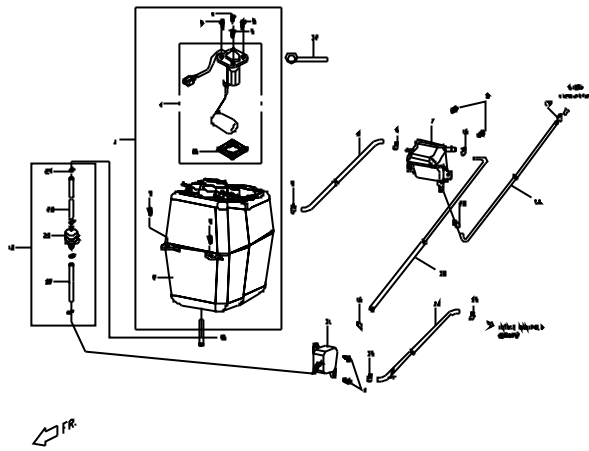

P.37

F14.2 中腳柱, 側腳柱
CENTER STAND, SIDE STAND

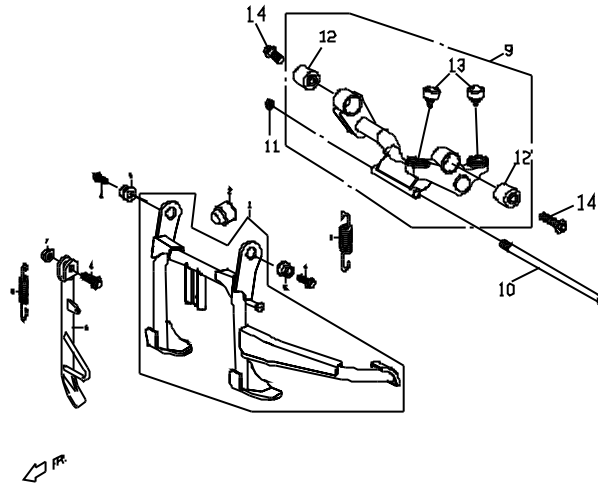

P.38

F15.2 主配線 M2-125/150
WIRE HARNESS

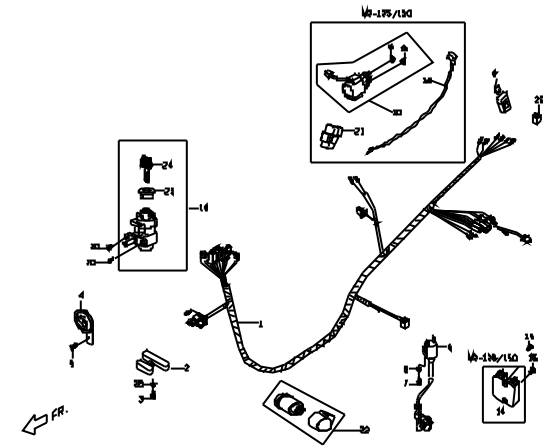

P.39

F16 貼紙
LABEL

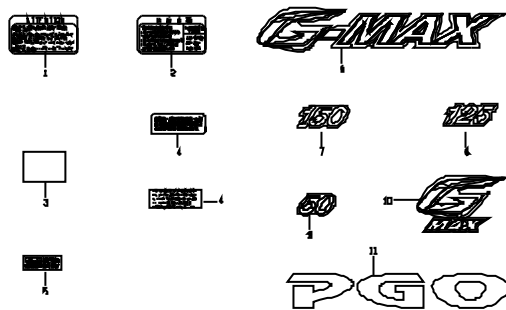

P.40

F17 燃料蒸發E.C.控制系统
E.E.C SYSTEM (OPTIONAL DEVICE)

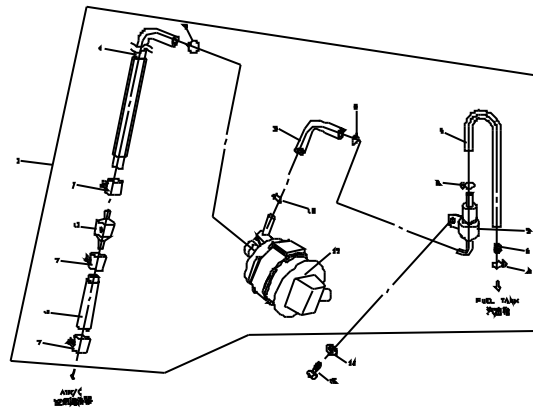

P.41

曲軸箱

E1 CRANK CASE

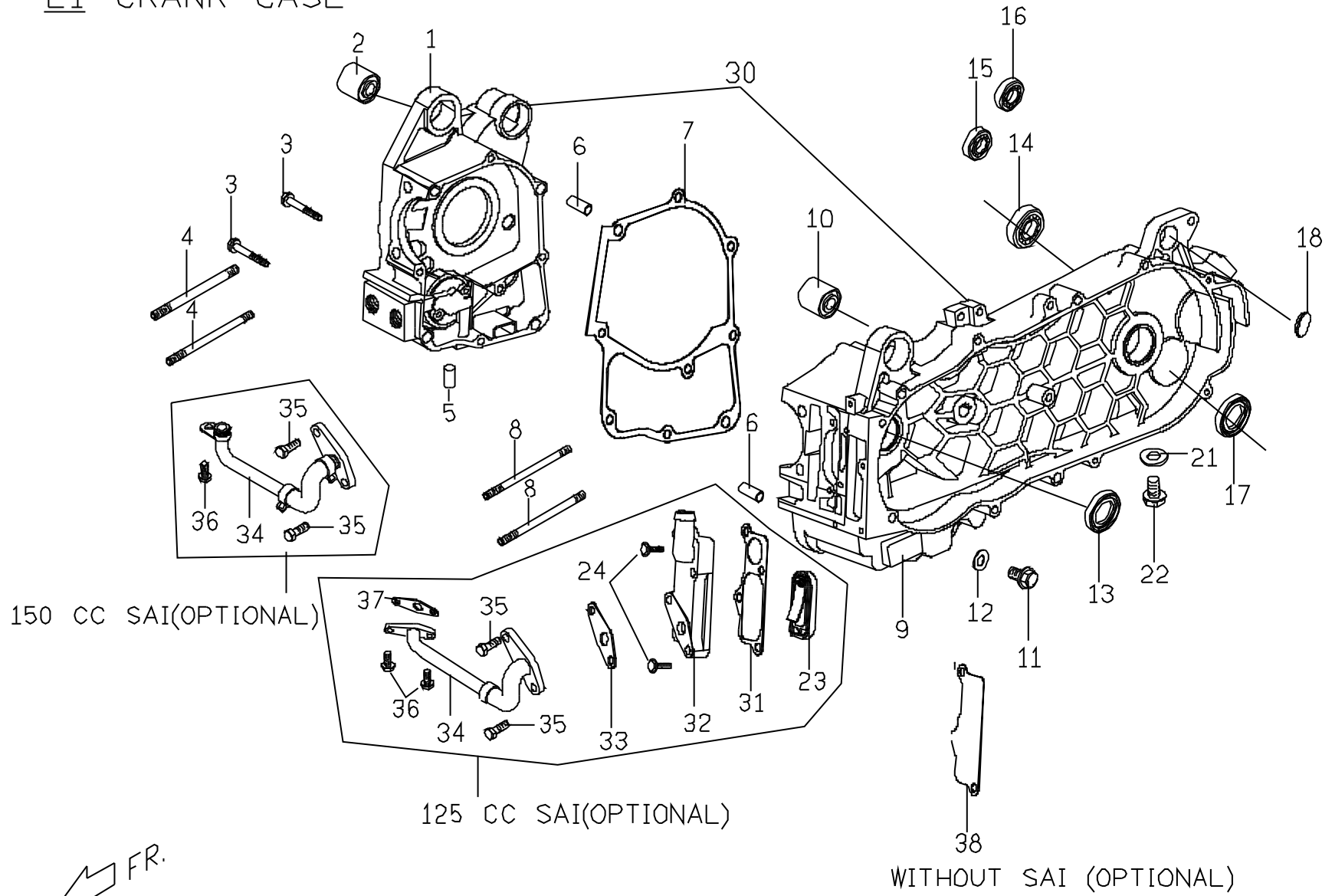

E1 曲軸箱 (CRANKCASE)

AVAILABLE FOR M2-125/150

No. 項目	Part No. 零件號碼	Q'TY 數量	PART NAME 零件中文名稱	PART NAME 零件英文名稱	SPECIFICATION 規格
1	C10610100001	1	右曲軸箱	RH CRANKCASE	M2-125
1	C5061011000	1	右曲軸箱	RH CRANKCASE	M2-150
2	E1061020000	1	防震襯套	RUBBER BUSH	
3	90190605003	2	六角凸緣螺栓	HEXAGON FLANGE BOLT	
4	90170818800	2	雙頭螺絲	STUP BOLT	
5	G1061070000	1	油塞	PLUG OIL	
6	93540801400	2	定位銷	LOCK PIN	
7	C5061040000	1	曲軸箱墊片	CRANKCASE GASKET	
8	90170819500	2	雙頭螺絲	STUD BOLT	
9	C10620100002	1	左曲軸箱	LH.CRANKCASE	M2-125
9	C50620100002	1	左曲軸箱	LH.CRANKCASE	M2-150
10	E1061020000	1	防震襯套	RUBBER BUSH	
11	90181201500	1	六角凸緣螺栓	HEXAGON FLANGE BOLT	DRAIN OIL
12	92141200006	1	平墊圈	PLAIN WASHER	
13	95572232601	1	TC形油封,(曲軸用)	OIL SEALTC TYPE	M2-125
13	95572032601	1	TC形油封,(曲軸用)	OIL SEALTC TYPE	M2-150
14	96510620402	1	深槽滾珠軸承(6204)	DEEP GROOVE BALL BEARING	
15	96510620200	1	深槽滾珠軸承(6202)	DEEP GROOVE BALL BEARING	
16	96510620301	1	深槽滾珠軸承(6203)	DEEP GROOVE BALL BEARING	
17	95572032600	1	TC形油封(\$ 32* \$ 19.5*6t)	OIL SEAL TC TYPE	FOR PULLEY
18	取消	1	塑膠塞	RUBBER PLUG	
21	92140800001	1	平墊圈	PLAIN WASHER	
22	90190801200	1	六角凸緣螺栓(M8*12L)	HEXAGON FLANGE BOLT	
23	C5286010000	1	進氣閥組合	SECOND AIR REED VALVE COMP	
24	90190602700	2	六角凸緣螺栓(M6*27L)	HEXAGON FLANGE BOLT	
30	C106K0100002	1	曲軸箱總成(左.右)	RH AND LH CRANKCASE ASSY.	M2-125
30	C506K0100002	1	曲軸箱總成(左.右)	RH AND LH CRANKCASE ASSY.	M2-150
31	C1286160000	1	進氣閥襯墊	GASKET SECOND AIR COVER	
32	C1286060000	1	空氣進氣蓋	COVER,SECOND AIR	M2-125

曲軸箱

E1 CRANK CASE

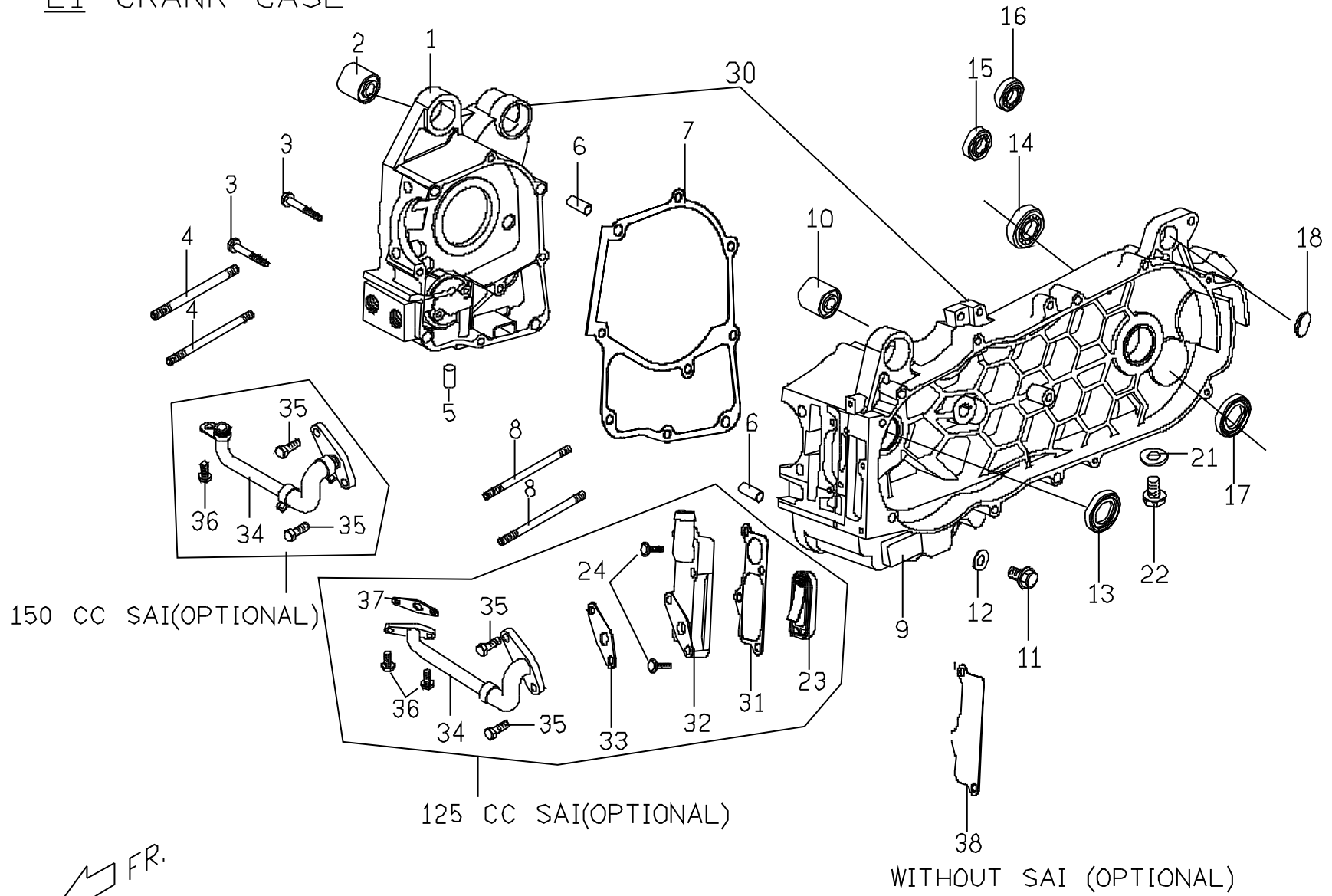

E1 曲軸箱 (CRANKCASE)

AVAILABLE FOR M2-125/150

No. 項目	Part No. 零件號碼	Q'TY 數量	PART NAME 零件中文名稱	PART NAME 零件英文名稱	SPECIFICATION 規格
32	C5286060000	1	空氣進氣蓋	COVER,SECOND AIR	M2-150
33	C1286220000	1	進氣導管襯墊(1)	GASKET,TUBE	
34	C1286201000	1	進氣導管組合	TUBE COMP	M2-125
34	C3286201000	1	進氣導管組合	TUBE COMP	M2-150
35	90190603500	2	六角凸緣螺栓	HEXAGON FLANGE BOLT	
36	90190601601	2	六角凸緣螺栓	HEXAGON FLANGE BOLT	M2-125
36	90190601202	1	六角凸緣螺栓	HEXAGON FLANGE BOLT	M2-150
37	C1286190000	1	進氣導管襯墊(2)	GASKET,TUBE	M2-125
38	C1286320000	1	空氣進氣蓋隔板	SEP PLAT,SECOND AIR COVER	FOR W/O SAI

E2 左邊蓋
LH SIDE COVER

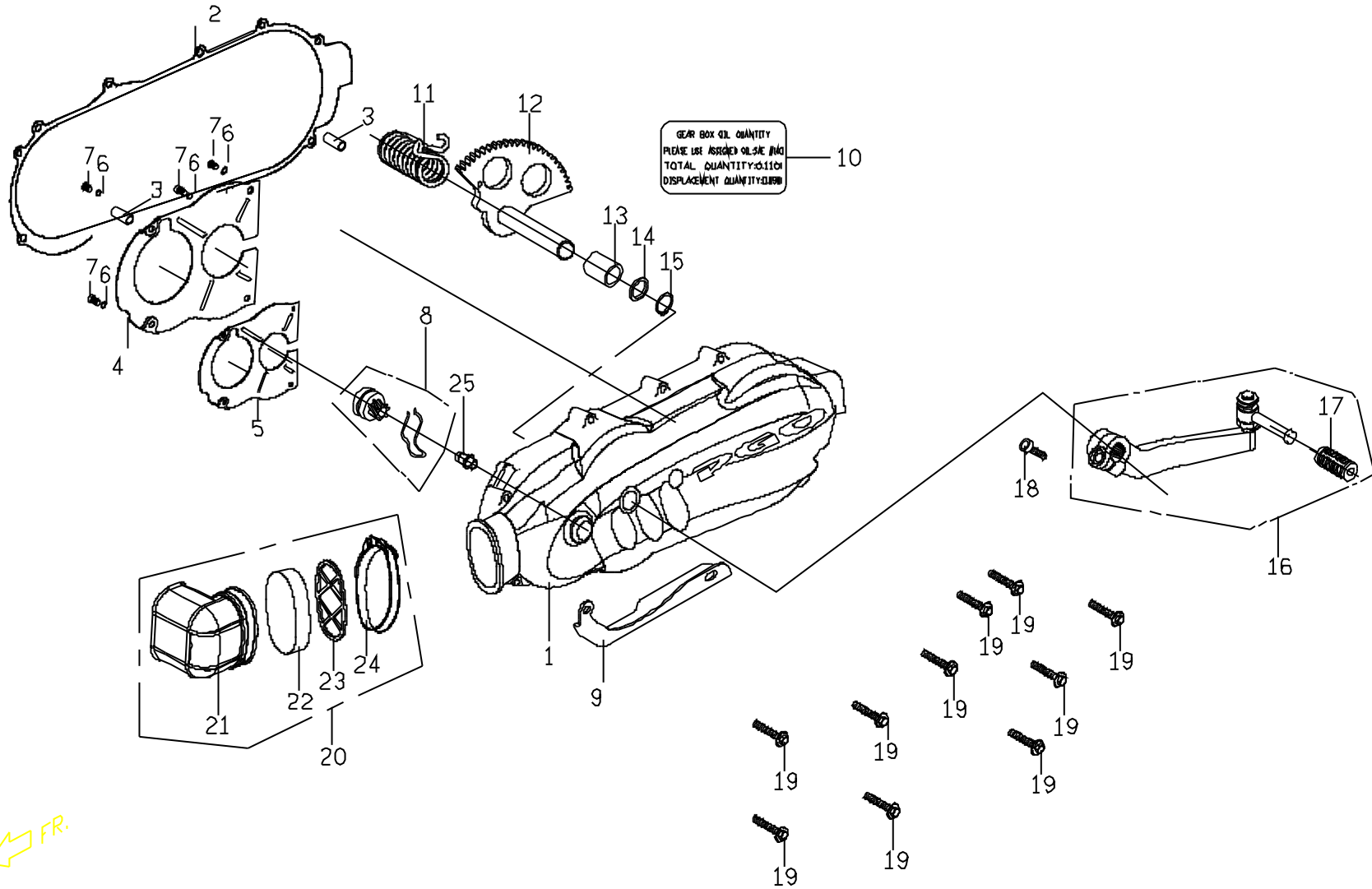

E2 左邊蓋 (LEFT SIDE COVER)

AVAILABLE FOR M2-125/150

No. 項目	Part No. 零件號碼	Q'TY 數量	PART NAME 零件中文名稱	PART NAME 零件英文名稱	SPECIFICATION 規格
1	C1063010720	1	左邊蓋(散銀)	LH SIDE COVER	
2	C1063020000	1	左邊蓋襯墊	GASKET LEFT COVER	
3	93540801400	2	定位銷	LOCK PIN	
4	C10630600001	1	隔板	PARTITION PLATE	
5	C1063120000	1	隔板襯墊	PARTITION PLATE PACKING	
6	92110500000	4	彈簧鎖緊墊圈	SPRING WASHER	
7	90050500900	4	十字圓頭機器螺釘	C-R ROUND HD. TAPPING SCREW	
8	C1251001000	1	腳踏被動齒輪彈簧組合	DRIVEN GEAR & SPG. ASSY.	
9	C1062081000	1	中腳柱止擋托架	BRACKET, CENTER STAND	
10	C1603140000	1	齒輪油注意貼紙(中文)	GEAR OIL NOTICE LABEL(CHINESE)	CHINESE
10	C16031400001	1	齒輪油注意貼紙(英文)	GEAR OIL NOTICE LABEL(ENGLISH)	ENGLISH
11	C1251111000	1	扭轉彈簧	TORSION SPRING	
12	C1251101000	1	腳踏起動心軸組合	KICK,SHAFT ASSY	
13	C1251120000	1	襯套(踏桿)	BUSH,KICK SPINPLE	
14	92141700002	1	平墊圈	PLAIN WASHER	
15	92171700000	1	C型扣環	RETAINING RING C-TYPE	
16	C1251200000	1	起動踏桿組合	ARM,KICK STARTER ASSY	
17	E1251240000	1	起動板膠套	RUBBER,PAD,KICK STARTER	
18	90210802500	1	六角角承窩螺栓	HEXANON SOCKET HEAD CAP BOLT	
19	90190604001	10	六角凸緣螺栓	HEXAGON FLANGE BOLT	
20	M2063100000	1	通風管組合	BREATHER PIPE COMP	
21	M2063030000	1	通風管	BREATHER PIPE	
22	C1063092000	1	過濾棉	SPONGE,BREATHER PIPE	
23	C1063110000	1	固定板	FIXING PLATE	
24	C1706280000	1	管夾	CLAMP	
25	C1251171000	1	起動固定心軸	START FIXED SHAFT	

汽缸頭 (125 CC)

E3.1 CYLINDER HEAD

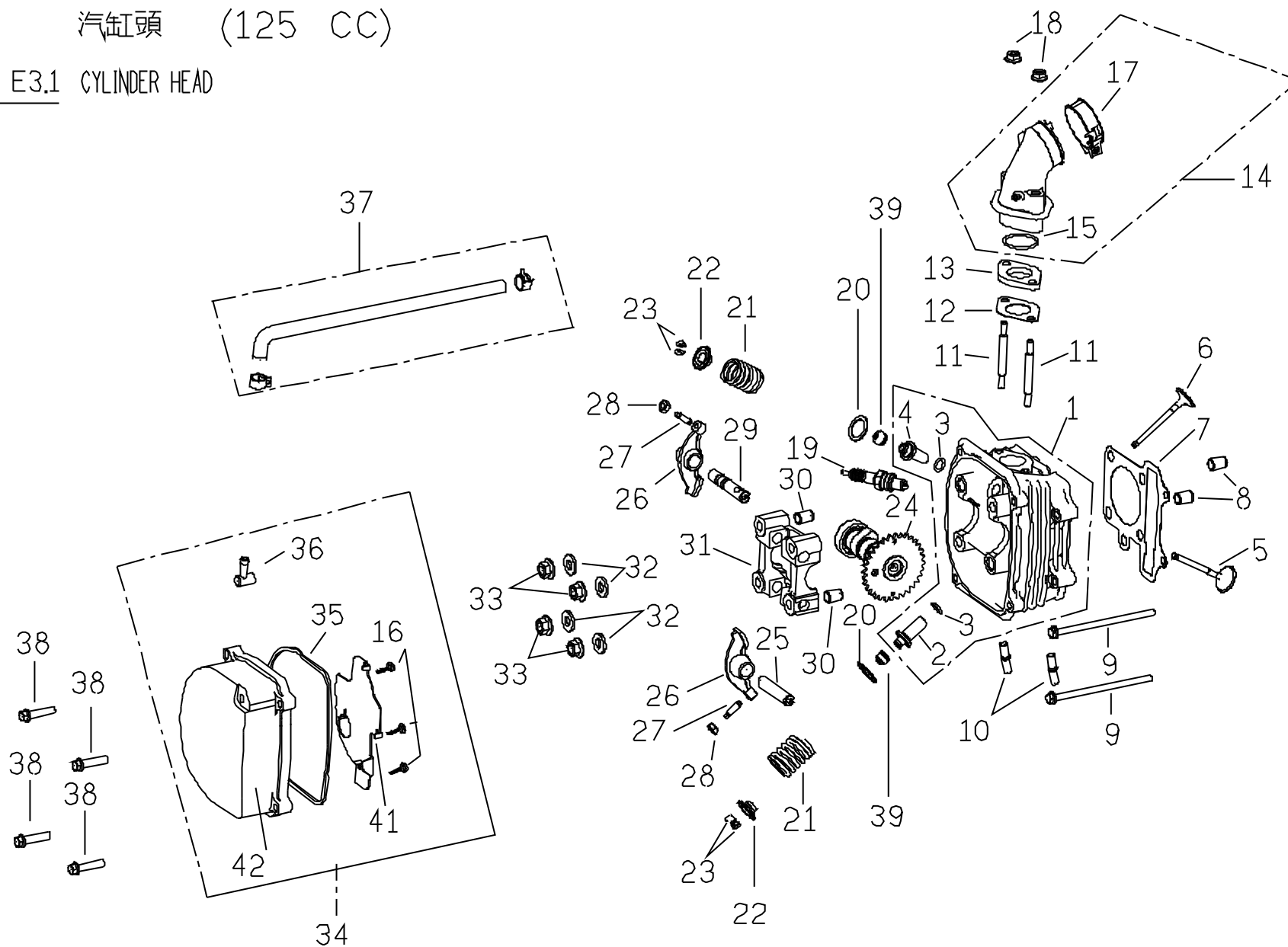

E3.1 汽缸頭，汽缸蓋 (CYLINDER HEAD ASSY.)

Available for M2-125

適用M2-125

No. 項目	Part No. 零件號碼	Q'TY 數量	PART NAME 零件中文名稱	PART NAME 零件英文名稱	SPECIFICATION 規格
1	ACCORDING BOM	1	汽缸頭	HEAD COMP. CYLINDER	OPTIONAL PART
1	C1071012000	1	汽缸頭(有二次空氣)	HEAD COMP. CYLINDER	W/H SAI
1	C10710120001	1	汽缸頭(無二次空氣)	HEAD COMP. CYLINDER	W/O SAI
5	C1071200000	1	排氣閥, (小)	VALVE EXHAUST	
6	C1071300000	1	進氣閥, (大)	VALVE INLET	
7	C1071072000	1	汽缸頭墊片	GASKET HEAD CYL.	
8	93541001401	2	定位銷 (10*14)	LOCK PIN	
9	90190610000	2	六角凸緣螺栓	HEXAGON FLANGE BOLT	
10	90170802900	2	雙頭螺栓	STUD BOLT	
11	90170606300	2	雙頭螺栓	STUD BOLT	
12	C1261320000	1	化油器絕緣板墊片	INSULATOR CARB GASKET	
13	C1261310000	1	化油器絕緣板	INSULATOR CARB	
14	C1261052000	1	進氣歧管組合	INTAKE MANIFOLD COMP	
15	95512700001	1	O形環	O RING	
16	90150400800	4	十字槽扁圓頭自攻螺釘	C-R TAPPING MACHINE SCREW	
17	C1261061000	1	管束	HOSE CLAMP	
18	92040600000	2	六角凸緣螺帽 (M6*1.0P)	HEXAGON FLANGE NUT	
19	C1222000000	1	火星塞(NGK C7HSA)	IGNITION PLUG	
20	92431600002	2	平墊圈	PLAIN WASHER	
21	C1071410000	2	閥門彈簧	SPRING, VALVE	YELLOW
22	C1071440000	2	閥門彈簧承盤	RETAIER VALVE SPRING	
23	C1071430000	4	閥門栓	COTTER VALVE	
24	C1073001000	1	凸輪軸總成	CAM, SHAFT ASSY.	
25	C1072060000	1	排氣閥搖臂軸	SHAFT, EX.ROCKER ARM	
26	C1072010000	2	閥門搖臂, (鳥仔)	VALVE RXKER ARM	
27	C1072420000	2	挺桿調整螺絲	SCREW TOPPED ADJUSTER	
28	92020500001	2	六角螺帽	HEXAGON NUT	
29	C1072050000	1	進氣搖臂軸	SHAFT, EX.ROCKER ARM	
30	93541001401	2	定位銷	LOCK PIN	
31	C1072430000	1	凸輪軸固定座	CAMSHAFT HOLDER	

汽缸頭 (125 CC)

E3.1 CYLINDER HEAD

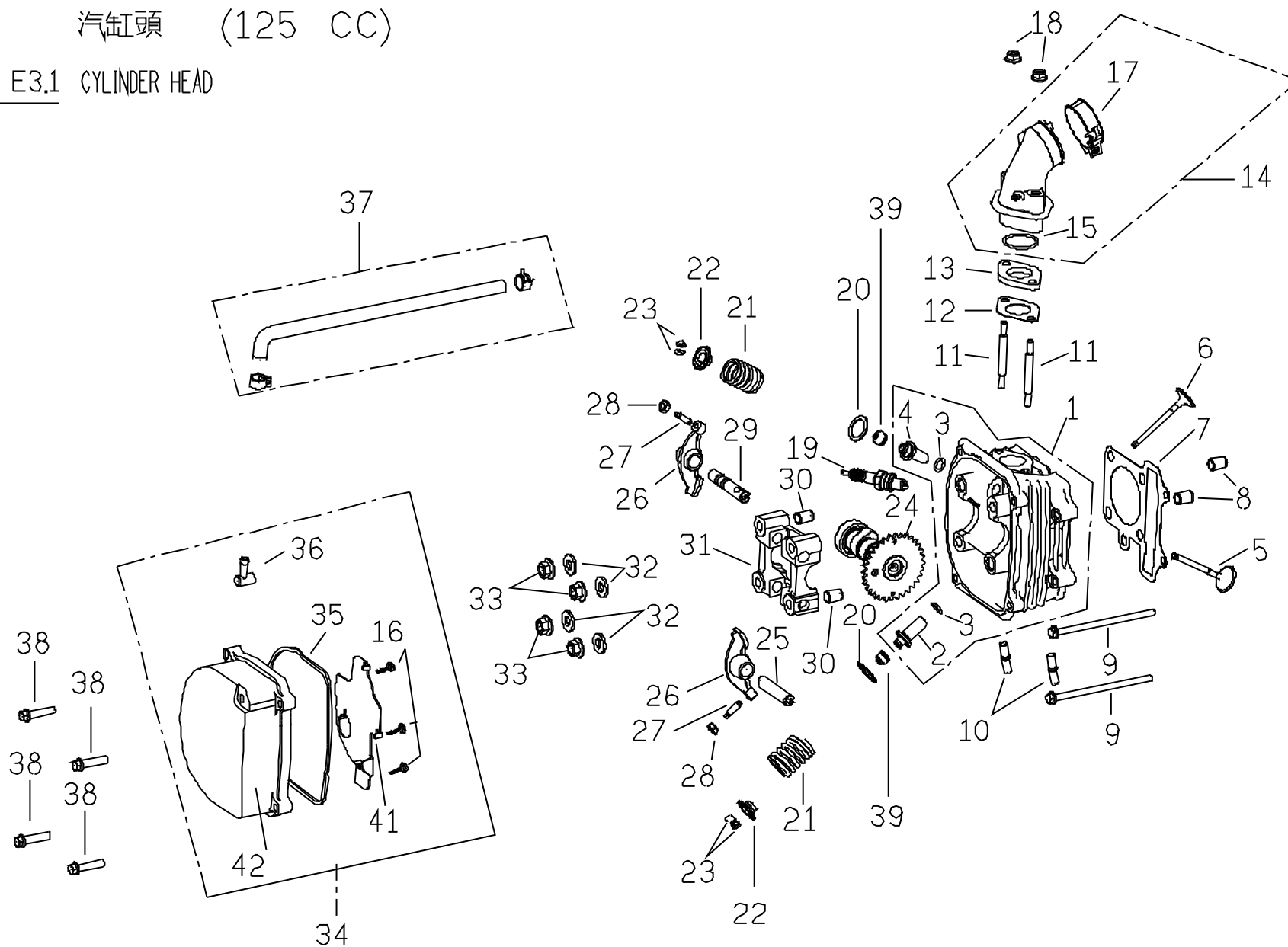

E3.1 汽缸頭，汽缸蓋 (CYLINDER HEAD ASSY.)**Available for M2-125****適用M2-125**

No. 項目	Part No. 零件號碼	Q'TY 數量	PART NAME 零件中文名稱	PART NAME 零件英文名稱	SPECIFICATION 規格
32	92140800000	4	平墊圈 (8.4D*17D*1.6T)	PLAIN WASHER	
33	92040800000	4	六角凸緣螺帽 (M8)	HEXAGON FLANGE NUT	
34	C2071102000	1	汽缸頭蓋組合	CYL.HEAD COVER COMP.	
35	C1071120000	1	汽缸頭蓋襯墊	DACKING,CYL. HEAD COVER	
36	C1071130000	1	通氣管塞	TUBE CYL HEAD COVER	
37	ES071190000	1	通氣管組合	PCV PIPE ASSY	
38	90190602700	4	六角凸緣螺栓	HEXAGON FLANGE BOLT	
39	C1071451000	2	門閥油封	VALVE SEAL	
41	C10711500001	1	隔板	PARTITION Plate	
42	C10711100003	1	汽缸頭蓋	CYLINDER HEAD COVER	

汽缸頭 (150 CC)

E3.2 CYLINDER HEAD . CYLINDER HEAD COVER

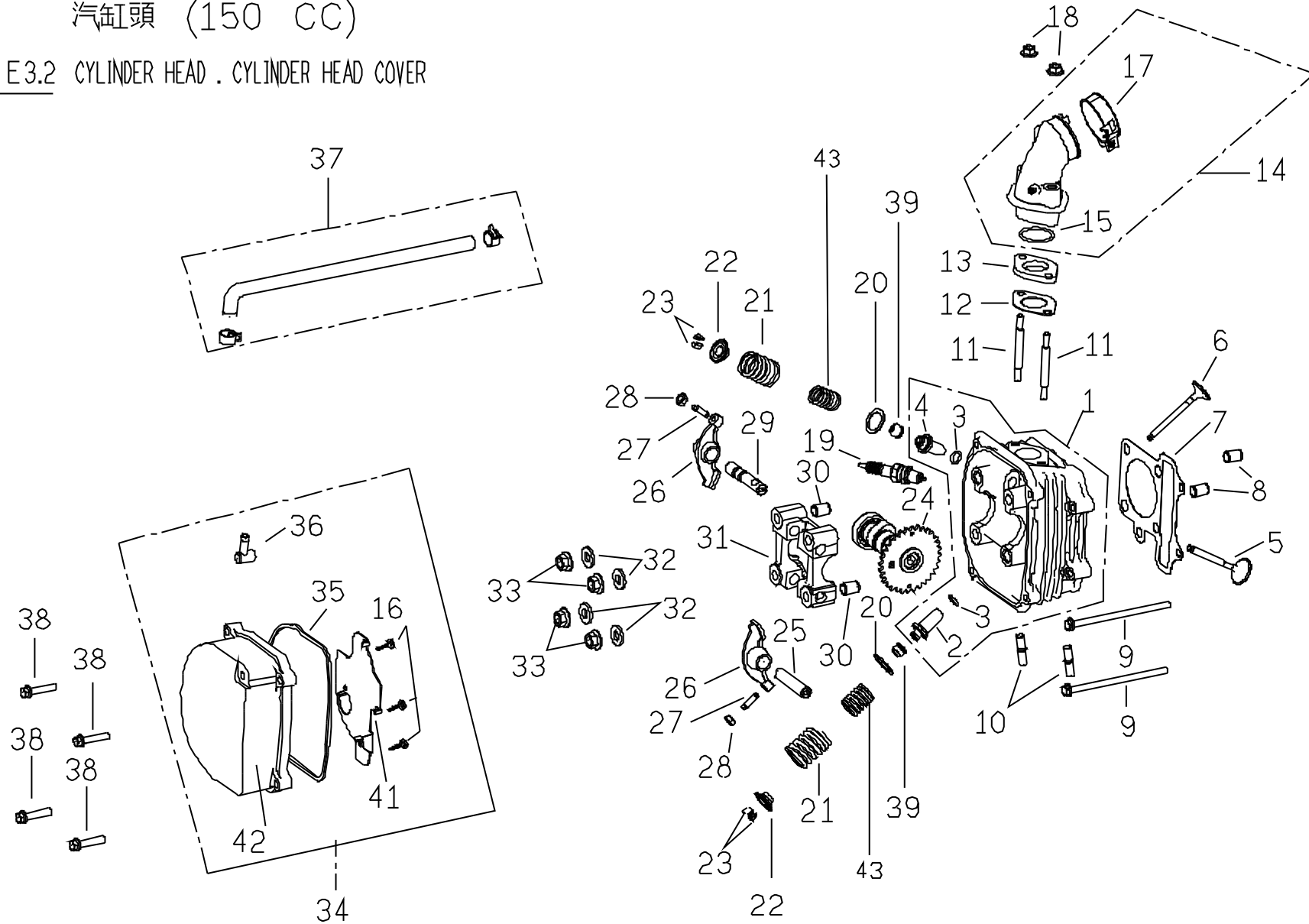

E3.2 汽缸頭，汽缸蓋 (CYLINDER HEAD ASSY.)

Available for M2-150

適用M2-150車型

No. 項目	Part No. 零件號碼	Q'TY 數量	PART NAME 零件中文名稱	PART NAME 零件英文名稱	SPECIFICATION 規格
1	ACCORDING BOM	1	汽缸頭	HEAD COMP. CYLINDER	OPTIONAL PART
1	C50710120001	1	汽缸頭(有二次空氣)	HEAD COMP. CYLINDER	W/H SAI
1	C5071011000	1	汽缸頭(無二次空氣)	HEAD COMP. CYLINDER	W/O SAI
5	C5071200000	1	排氣閥, (小)	VALVE EXHAUST	
6	C5071300000	1	進氣閥, (大)	VALVE INLET	
7	C5071071000	1	汽缸頭墊片	GASKET HEAD CYL.	
8	93541001401	2	定位銷 (10*14)	LOCK PIN	
9	90190610000	2	六角凸緣螺栓	HEXAGON FLANGE BOLT	
10	90170802900	2	雙頭螺栓	STUD BOLT	
11	90170606300	2	雙頭螺栓	STUD BOLT	
12	C1261320000	1	化油器絕緣板墊片	INSULATOR CARB GASKET	
13	C1261310000	1	化油器絕緣板	INSULATOR CARB	
14	C1261052000	1	進氣歧管組合	INTAKE MANIFOLD COMP	
15	95512700001	1	O形環	O RING	
16	90150400800	4	十字槽扁圓頭自攻螺釘	C-R TAPPING MACHINE SCREW	
17	C1261061000	1	管束	HOSE CLAMP	
18	92040600000	2	六角凸緣螺帽 (M6*1.0P)	HEXAGON FLANGE NUT	
19	C1222000000	1	火星塞(NGK C7HSA)	IGNITION PLUG	
20	92431600002	2	平墊圈	PLAIN WASHER	
21	C5071411000	2	閥門外彈簧	SPRING, VALVE	RED
22	C1071440000	2	閥門彈簧承盤	RETAIER VALVE SPRING	
23	C1071430000	4	閥門栓	COTTER VALVE	
24	C5073000000	1	凸輪軸總成	CAM,SHAFT ASSY.	M2-150
25	C1072060000	1	排氣閥搖臂軸	SHAFT,EX.ROCKER ARM	
26	C1072010000	2	閥門搖臂, (鳥仔)	VALVE RXKER ARM	
27	C1072420000	2	挺桿調整螺絲	SCREW TOPPED ADJUSTER	
28	92020500001	2	六角螺帽	HEXAGON NUT	
29	C1072050000	1	進氣搖臂軸	SHAFT,EX.ROCKER ARM	
30	93541001401	2	定位銷	LOCK PIN	
31	C1072430000	1	凸輪軸固定座	CAMSHAFT HOLDER	

汽缸頭 (150 CC)

E3.2 CYLINDER HEAD . CYLINDER HEAD COVER

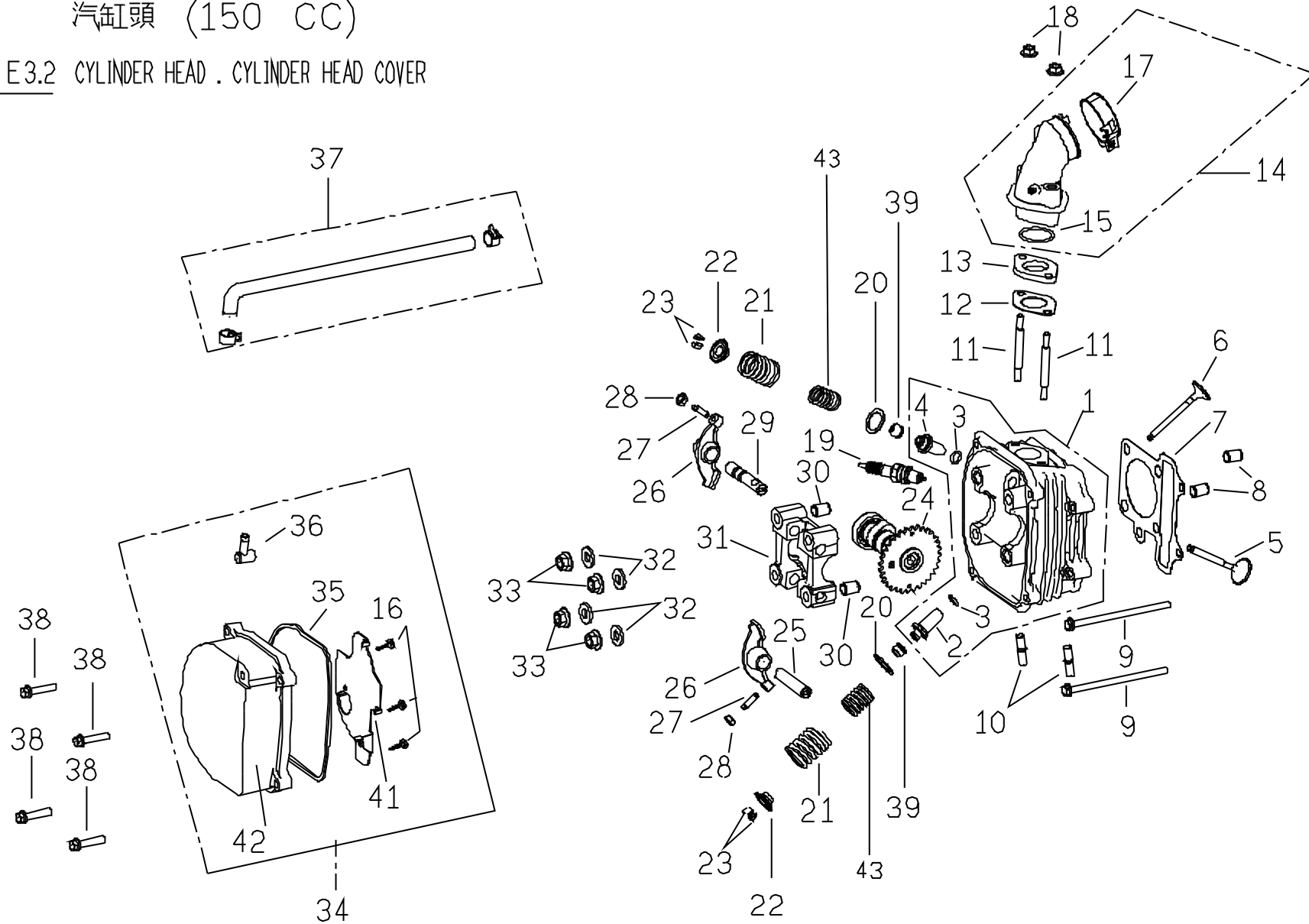

E3.2 汽缸頭，汽缸蓋 (CYLINDER HEAD ASSY.)**Available for M2-150****適用M2-150車型**

No. 項目	Part No. 零件號碼	Q'TY 數量	PART NAME 零件中文名稱	PART NAME 零件英文名稱	SPECIFICATION 規格
32	92140800000	4	平墊圈 (8.4D*17D*1.6T)	PLAIN WASHER	
33	92040800000	4	六角凸緣螺帽 (M8)	HEXAGON FLANGE NUT	
34	C2071102000	1	汽缸頭蓋組合	CYL.HEAD COVER COMP.	
35	C1071120000	1	汽缸頭蓋襯墊	DACKING,CYL. HEAD COVER	
36	C1071130000	1	通氣管塞	TUBE CYL HEAD COVER	
37	ES071190000	1	通氣管組合	PCV PIPE ASSY	
38	90190602700	4	六角凸緣螺栓	HEXAGON FLANGE BOLT	
39	C1071451000	2	門閥油封	VALVE SEAL	
41	C10711500001	1	隔板	PARTITION Plate	
42	C10711100003	1	汽缸頭蓋	CYLINDER HEAD COVER	CP/CS化油器車型
43	C5071421000	2	閥門內彈簧	SPRING,VALVE	紅色

曲軸及汽缸 (125 CC)

E4.1 CYLINDER . PISTON . CRANKSHAFT

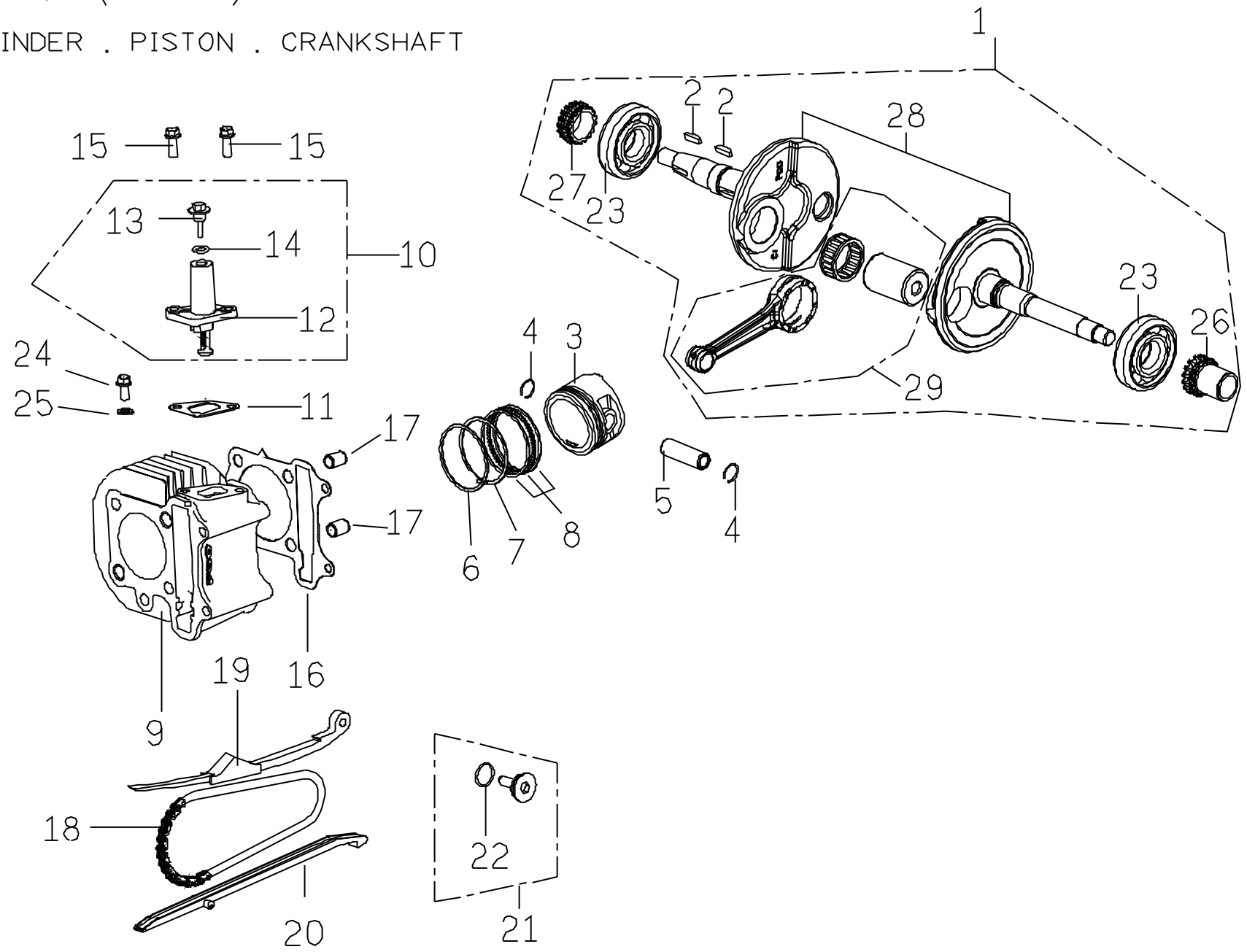

E4.1 汽缸，活塞，曲柄軸總成 (CYLINDER, CRANKSHAFT)**Available for M2-125****適用M2-125**

No. 項目	Part No. 零件號碼	Q'TY 數量	PART NAME 零件中文名稱	PART NAME 零件英文名稱	SPECIFICATION 規格
1	M20665000001	1	曲柄軸總成	CRANKSHAFT COMP.	M2-125
2	93530402500	2	半月鍵	WOODRUFF KEY	
3	C1067013000	1	活塞	PISTON	
4	C1067150000	2	活塞銷夾	CLIP,PISTON PIN	
5	C1067110000	1	活塞銷	PISTON PIN	
6	C10673100001	1	活塞環(1)"R1"	PISTON RING (1)	
7	C1067321000	1	活塞環(2)"RN"	PISTON RING (2)	
8	C1067402000	1	刮油環組合	OIL SCRAPER RING COMP	
9	C1064011000	1	汽缸	CYLINDER	
10	C1072500000	1	鏈條調整器組合	CHAIN ADJUSTER COMP.	
11	C1072480000	1	鏈條調整器墊片	GASKET,CHAIN ADJUSTER	
13	C1072560000	1	鍊條調整器螺栓	CHAIN ADJUSTER BOLT	
14	95510900001	1	O形環	O RING	
15	90190601601	1	六角凸緣螺栓	HEXAGON FLANGE BOLT	
16	C1064110000	1	汽缸墊片	GASKET CYLINDER	
17	93541001401	2	定位銷 (10*14)	LOCK PIN	
18	C1072460000	1	凸輪軸鏈條	CHAIN,CAMSHAFT	
19	C1072440000	1	鏈條拉力桿	TENSIONER,CAM CHAIN	
20	C1072470000	1	鏈條導件	GUIDE COMP,CAM CHAIN	
21	C1072490000	1	拉力桿螺絲組合	PIVOT,CAM CHAIN TENSION	
22	95511500001	1	O型環	O RING	
23	C1062100000	2	滾珠軸承 (特殊)	ROLLER BEARING	
24	90190601200	1	六角凸緣螺栓 (M6*1.0P*12L)	HEXAGON FLANGE BOLT	
25	92140600011	1	平墊圈	PLAIN WASHER	
26	C1066130000	1	正時鍊輪	TIMING SPROCKET	
27	C1066140000	1	機油泵鍊輪	OIL PUMP SPROCKET	
28	M206F010000	1	左右曲軸組合	LH & RH CRANKSHAFT ASSY.	
29	C106F020000	1	連桿組合	CONNECTING ROD ASSY.	

曲軸及汽缸 (150 CC)

E4.2 CYLINDER . PISTON , CRANKSHAFT

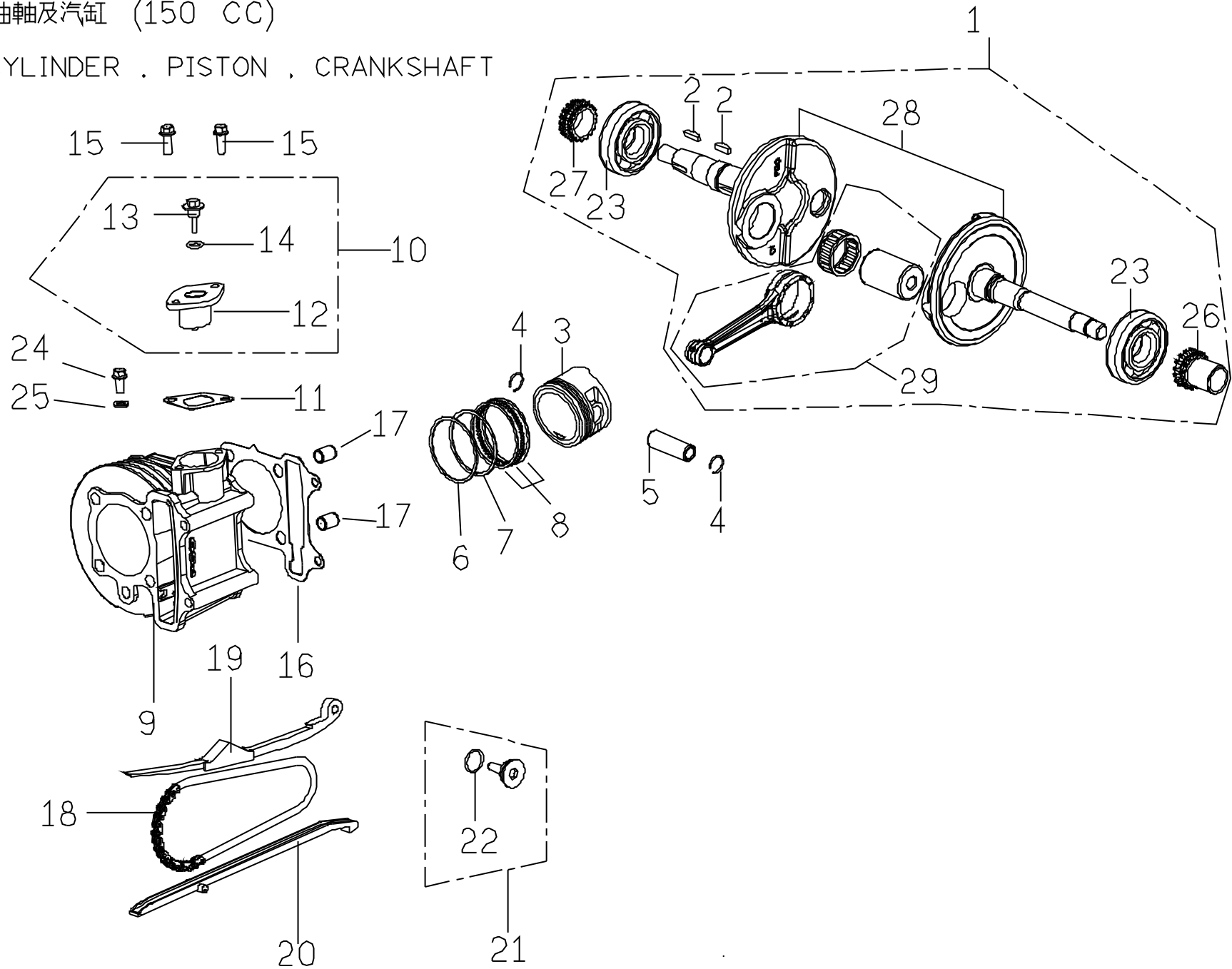

E4.2汽缸，活塞，曲柄軸總成 (CYLINDER, CRANKSHAFT)

Available for M2-150 (150.1cc)

適用M2-150車型

No. 項目	Part No. 零件號碼	Q'TY 數量	PART NAME 零件中文名稱	PART NAME 零件英文名稱	SPECIFICATION 規格
1	M2066501000	1	曲柄軸總成	CRANKSHAFT COMP.	M2-150
2	93530402500	2	半月鍵	WOODRUFF KEY	
3	C5067012000	1	活塞	PISTON	
4	G1067151000	2	活塞銷夾	CLIP,PISTON PIN	
5	C5067110000	1	活塞銷	PISTON PIN	
6	C5067310000	1	活塞環(1)"R1"	PISTON RING (1)	
7	C5067320000	1	活塞環(2)"RN"	PISTON RING (2)	
8	C5067400000	1	刮油環組合	OIL SCRAPER RING COMP	
9	C50640100004	1	汽缸(57.5 mm)	CYLINDER	57.5mm
10	C5072500000	1	鏈條調整器組合	CHAIN ADJUSTER COMP.	
11	C5072480000	1	鏈條調整器墊片	GASKET,CHAIN ADJUSTER	
13	C1072560000	1	鍊條調整器螺栓	CHAIN ADJUSTER BOLT	
14	95510900001	1	O形環	O RING	
15	90190601601	1	六角凸緣螺栓	HEXAGON FLANGE BOLT	
16	C5064110000	1	汽缸墊片	GASKET CYLINDER	
17	93541001401	2	定位銷 (10*14)	LOCK PIN	
18	C1072460000	1	凸輪軸鏈條	CHAIN,CAMSHAFT	
19	C1072440000	1	鏈條拉力桿	TENSIONER,CAM CHAIN	
20	C5072470000	1	鏈條導件	GUIDE COMP,CAM CHAIN	
21	C1072490000	1	拉力桿螺絲組合	PIVOT,CAM CHAIN TENSION	
22	95511500001	1	O型環	O RING	
23	C1062100000	2	滾珠軸承 (特殊)	ROLLER BEARING	
24	90190601200	1	六角凸緣螺栓 (M6*1.0P*12L)	HEXAGON FLANGE BOLT	
25	92140600011	1	平墊圈	PLAIN WASHER	
26	C5066130000	1	正時鍊輪	TIMING SPROCKET	
27	C1066140000	1	機油泵鍊輪	OIL PUMP SPROCKET	
28	M206F010000	1	左右曲軸組合	LH & RH CRANKSHAFT ASSY.	
29	C506F1100002	1	連桿組合	CONNECTING ROD ASSY.	

E5 右曲軸箱蓋

RIGHT CRANKCASE COVER

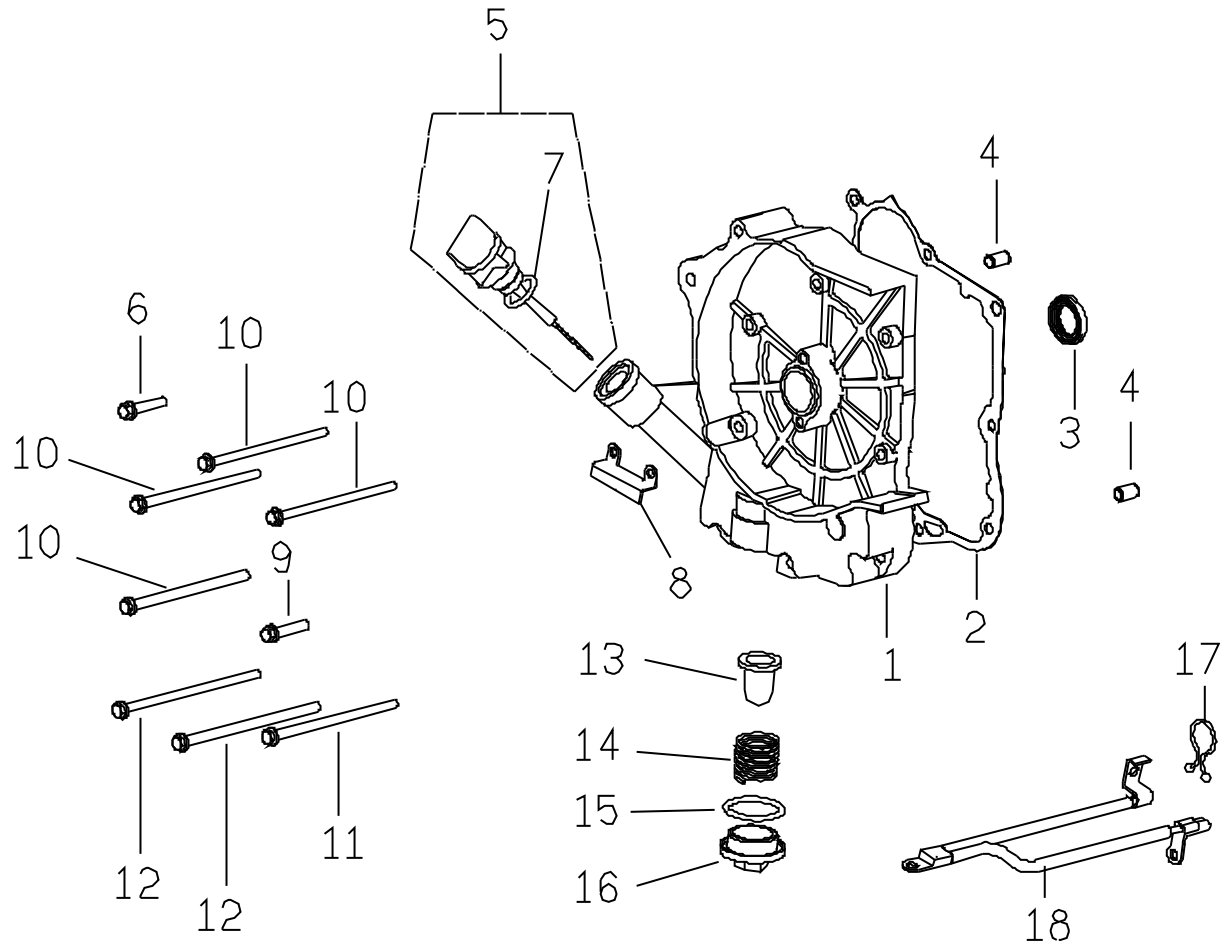

E5.右曲軸箱蓋 (STARTING MOTOR)

AVAILABLE FOR M2-125/150

No. 項目	Part No. 零件號碼	Q'TY 數量	PART NAME 零件中文名稱	PART NAME 零件英文名稱	SPECIFICATION 規格
1	C10680100002	1	右曲軸箱蓋	RH. CRANKCASE COVER	
2	C1068020000	1	右曲軸箱蓋墊片	GASKET RH. CRANKCASE COVER	
3	95572030501	1	TC形油封(φ30*φ18*5t)	OIL SEAL TC TYPE	FOR RH CASE COVER
4	93540801400	2	定位銷	LOCK PIN	
5	C2068110000	1	機油尺組合	GAUSE,OIL LEVEL COMP	
6	90190603000	1	六角凸緣螺栓 (M6*30L)	HEXAGON FLANGE BOLT	
7	95511800001	1	O形環	O-RING	
8	C1706640000	1	A.C.G壓板	A.C.G PLATE	
9	90190602700	1	六角凸緣螺栓 (M6*27L)	HEXAGON FLANGE BOLT	
10	90190609500	4	六角凸緣螺栓	HEXAGON FLANGE BOLT	
11	90190610000	1	六角凸緣螺栓	HEXAGON FLANGE BOLT	
12	90190611000	2	六角凸緣螺栓	HEXAGON FLANGE BOLT	
13	G1062180000	1	濾油網	SCREEN OIL FILTER	
14	C1062190000	1	壓縮彈簧	SPRING OIL FILTER SCREEN	
15	95513100000	1	O形環	O-RING	
16	C1062240000	1	濾油網蓋	CAP TAPPET ADJUSTING HOLE	
17	C1701270000	1	塑膠鎖扣	PURSE LOCK	
18	C1241030000	1	起動馬達接地線	START MOTOR, LINE	

E6. 化油器
CARBURETOR

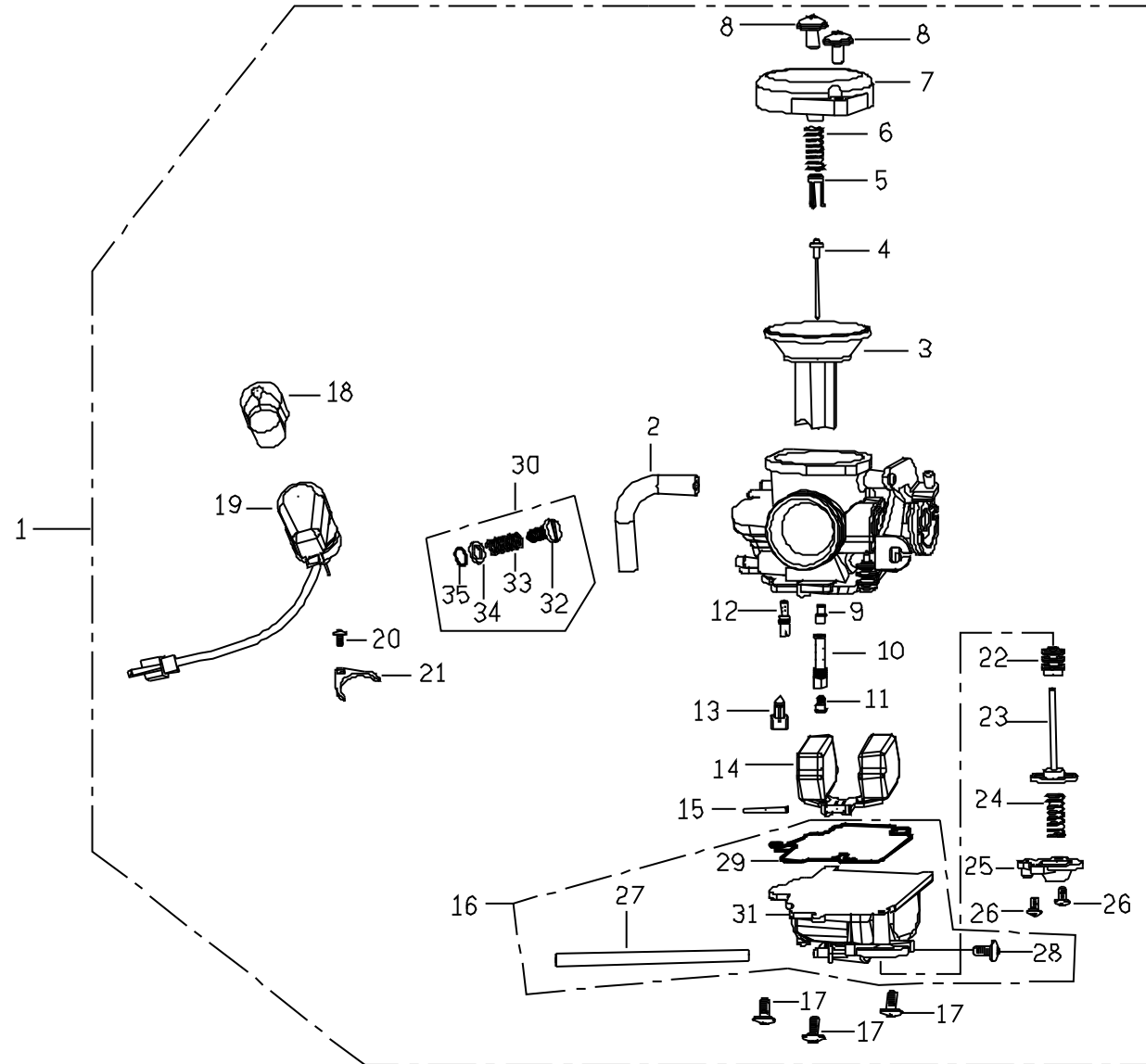

E6.1 化油器,有EEC/ (CARBURETOR,WITH EEC SYSTEM)

Available for with EEC regulation

No. 項目	Part No. 零件號碼	Q'TY 數量	PART NAME 零件中文名稱	PART NAME 零件英文名稱	SPECIFICATION 規格
1	C1151000002	1	化油器總成 (SETTING 112)	CARBURETOR ASSY (SETTING 112)	M2-125
1	C5151000002	1	化油器總成 (SETTING 114)	CARBURETOR ASSY (SETTING 114)	M2-150
2	16199GY69000	1	橡膠管	TUBE SET	
3	14029122101	1	真空活塞組	VACUUM PISTON COMP	
4	N4255DGHN	1	油針	JET NEEDLE COMP	
5	12298057000	1	閥板	VALVE PLATE SET	
6	1290A232000	1	壓縮彈簧	SPG;COMPR	
7	10308737003	1	上蓋	TOP SET	
8	01108031100	2	螺絲組	SCREW,PAN	
9	N42636430	1	油針噴嘴	NEEDLE JET	M2-125
9	N42636330	1	油針噴嘴	NEEDLE JET	M2-150
10	N41318C00	1	油針噴嘴套管	NEEDLE JET HOLDER	
11	991011161020	1	主噴嘴(#102)	MAIN JET	
12	1001440H0351	1	低速噴嘴(#35)	SLOW JET	
13	16155ZG8L100	1	浮動閥組	FLOAT VALVE SET	
14	10528622101	1	浮筒組	FLOAT COMP	
15	W952525250	1	浮筒銷	ARM PIN	
16	K3500840100	1	油室組總成	FLOAT CHAMBER SET	
17	93500040121H	3	螺絲組	SCREW,PAN	
18	12308567001	1	保溫蓋	HOLDER CAP	
19	40000940000	1	自動旁通起動組	AUTO BYSTARTER SET	
20	938920400818	1	墊片螺絲	SCREW WASHER	
21	10908732001	1	固定片	SET PLATE	
22	10280547000	1	封閉蓋	SEALING CAP	
23	12018302201	1	膜片組	DIAPHRAGM COMP	
24	1290A072000	1	壓縮彈簧	SPG;COMPR	
25	12308502000	1	蓋	COVER	
26	93500040101H	2	螺絲	SCREW;PAN	
27	1785402H0040	1	橡膠管	TUBE SET	

E6. 化油器
CARBURETOR

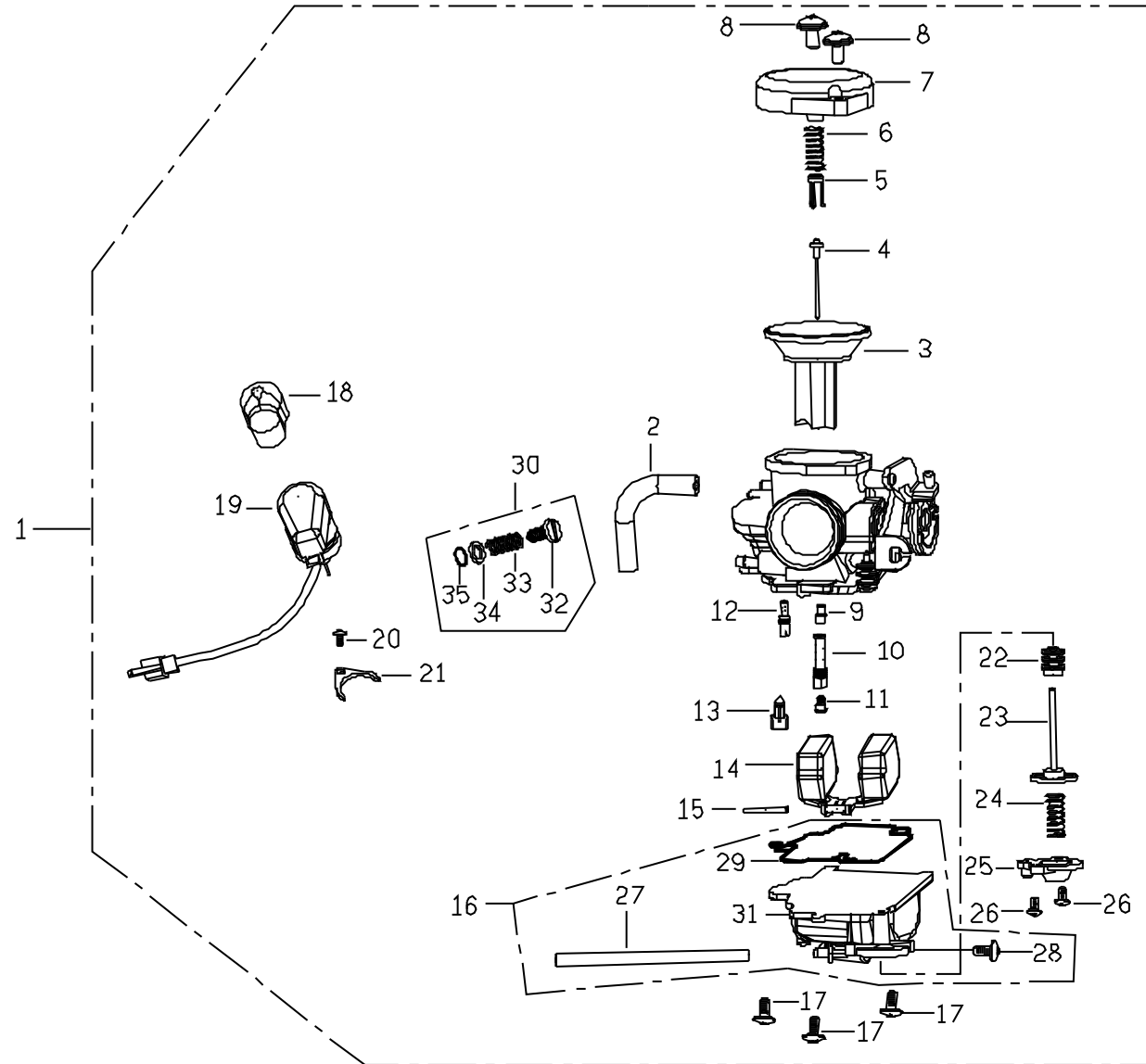

E6.1 化油器,有EEC/ (CARBURETOR,WITH EEC SYSTEM)**Available for with EEC regulation**

No. 項目	Part No. 零件號碼	Q'TY 數量	PART NAME 零件中文名稱	PART NAME 零件英文名稱	SPECIFICATION 規格
28	11988222000	1	卸油螺絲	DRAIN SCREW	
29	12028656000	1	墊片	O RING	
30	K4460100100	1	油量調整螺絲組合	PILOT SCREW SET	
31	N35062E00	1	油室組	FLOAT CHAMBER	
32	N44612B00	1	螺絲	SCREW	
33	W17115189901	1	壓縮彈簧	COMPRESION SPRING	
34	03018032000	1	平墊圈	PLAIN WASHER	
35	16075KG89010M1	1	O形環	O RING	

E7 自動變速系統

CVT TRANSMISSION

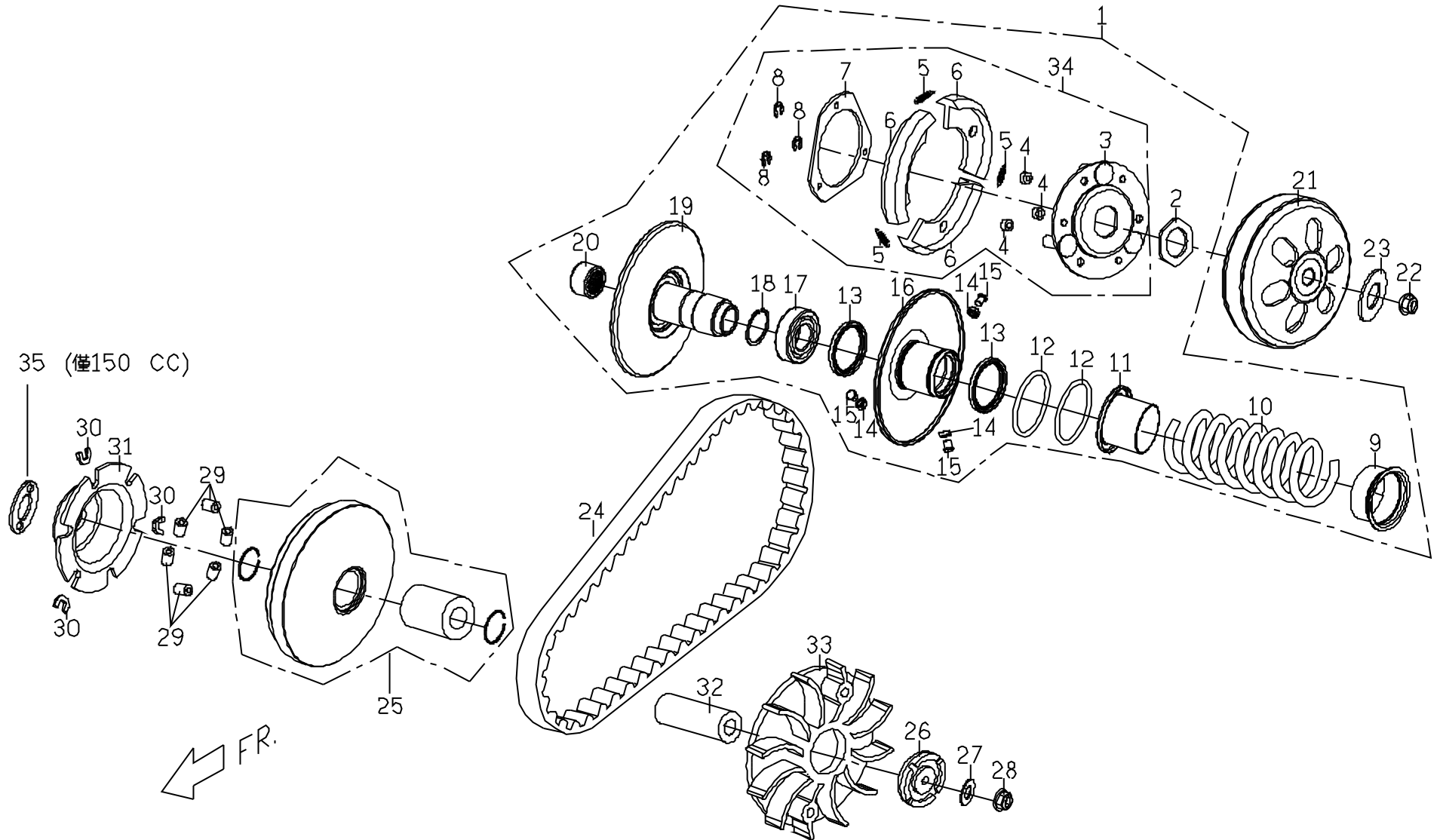

E7. 傳動皮帶輪 (DRIVING PULLEY)

AVAILABLE FOR M2-125/150

No. 項目	Part No. 零件號碼	Q'TY 數量	PART NAME 零件中文名稱	PART NAME 零件英文名稱	SPECIFICATION 規格
1	C1123700000	1	被驅動面皮帶輪組合	BELT PULLEY COMP,DRIVEN FACE	M2-125
1	C5123700000	1	被驅動面皮帶輪組合	BELT PULLEY COMP,DRIVEN FACE	M2-150
2	P1123410000	1	特殊螺帽	NUT	
3	C1123300000	1	驅動板本體組合	BODY COMP,DRIVE PLATE	
4	C1123420000	3	離合器阻尼橡膠	DAMPER RUBBER,CLUTCH	
5	C1123430000	3	離合器彈簧	SPRING,CLUTCH	
6	C1123440000	3	離合器比重組	WEIGHT SET,CLUTCH	
7	C1123450000	1	離合器壓板	PRESSURE PLATE,CLUTCH	
8	92180700000	3	E型扣環	RETAINING RING E TYPE	
9	C1123330000	1	彈簧套筒	COLLAR,SPRING	
10	C1123520000	1	被驅動面彈簧	SPG,DRIVEN FACE	M2-125
10	C5123520000	1	被驅動面彈簧	SPG,DRIVEN FACE	M2-150
11	C1123530000	1	密封套筒	SEALED SOCKET	
12	95514000001	2	O形環	O-RING	
13	95593441400	2	G型油封	OIL SEAL G TYPE	
14	C1123250000	3	襯套	BUSH	
15	C1123240000	3	導滾銷	PIN,GRIDE	
16	C1123210000	1	活動被驅動面本體組合	BODY COMP,DRIVEN FACE	
17	96520690200	1	單封深槽滾珠軸承	DEEP GROOVE BALL BEAR ONE SEAL	
18	92162800000	1	C型扣環	RETAINING RING C TYPE	
19	C1123110000	1	被驅動面本體組合	DOBY COMP,DRIVEN FACE	
20	96550202900	1	滾針軸承	NEEDLE BEARING	
21	C1123510000	1	離合器外套本體組合	OUTER BODY COMP,CLUTCH	
22	92041200002	1	六角凸緣螺帽	HEXAGON FLANGE NUT	
23	92141200005	1	平墊圈	PLAIN WASHER	
24	C11220000001	1	皮帶 (V型)	V BELT	
25	C11211000001	1	活動驅動面組合	FACE MOVABLE DRIVE	
26	C1251030000	1	起動棘輪	RATCHET KICK STARTER	
27	92141200005	1	平墊圈	PLAIN WASHER	
28	92041200002	1	六角凸緣螺帽	HEXAGON FLANGE NUT	

E7 自動變速系統

CVT TRANSMISSION

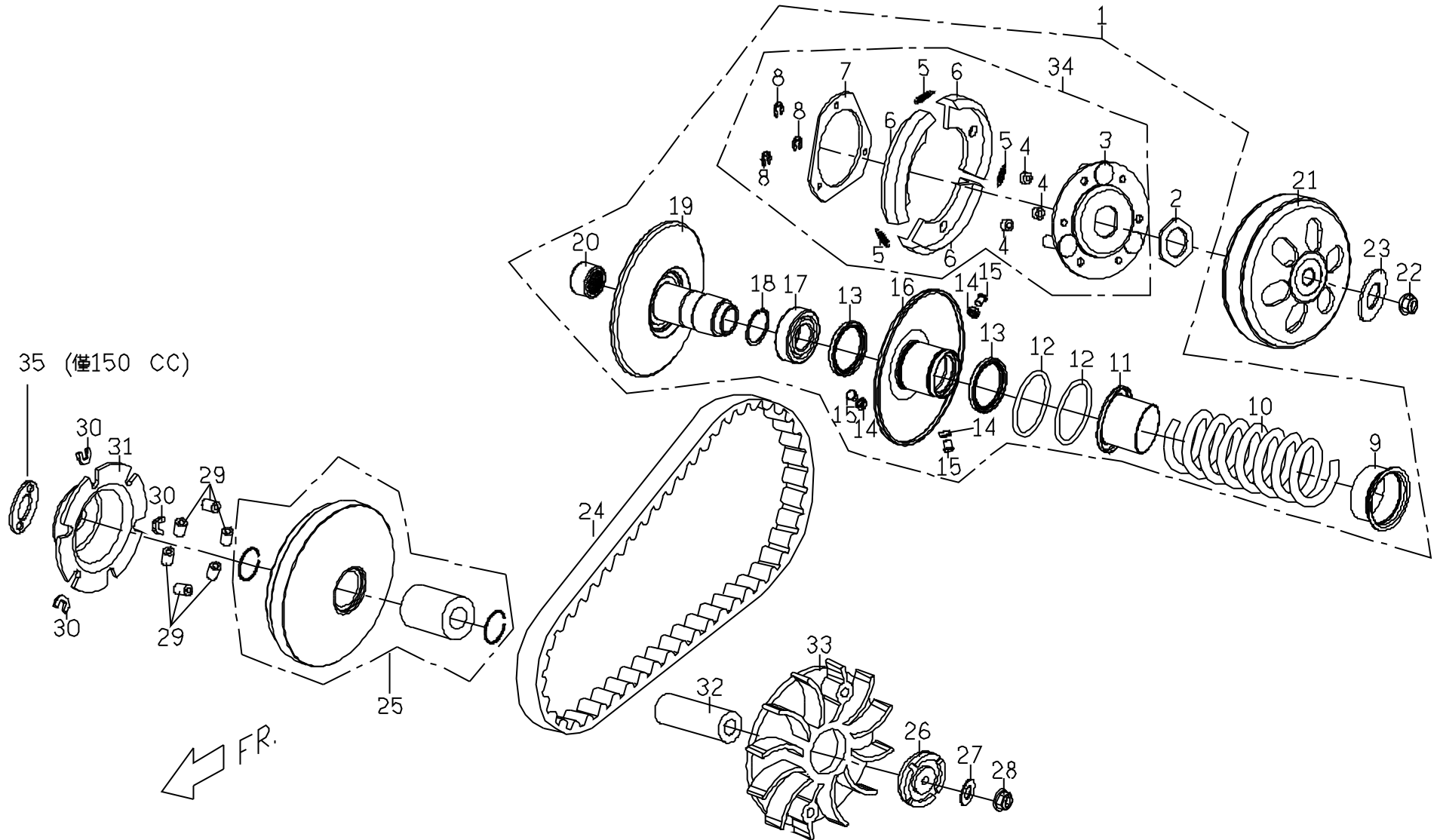

E7. 傳動皮帶輪 (DRIVING PULLEY)

AVAILABLE FOR M2-125/150

No. 項目	Part No. 零件號碼	Q'TY 數量	PART NAME 零件中文名稱	PART NAME 零件英文名稱	SPECIFICATION 規格
29	C1121200001	6	配重滾子組合, 11g	WEIGHT ROLLER COMP.	M2-125
29	C1121200000	6	配重滾子組合, 13g	WEIGHT ROLLER COMP.	M2-150
30	C1121321000	3	滑塊	SIDE PIECE	
31	C1121310000	1	斜坡板	RAMP PLATE	
32	C1121050000	1	活動驅動面輪殼	BOSS,MOVABLE DRIVE FACE	
33	C11210600001	1	驅動面	DRIVE FACE	
34	C1123600000	1	驅動板組合	DRIVEN PULLEY ASSY.	
35	C5066051000	1	間隔套環	DRIVEN PULLEY ASSY.	M2-150 ONLY

E8 發電機 / 風扇罩
 FAN COVER, GENERATOR

ENGINE OIL QUANTITY
 PLEASE USE ASSIGNED OIL SAE 15W40
 TOTAL QUANTITY 0.80L
 DISPLACEMENT QUANTITY 0.80L
 IF OIL DISPLACEMENT PLEASE USE IN LEVEL GAUGE
 TO CHECK IF IT IS FULL OF OIL
 CHECK OIL LEVEL IN POSITION OFF POSITION
 EVERY 3 MINUTES OF RUNNING

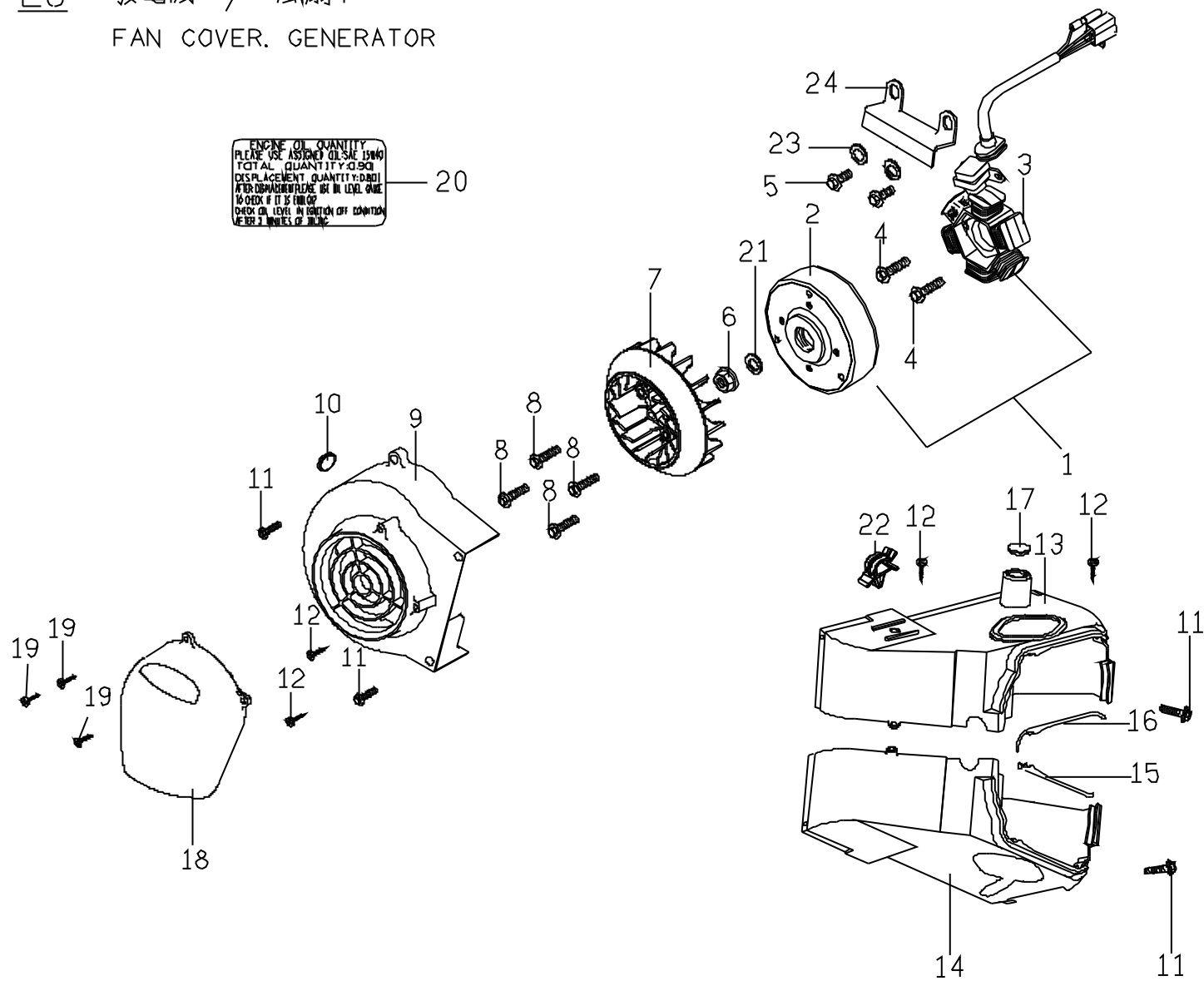

E8 風扇蓋，發電機 (GENERATOR)

AVAILABLE FOR M2-125/150

No. 項目	Part No. 零件號碼	Q'TY 數量	PART NAME 零件中文名稱	PART NAME 零件英文名稱	SPECIFICATION 規格
1	C2221000000	1	飛輪磁電機總成(單向直流)	DC GENERATOR ASSY	M2-125
1	C5221000001	1	飛輪磁電機總成(單向直流)	DC GENERATOR ASSY	M2-150
2	C2221010000	1	飛輪	FLYWHEEL COMP	M2-125
2	C5221010001	1	飛輪	FLYWHEEL COMP	M2-150
3	C2221020000	1	固定轉子	STATOR COMP	
4	90180602000	2	六角凸緣螺栓(M6*20L)	HEXAGON FLANGE BOLT	
5	90190501201	2	六角凸緣螺栓(M5*12L)	HEXAGON FLANGE BOLT	
6	92041200000	1	六角凸緣螺帽	HEXAGON FLANGE NUT	
7	C1043001000	1	風扇	FAN	
8	90190601204	4	六角凸緣螺栓	HEXAGON FLANGE BOLT	
9	C1042001000	1	風扇罩	FAN COVER	
10	C1042030000	1	橡膠塞	RUBBER PLUG	
11	90180602000	4	六角凸緣螺栓(M6*20L)	HEXAGON FLANGE BOLT	
12	90130501400	4	十字槽盤頭自攻螺釘(M5*16L)	CR PAN HD.TAPPING SCREW	
13	C1042213000	1	冷卻罩(2)	COOLING COWL(2)	M2-125
13	C5042210000	1	冷卻罩(2)	COOLING COWL(2)	M2-150
14	C1042102000	1	冷卻罩(1)	COOLING COWL(1)	M2-125
14	C5042102000	1	冷卻罩(1)	COOLING COWL(1)	M2-150
15	C1042120000	1	冷卻罩油封(1)	SEAL,COOLING HOOD(1)	
16	C1042220000	1	冷卻罩油封(2)	SEAL,COOLING HOOD(2)	
17	C1701260000	1	橡膠塞	RUBBER PLUG	
18	C1042242000	1	風扇罩蓋	FAN COVER'S COVER	
19	90110401600	3	十字槽盤頭自攻螺釘(M5*16L)	CR PAN HD.TAPPING SCREW	
20	C1603130000	1	引擎機油注意貼紙(中文)	OIL NOTICE LABEL (CHINESE)	
20	C16031300001	1	引擎機油注意貼紙(英文)	OIL NOTICE LABEL (ENGLISH)	
21	92141200005	1	平墊圈	PLAIN WASHER	
22	C1701290000	1	塑膠鎖扣	PLASTIC LOCKER	
23	92110500000	2	平墊圈	PLAIN WASHER	
24	C1706640000	1	ACG壓板	ACG PLATE	

E9

起動馬達

STARTING MOTOR, OIL PUMP

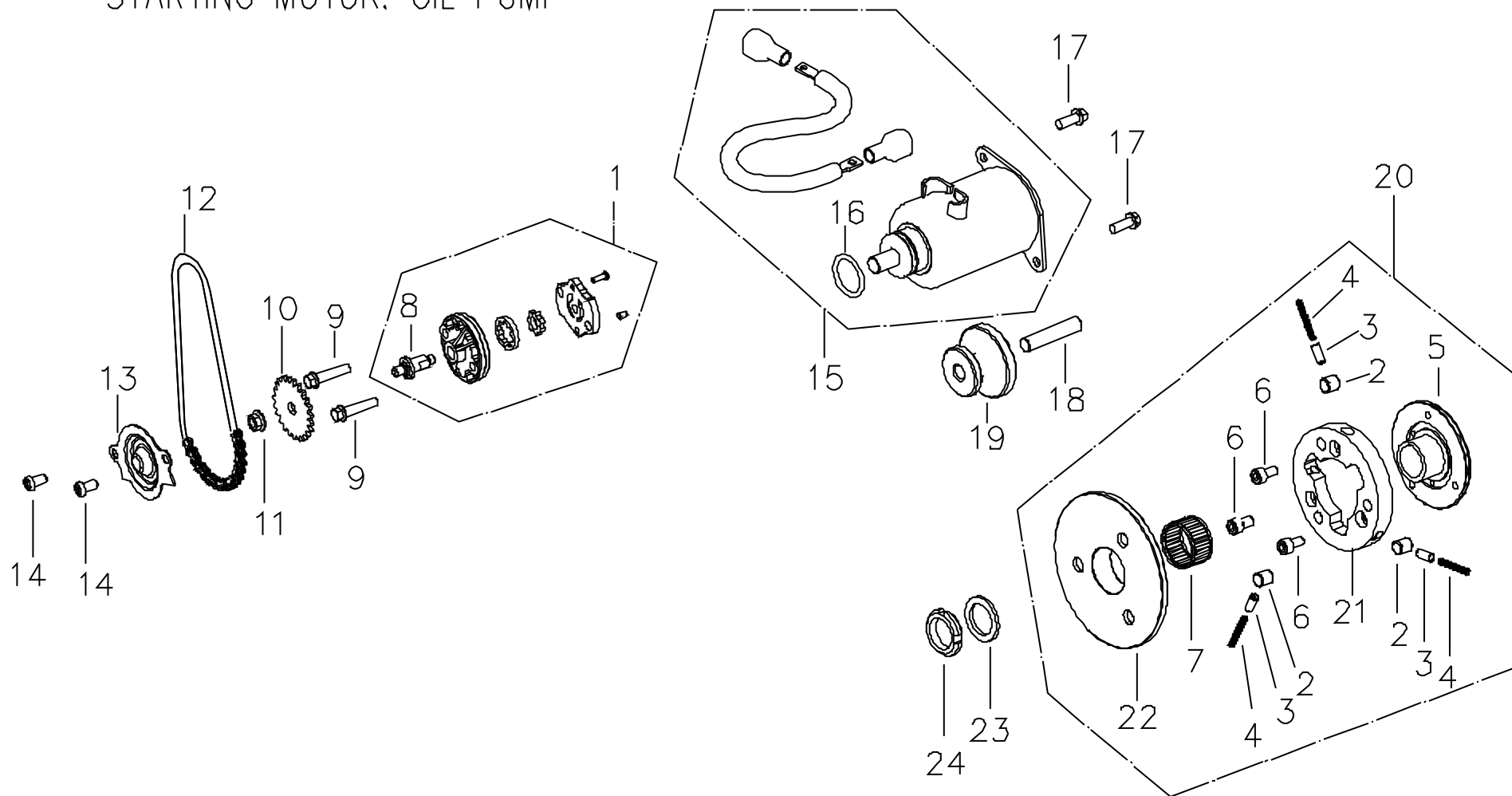

E9 . GMAX GENERATOR

AVAILABLE FOR M2-125/150

No.	Part No.	Q'TY	PART NAME	PART NAME	REMARK
項目	零件號碼	數量	零件中文名稱	零件英文名稱	備註
1	C1081000000	1	機油泵總成	OIL PUMP ASSY	
2	C1243030000	3	單向離合器滾柱	ROLLER ONE WAY CLUTCH	
3	C1243020000	3	套筒	COP,ROLLER SPRING	
4	G1243010000	3	壓縮彈簧	COMPRESS SPRING	
5	C12430500001	1	起動離合器凸緣	COVER CLUTCH OUTER	
6	90210801000	3	六角承窩螺栓	INNER HEX BOLT	
7	96590283200	1	滾針軸承	NEEDLE BEARING	
8	C1081070000	1	機油泵軸	SHAFT,OIL PUMP	
9	90190602700	2	六角凸緣螺栓 (M6*27L)	HEXAGON FLANGE BOLT	
10	C1081030000	1	機油泵驅動齒輪	SPRKT OIL PUMP DRIVEN	
11	92040600000	1	六角凸緣螺帽 (M6*1.0P)	HEXAGON FLANGE BOLT	
12	C1081220000	1	機油泵驅動鏈條	CHAIN,OIL PUMP	
13	C1081230000	1	機油分隔板	SEPARATER OIL	
14	E1681030000	2	盤頭帶墊圈螺栓	WITH WASHER HEX BOLT	
15	C1241000000	1	起動馬達組合	START MOOT COMP.	
16	95512400002	1	O形環	O RING	
17	90190601601	2	六角凸緣螺栓	HEXAGON FLANGE BOLT	
18	C1242040000	1	起動減速齒輪軸	SHAFT,STARTET REDUCTION GEAR	
19	C1242010000	1	起動減速齒輪	GEAR,STARTER REOUCTION	
20	C12430000001	1	單向離合器總成	ONE WAY CLUTCH ASSY.	
21	NA	1	單向離合器組合	ONE WAY CLUTCH COMP.	
22	C1244000000	1	起動離合器齒輪組合	GEAR COMP.STARTING CLUTCH	
23	92142200000	1	平墊圈	PLAIN WASHER	
24	C1243060000	1	鎖定螺帽	NUT LOCK	

E10 傳動齒輪箱

GEAR TRANSMISSION

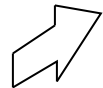
FR. 

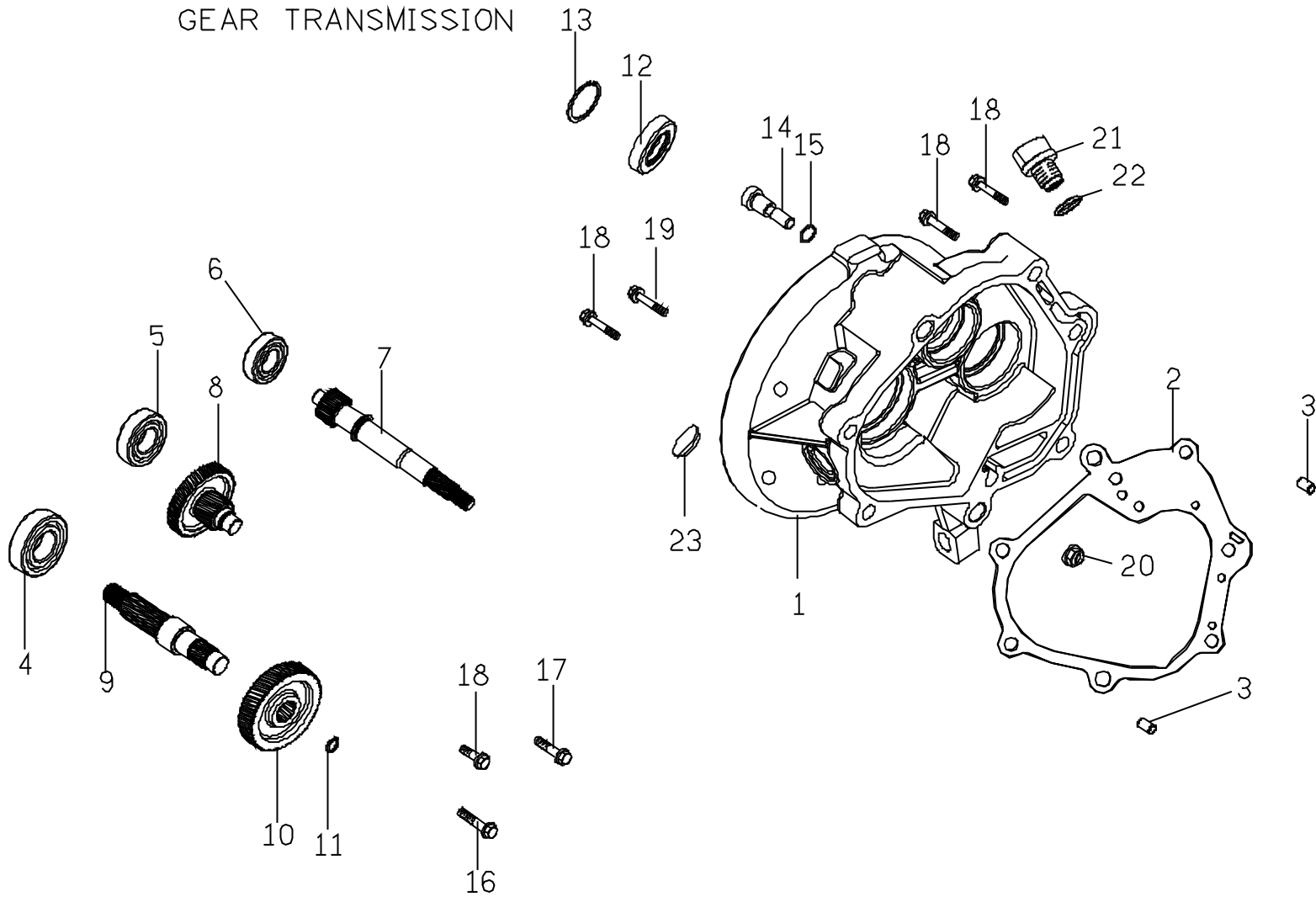

E10. GMAX GEARBOX

AVAILABLE FOR M2-125/150

No.	Part No.	Q'TY	PART NAME	PART NAME	REMARK
項目	零件號碼	數量	零件中文名稱	零件英文名稱	備註
1	C2141011000	1	傳動箱蓋	TRANSMISSION COVER	
2	C2141020000	1	傳動箱蓋襯墊	TRANSMISSION COVER GASKET	
3	93541001401	2	定位銷(10*14)	LOCK PIN	
4	96510630100	1	深槽滾珠軸承(6301)	BALL BEARING	
5	96510600200	1	深槽滾珠軸承(6002)	BALL BEARING	
6	96530622200	1	雙封滾珠軸承(6222)	BALL BEARING.DOUBLE SEALED	
7	C11411000003	1	驅動軸	DRIVE SHAFT	M2-125
7	C3141100000	1	驅動軸	DRIVE SHAFT	M2-150
8	C11412000003	1	惰齒輪組合	IDLE GEAR COMP.	M2-125
8	C31412000001	1	惰齒輪組合	IDLE GEAR COMP.	M2-150
9	C11414110001	1	後軸	AXLE DRIVE	
10	C11413100003	1	最終齒輪	FINAL GEAR	M2-125
10	C11413100003	1	最終齒輪	FINAL GEAR	M2-150
11	92172000000	1	C型扣環	RETAINING RING C TYPE	
12	95572742700	1	TC形油封(φ42*φ25.8*7t)	OIL SEAL TC TYPE	
13	92165000000	1	C型扣環(孔用)	RETAINING RING C TYPE	
14	M2407430000	1	煞車軸蹄樞軸	PIVOT REAR BK.SHDE	
15	95510800000	1	O形環(7.5*1.5)	O RING	
16	90190805001	1	六角凸緣螺栓(M8*50L)	HEXAGON FLANGE BOLT	
17	90190804501	1	六角凸緣螺栓(M8*45L)	HEXAGON FLANGE BOLT	
18	90190804003	4	六角凸緣螺栓(M8*40L)	HEXAGON FLANGE BOLT	
19	90190802600	1	六角凸緣螺栓(M8*26L)	HEXAGON FLANGE BOLT	
20	92060800000	1	六角凸緣螺帽(M8*1.25P)	HEXAGON FLANGE NUT	
21	P1062150000	1	機油螺栓	OIL BOLT	
22	95511300001	1	O形環	O-RING	
23	M2701070000	1	塑膠塞	RUBBER PLUG	

E11.1 空氣濾清器組合(有EEC)
AIR CLEANER COMP,
W/H EEC SYSTEM

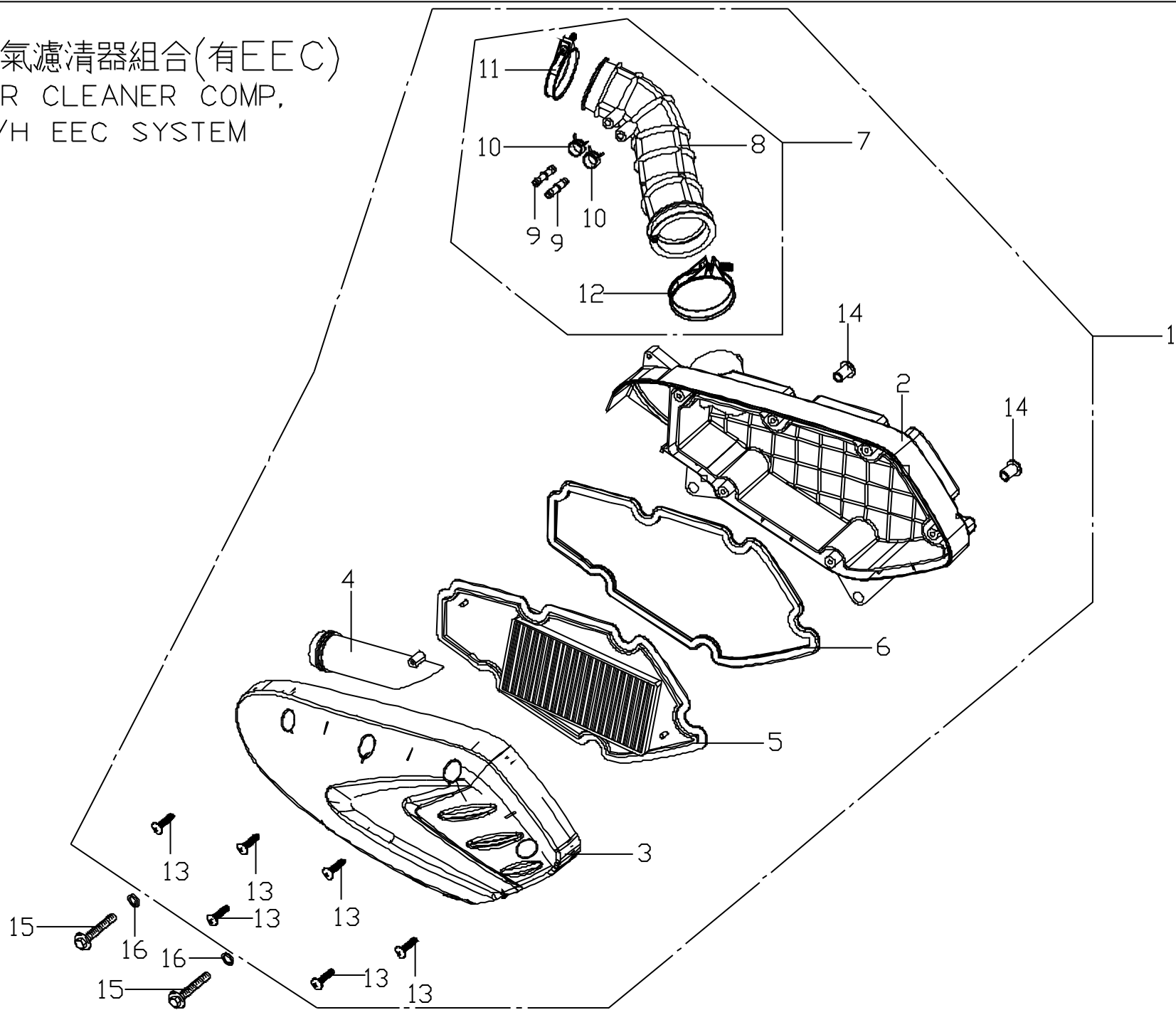

E11.1 AIR CLEANER COMP., / 空氣濾清器組合,有EEC

Available for with EEC regulation

No.	Part No.	Q'TY	PART NAME	PART NAME	REMARK
項目	零件號碼	數量	零件中文名稱	零件英文名稱	備註
1	M2262001000	1	空濾清器組合	AIR CLEAN ASSEMBLY	M2-125
1	M22620010002	1	空濾清器組合	AIR CLEAN ASSEMBLY	M2-150
2	NA	1	空濾器本體	AIR CLEANER BODY	
3	M2262020000	1	空濾器外蓋	AIR CLEANER COVER	
4	M2262060000	1	入口導管	INDUCT PIPE	
5	M2262030000	1	空濾器紙蕊	ELEMENT, AIR CLEANER	
6	M2262040000	1	紙蕊墊圈	PACKING	
8	M22620500001	1	出口導管	OUTLET PIPE	M2-125
8	M2262050000	1	出口導管	OUTLET PIPE	M2-150
9	M2262360000	2	二通接管	2 WAY CONNECTOR	
10	92221000001	2	板管夾	PLAIN CLIP	
11	M2262110000	1	夾緊環	CLIP	
12	M2262380000	1	夾緊環	CLIP	
13	90150502500	6	鎖緊螺絲	TAPPING SCREW	
14	NE262060000	2	襯套	BUSH	
15	90190603000	2	六角凸緣螺栓(M6*45L)	HEXAGON FLANGE BOLT	
16	92140600005	2	平墊圈	PLAIN WASHER	

E12

消音器
MUFFLER

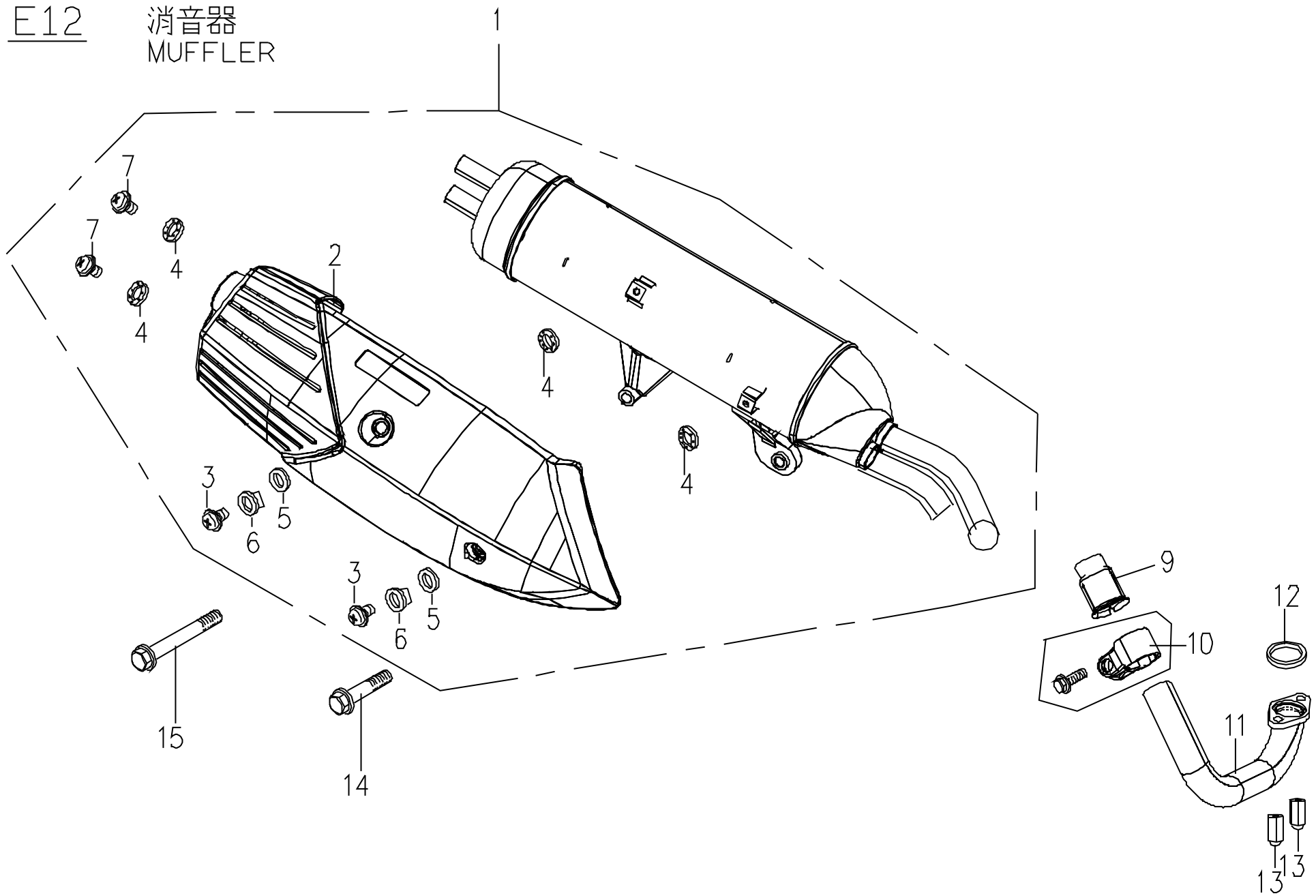

E13 後輪 REAR WHEEL

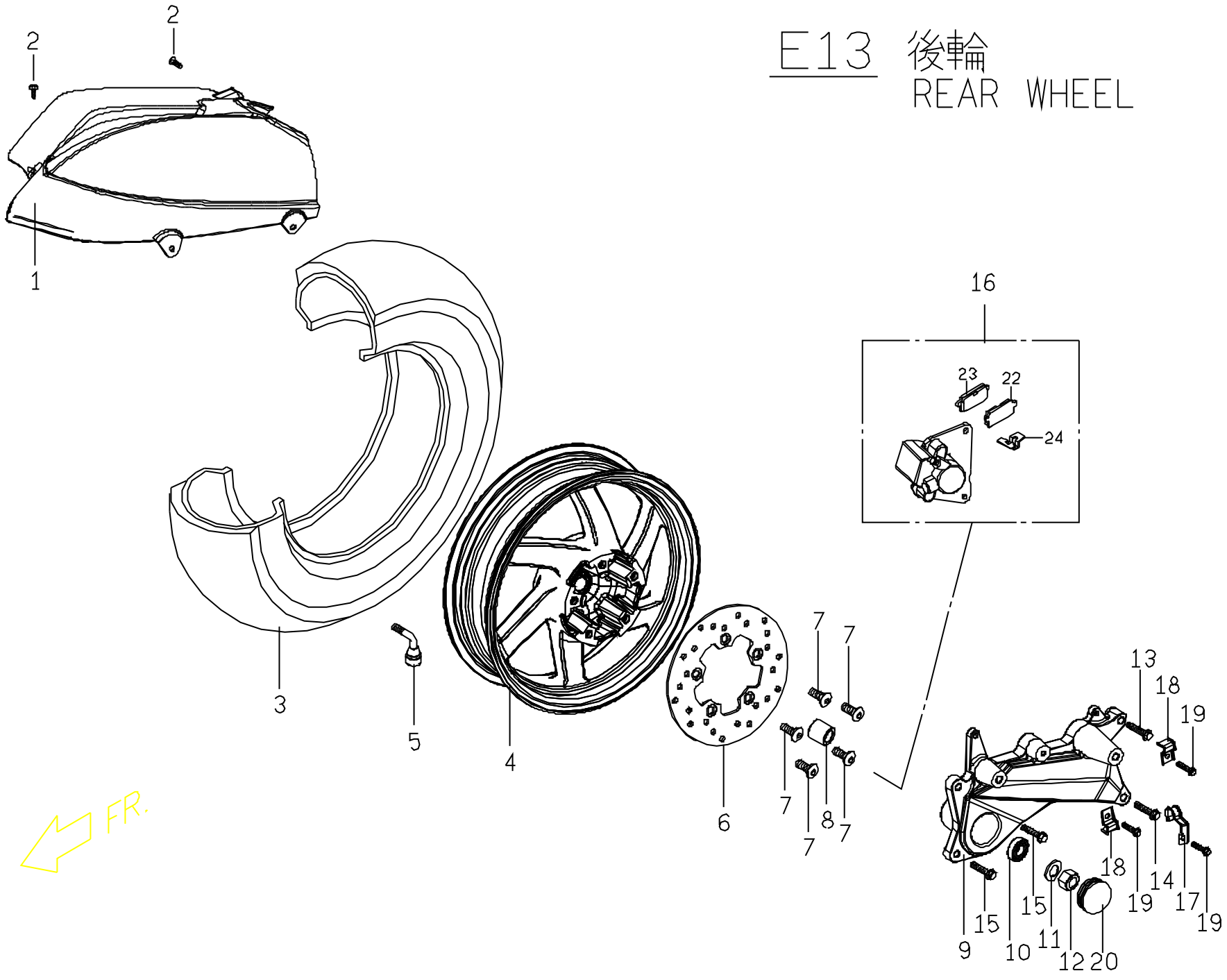

E13.引擎 / 後輪 / ENGINE REAR WHEEL

AVAILABLE FOR M2-125/150

No.	Part No.	Q'TY	PART NAME	PART NAME	REMARK
項目	零件號碼	數量	零件中文名稱	零件英文名稱	備註
1	M2634000650	1	後土除(超黑)	REAR FENDER	
2	90130501400	2	十字槽盤頭自攻螺釘	CR PAN HD.TAPPING SCREW	
3	M240G320000	1	後輪胎總成130/60-13	REAR TIRE	
4	M2406101770	1	後輪圈(13")	REAR WHEEL RIM	
5	P140B330000	1	氣門嘴	VALVE	
6	M2406800000	1	後煞車碟盤(M2原型)	REAR BRAKE DISK	
7	C1403510000	5	前煞車盤螺絲(M8*1.25P*24L)	SCREW, FR BRAKE DISK(M8*1.25P*24L)	
8	M2406840000	1	襯套	BUSH	
9	M2406830000	1	後叉	REAR ENGINE BRACKET	
10	96530600300	1	雙封深槽滾珠軸承	BALL BEARING, DOUBLE SEALED	
11	92141700001	1	平墊圈	WASHER	
12	92011600000	1	U型螺帽	U TYPE SPRING NUT	
13	90190804501	1	六角凸緣螺栓	HEXAGON FLANGE BOLT	
14	90190804501	1	六角凸緣螺栓	HEXAGON FLANGE BOLT	
15	90190802300	2	六角凸緣螺栓	HEXAGON FLANGE BOLT	
16	M2406600000	1	後煞車夾	REAR BRAKE CALIPER	
17	M2403720000	1	煞車油管夾(B)	BRAKE TUBE CLAMP (B)	
18	M2403710000	2	煞車油管夾(A)	BRAKE TUBE CLAMP (A)	
19	90190602002	3	六角凸緣螺栓(M6*20L)	HEXAGON FLANGE BOLT	
20	M2701050000	1	塑膠塞(φ48內塞)	RUBBER PLUG	
22	M240C430000	1	內煞車片組成	INNER PAD	
23	M240C440000	1	外煞車片組成	OUTTER PAD	
24	X040C420000	1	軛簧	YOKE	

機油冷卻器

E14. OIL COOLER & LH COVER

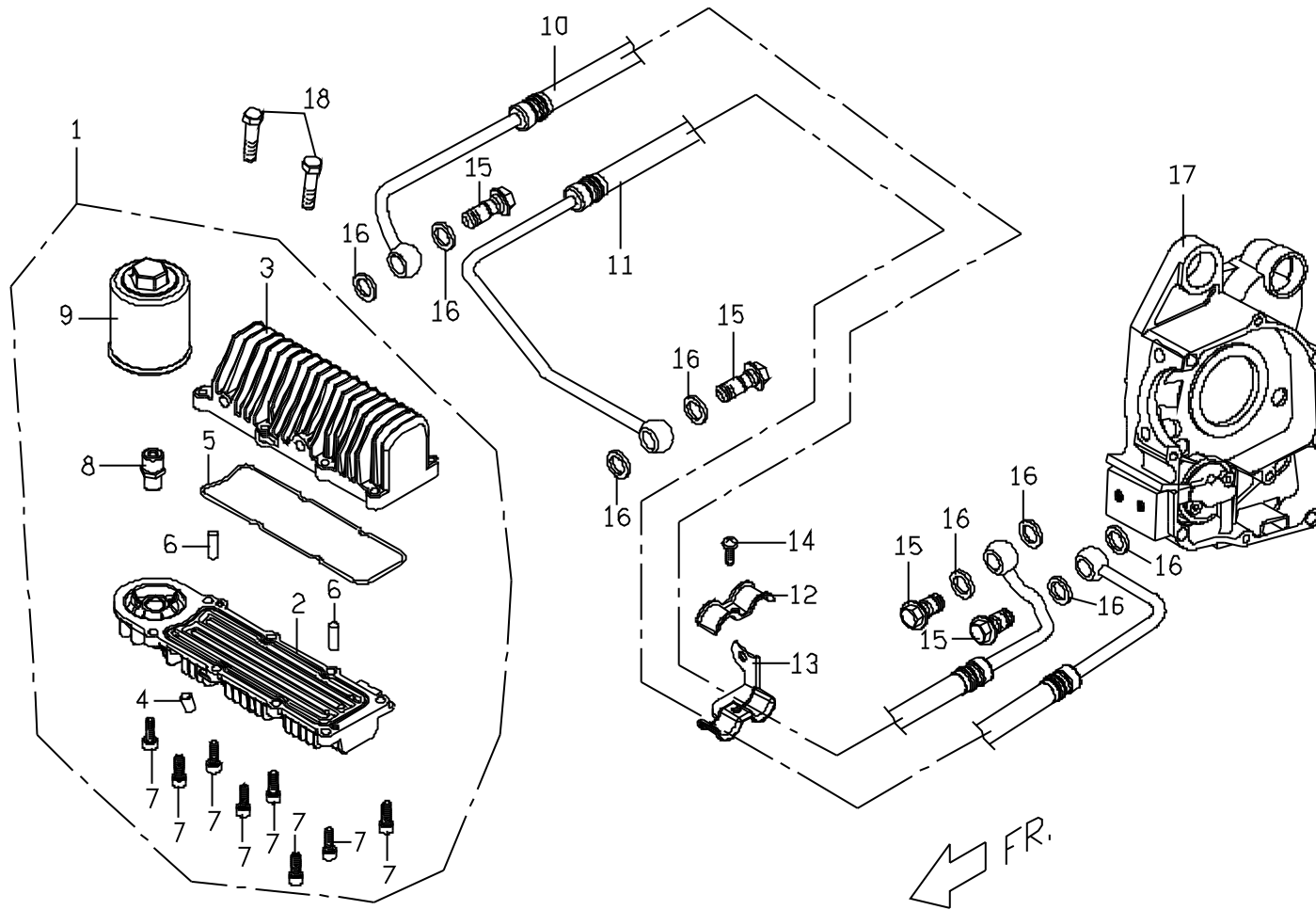

E15

空氣導入控制閥總成
AIAC ASSY. (OPTIONAL DEVICE)

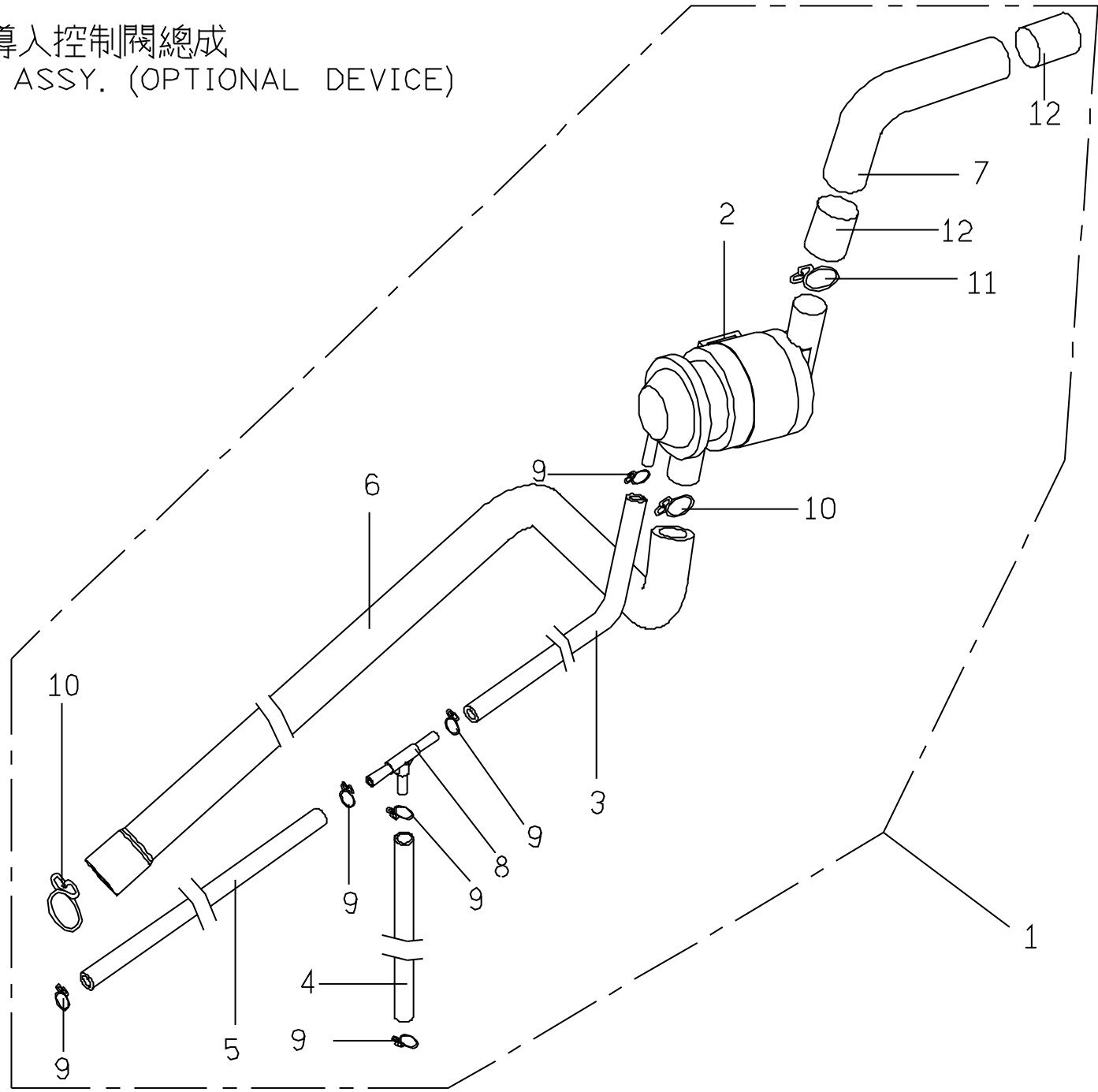

FR.

E15. 空氣導入控制閥總成 / AIAC ASSY. (OPTIONAL)

OPTIONAL DEVICE FOR EMISSION REGULATION

No.	Part No.	Q'TY	PART NAME	PART NAME	REMARK
項目	零件號碼	數量	零件中文名稱	零件英文名稱	備註
1	M2286300000	1	空氣導入控制閥總成	AIAC SYSTEM	
2	P62862100001	1	空氣導入控制閥組合	REED VALVE ASSY.	
3	M2286240000	1	負壓管 (A)	VACUUM PIPE (A)	
4	C1286250000	1	負壓管 (B)	VACUUM PIPE (B)	
5	M2286260000	1	負壓管 (C)	VACUUM PIPE (C)	
6	M2286270000	1	通氣管 (A)	BREATHING PIPE (A)	
7	P6286270000	1	通氣管 (B)	BREATHING PIPE (B)	
8	C1286290000	1	三通管座	3 WAY CONNECTOR	
9	92200700000	5	軟管夾	CLIP	
12	C1286310000	2	消音棉	SPONGE	

F1 方向把手前後蓋。方向把手管。遮陽板
COVERUPPER&LOWER.HANDLE BAR.
SUN PLATE.

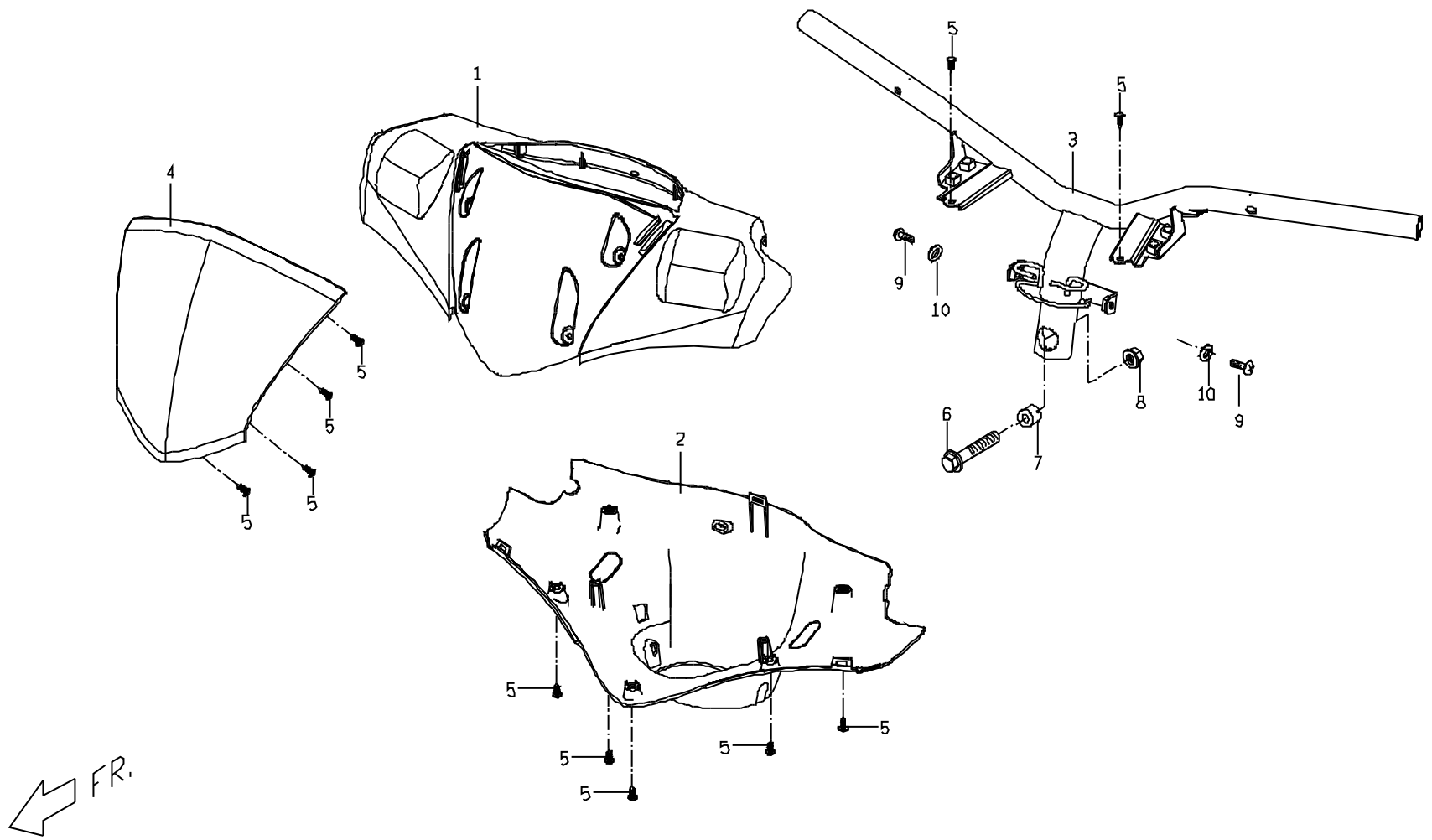

F2 碼 錶
SPEEDOMETER

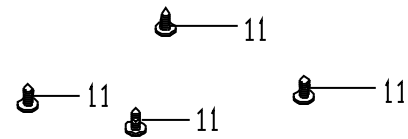
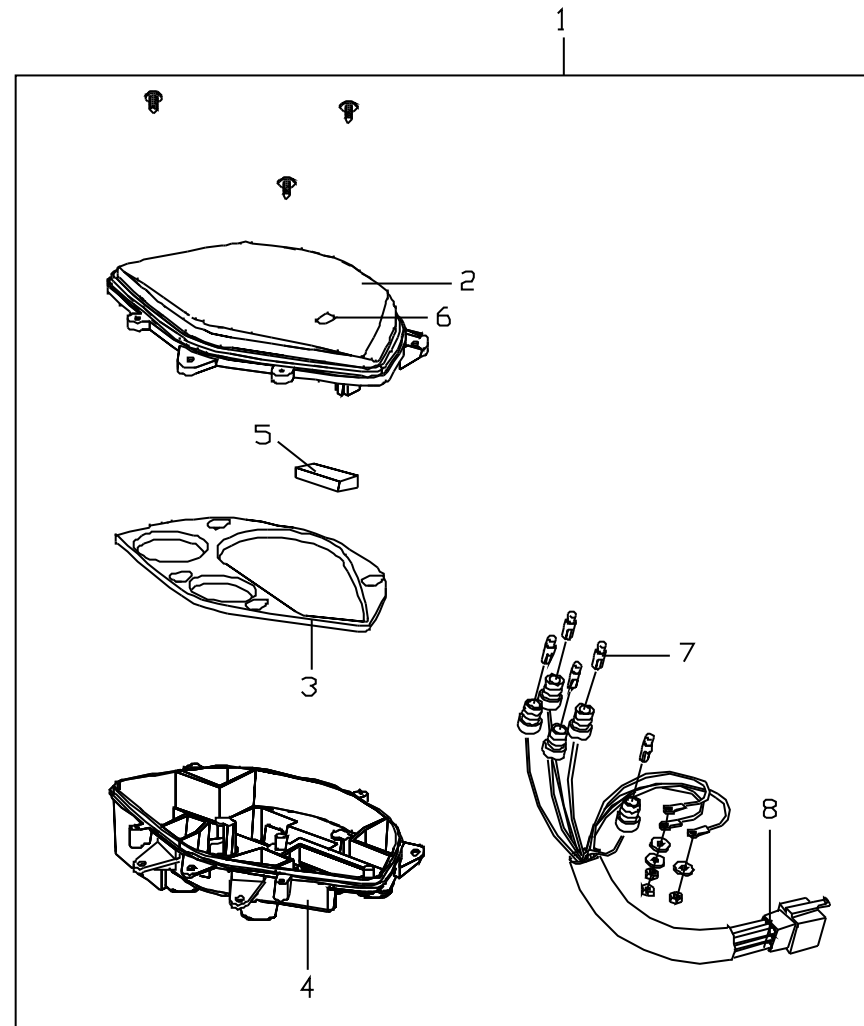
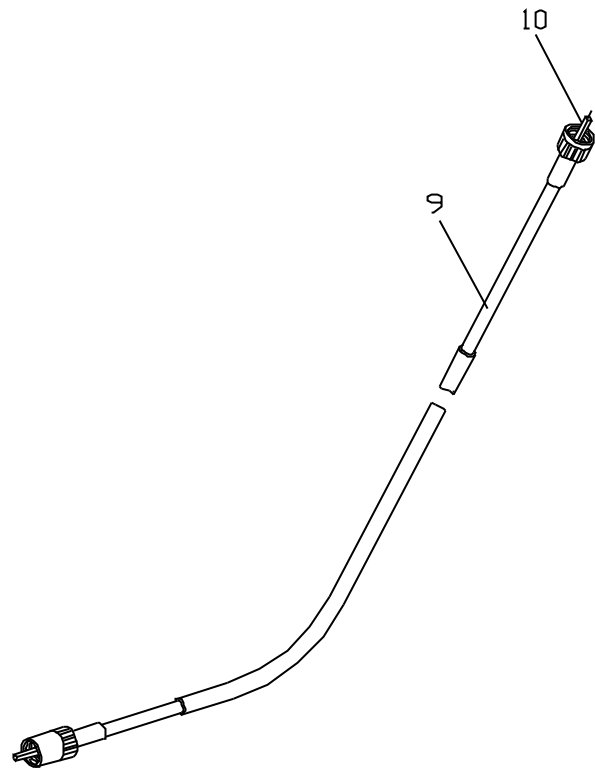

F3.2 導線。開關。後視鏡 (前碟後碟)
 CABLE, SWITCH, BACK MIRROR

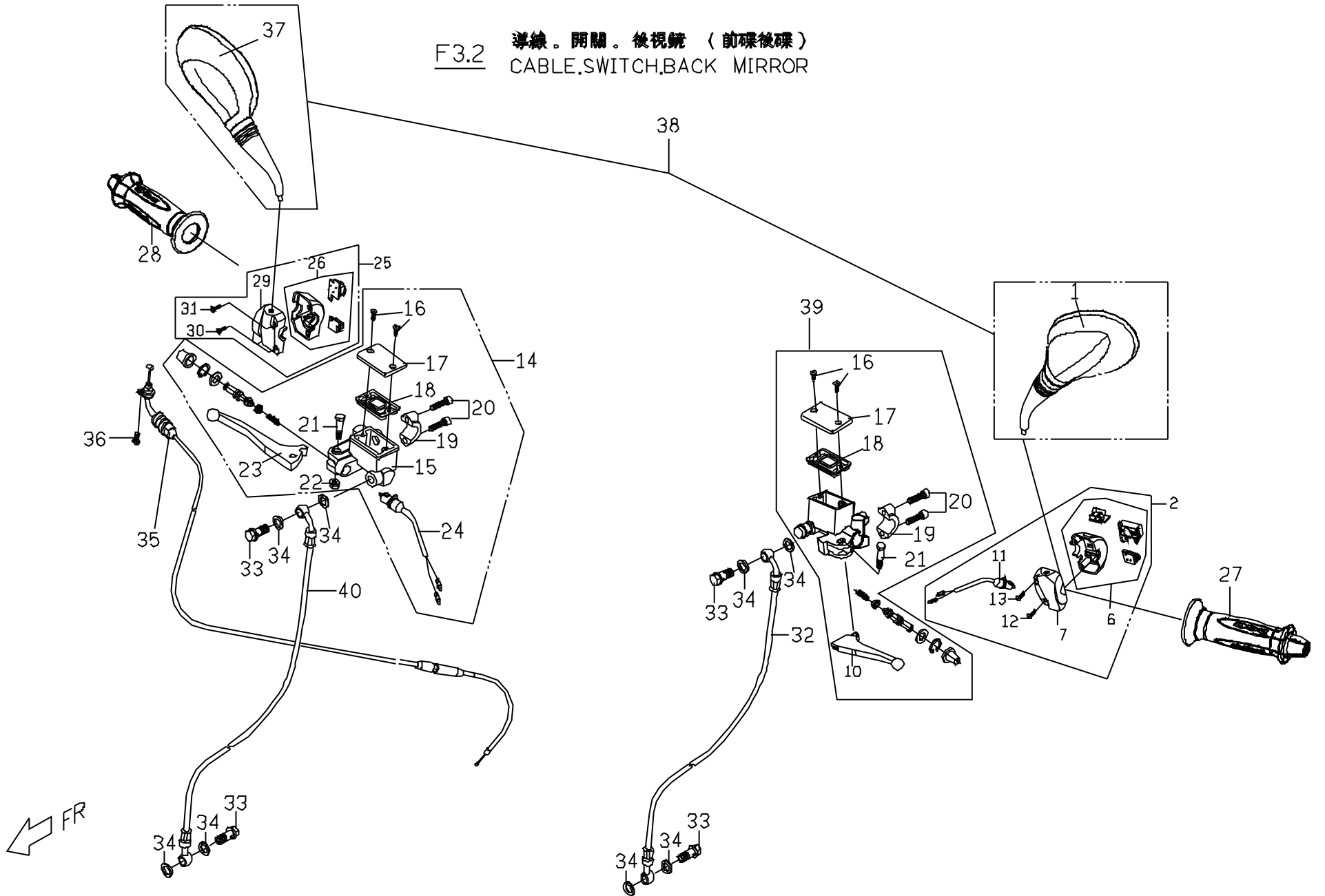

F3.2 導線/開關/後視鏡 / CABLE.SWITCH.BACK MIRROR

Available for (M2-125/150)

No.	Part No.	Q'TY	PART NAME	PART NAME	REMARK
項目	零件號碼	數量	零件中文名稱	零件英文名稱	備註
1	P261F010000	1	左後視鏡	LH BACK MIRROR	
2	M2546000000	1	左把手開關總成(C2小改)	HANDLEBAR SWITCH ASSY, LH	
6	C254F0300005	1	內夾持板2組合	CASE,SWITCH UNDER 2 ASSY.	
7	M254F020000	1	內夾持板1	CASE,SWITCH UNDER 1	
10	M240C190000	1	煞車拉桿	LEVER,LH BRAKE	
11	P140C180000	1	煞車安全開關組合	STOP SWITCH COMP	
12	P154F390000	1	埋頭螺釘	SCREW,PAN HEAD	
13	P154F400000	1	埋頭螺釘	SCREW,PAN HEAD	
14	M2403000000	1	前煞車總泵	MASTER CYLINDER, FR BRAKE	
16	P140C130000	2	螺絲	SCREW	
17	P140C120000	1	油杯蓋	CAP,RESERVOIR	
18	P140C110000	2	皮膜	DIAPHRAGM,RESERVOIR	
19	P1402400000	2	夾持具	BRACKET,MASTER CYLINDER	
20	P1402500000	2	內六角螺栓	HEX SOCKET HEAD BOLT	
21	P140C220000	2	螺栓	BOLT	
22	P140C230000	2	凸緣螺帽	FLANGE NUT	
23	M240C190000	1	煞車拉桿	LEVER,RH BRAKE	
24	P140C180000	1	右安全開關	SWITCH COMP	
25	P25480000001	1	右把手開關總成	SWITCH ASSY.RH HANDLEBAR	
26	P254H0100001	1	內夾持板2組合	CASE,SWITCH UNDER 2 ASSY.	
27	C25410000001	1	左握把總成	GRIP ASSY, LH	
28	C25420000001	1	右握把總成	GRIP ASSY, RH	
29	P154H020000	1	內夾持板1	CASE,SWITCH UNDER 1	
30	P154F400000	1	十字槽圓頭螺栓	C-R ROUND HD TAPPING	
31	P154F390000	1	十字槽圓頭螺栓	C-R ROUND HD TAPPING	
32	M2403700000	1	後煞車油管總成	REAR BRAKING TUBE	
33	P1403810000	1	煞車油管通油螺栓	JOINT BOLT,BRAKE HOSE	
34	92141000002	4	平墊圈	PLAIN WASHER	

F3.2 導線/開關/後視鏡 / CABLE.SWITCH.BACK MIRROR**Available for (M2-125/150)**

No.	Part No.	Q'TY	PART NAME	PART NAME	REMARK
項目	零件號碼	數量	零件中文名稱	零件英文名稱	備註
35	M2544600000	1	加油導線總成	THROTTLE CABLE	
36	90040501200	1	十字槽盤頭機器螺釘	CR PAN HD MACHINE SCREW(M5*12L)	
37	P261F020000	1	右後視鏡	RH BACK MIRROR	
38	P2616000000	1	後視鏡總成	BACK MIRROR COMP	
39	M2406300000	1	後煞車總泵	REAR BRAKING MASTER CYLINDER	
40	M2403601000	1	前煞車油管		

F4.2 前叉 (125/150CC)
FRONT FORK

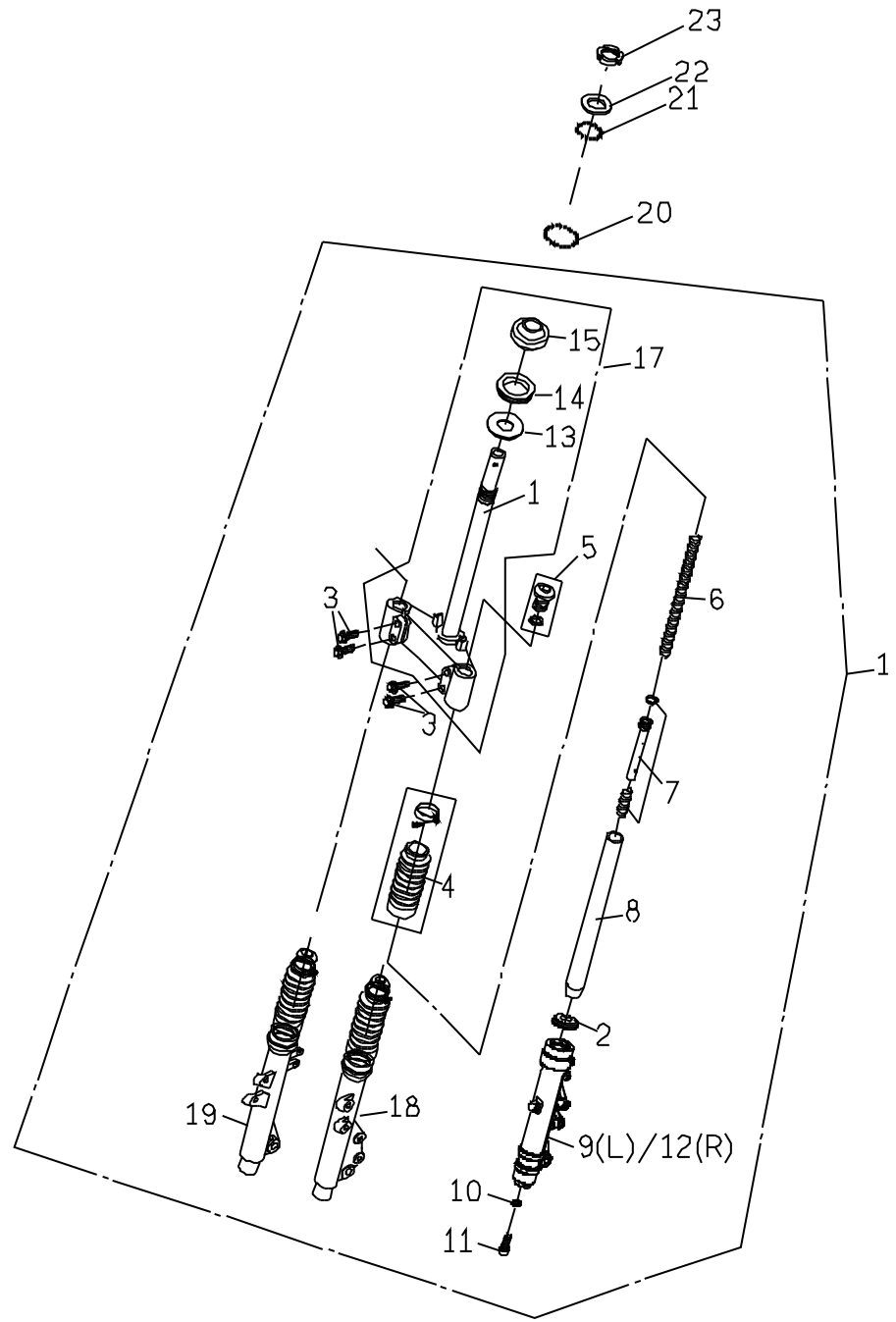
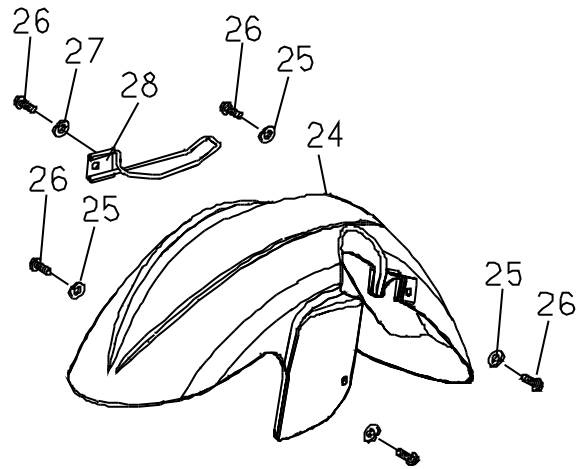

F4.2 前叉 FRONT FORK / M2-125 & M2-150**available for (M2-125/150)**

No.	Part No.	Q'TY	PART NAME	PART NAME	REMARK
項目	零件號碼	數量	零件中文名稱	零件英文名稱	備註
1	M2443001720	1	前叉總成 (散銀色)	FRONT FORK ASSY	
2	C144C160000	2	油封	OIL SEAL	
3	C144C030000	4	螺栓	HEXAGON BOLT	
4	C144C040000	2	橡膠套管	BOOT	
5	C144C050000	2	內筒螺栓組	BOLT ASSY.	
6	M244C061000	2	大彈簧	SPRING, FRONT FORK	
7	NA	2	內油管組	INNER TUBE ASSY.	
8	C144C080000	2	內筒組	INNER.TUBE COMP	
9	NA	1	外筒L	OUTTER TUBE, LH	
10	C144C100000	2	銅墊片	PLAIN WASHER	
11	C144C110000	2	六角螺栓	HEXAGON BOLT	
12	NA	1	外筒R	OUTTER TUBE, RH	
13	C144C130000	1	墊片	GASKET	
14	P244C040000	1	防塵套	COVER	
15	C144C150000	1	下軸承內座	INNER BEARING CAGE	
17	M244C200000	1	下三角架總成	UNDER BRACKET,COMP.	
18	M244C210000	1	左外筒總成	TUBE COMP. LH	
19	M244C220000	1	右外筒總成	TUBE COMP. RH	
20	99010600000	19	鋼珠(1/4")	BEARING BALL(1/4")	
21	99010400000	26	鋼珠 (5/32)	BEARING BALL	
22	E1444050000	1	上座環型螺帽	UPPER RING-SHAPE NUT	
23	E1444040000	1	轉向軸防鬆螺帽	STEERING SHAFT LOCK NUT	
24	M2632001000	1	前土除	FR FENDER	ADD COLOR CODE
25	92140600018	5	平墊圈	PLAIN WASHER	
26	90040601600	6	十字槽盤頭機器螺釘(M6*16L)	CR PAN HD MACHINE SCREW	
27	92110600000	5	彈簧墊圈(6D*1.8T)	SPRING WASHER	
28	M2544020000	1	碼錶導線束圈(右)	SPEEDMETER CABLE CLIP COMP (R)	

F5.2 輪胎。前輪圈。碟式煞車夾 (125/150c,c)
TIRE.FRT WHEEL.FRT CALIPER.

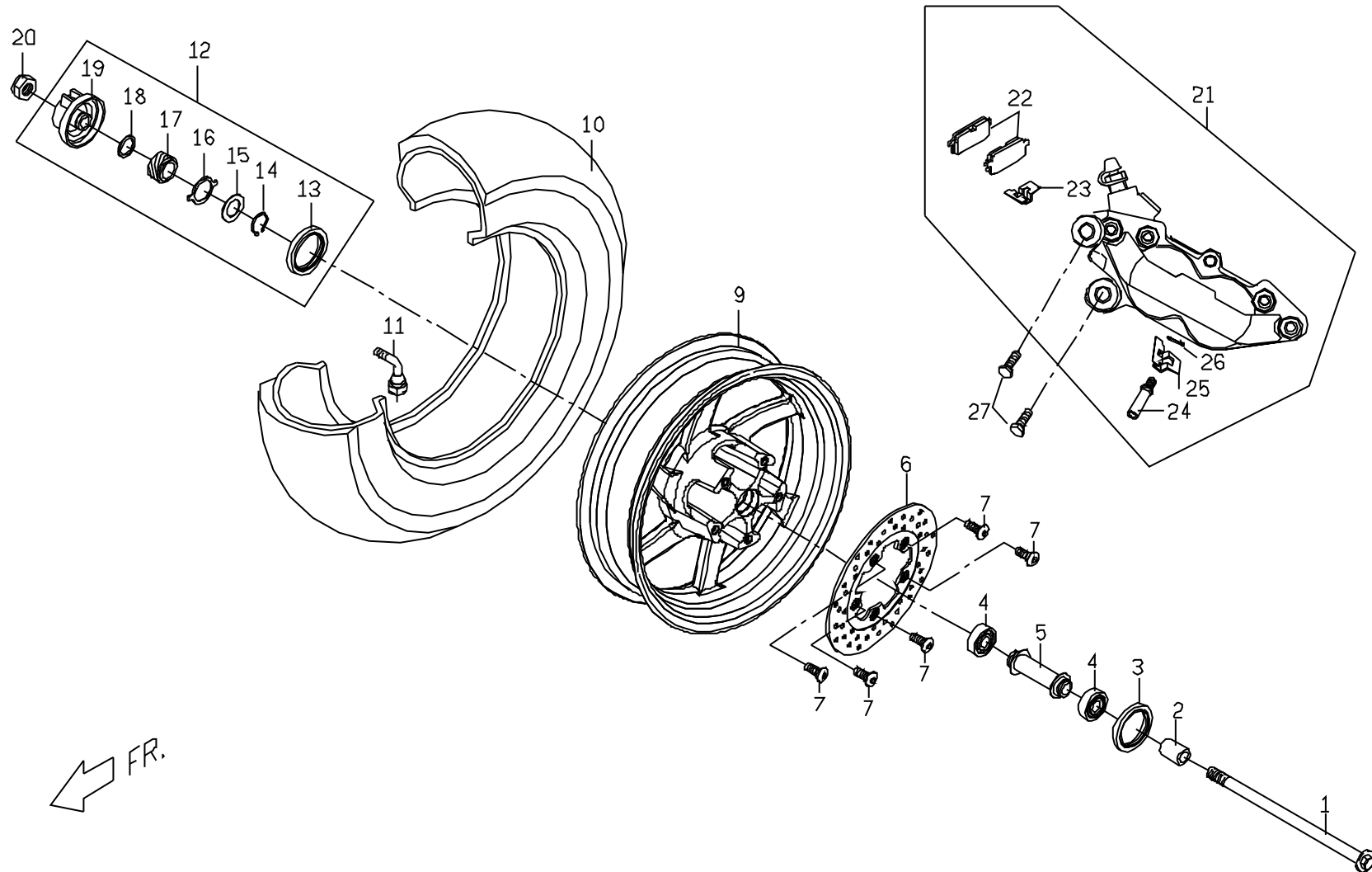

F5.2 前輪圈,碟式煞車夾 /TIRE.FRT WHEEL.FRT CALIPER. M2-125/M2-1

available for (M2-125/150)

No.	Part No.	Q'TY	PART NAME	PART NAME	REMARK
項目	零件號碼	數量	零件中文名稱	零件英文名稱	備註
1	C1402500000	1	前輪軸	AXLE , FR WHEEL	
2	P1401010000	1	間隔環	SPACER	
3	95572235700	1	T C 型油封	OIL SEAL, TC TYPE	
4	96520620100	2	單封滾珠軸承(6201U)	ONE SHIELD BALL BEARING	
5	P9402401000	1	間隔環	SPACER	
6	M2403501000	1	前煞車碟盤	BRAKING DISK	
7	C1403510000	5	前煞車盤螺絲(M8*1.25P*24L)	SCREW, FR BRAKE DISK(M8*1.25P*24L)	
9	M2401101770	1	前輪圈(13") 銀灰色	FRT WHEEL	
10	M240B320000	1	前輪胎總成120/60-13	FRT TIRE	
11	P140B330000	1	氣門嘴	VAVLE	
12	P1566002000	1	碼錶齒輪總成	METER GEAR ASSY	
13	95574052600	1	油封(TC 40 52)	OIL SEAL	
14	92171800000	1	C型扣環	C CLIP	
15	92141900001	1	平墊圈	PLAIN WASHER	
16	P1566050000	1	傳動片	PAD	
17	P1566040000	1	速度表齒輪	SPEEDOMETER GEAR	
18	92141900002	1	平墊圈	PLAIN WASHER	
20	92061200000	1	防鬆螺帽(M12*1.25P)	LOCK NUT(M12*1.25P)	
21	M2403301000	1	前煞車夾總成	BRAKE CALIPER, FRONT	
22	M240C010000	1	煞車片組成	PAD ASSY.	
23	M240C020000	1	軛簧	YOKE SPRING	
24	M240C040000	1	彈簧銷	SPRING PIN	
26	M240C030000	1	扣環	CLIP	
27	90191004003	2	六角凸緣螺栓	HEXAGON FLANGE BOLT (M10*40L)	

F6 擋風板。前內蓋。前大燈
WINDSHIELD.FRT INNER CONER.
FRT HEAD LIGHT,

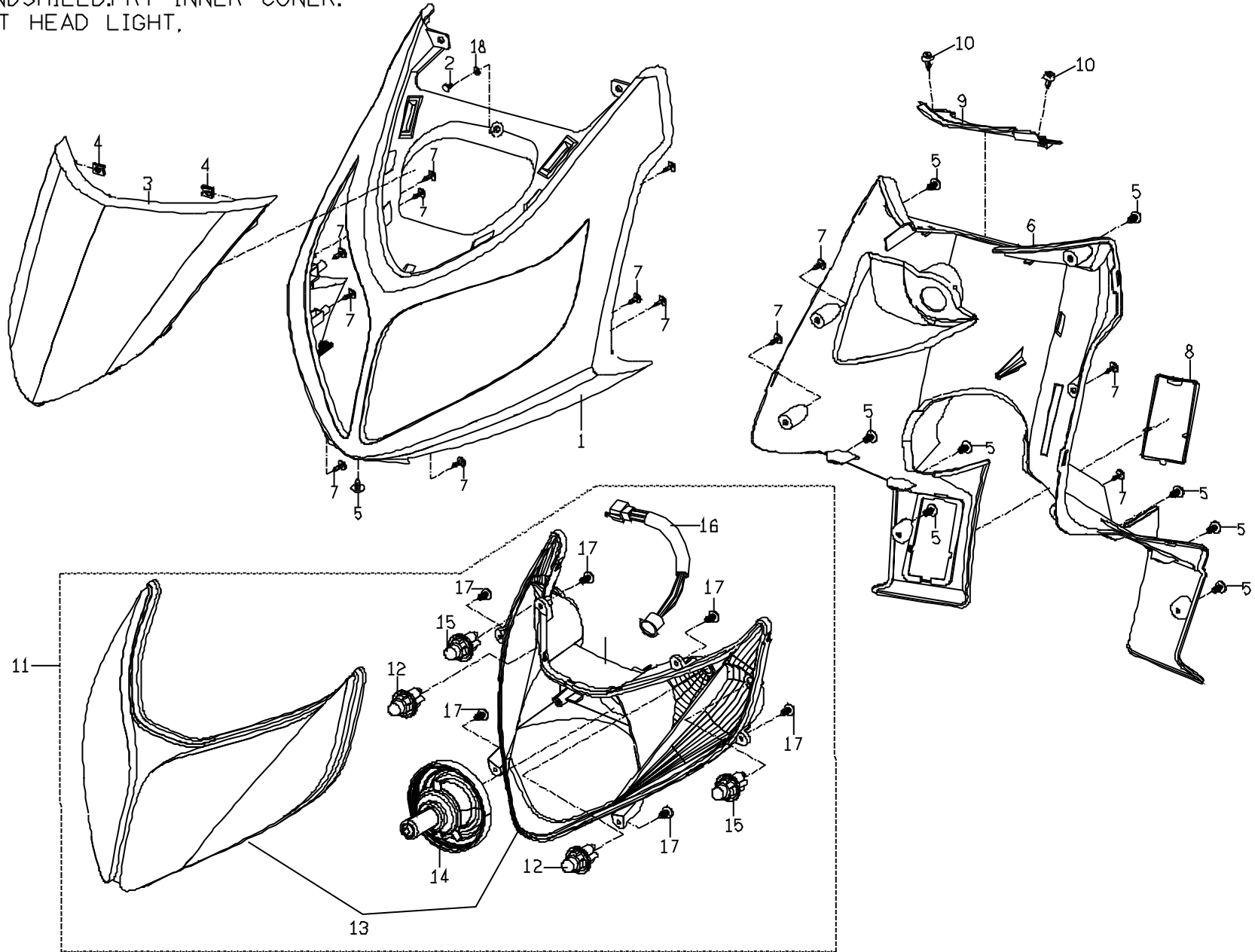

F6 擋風板/前內蓋/前大燈/WINDSHIELD.FRT INNER CONER. FRT HEAD LIGHT.

No.	Part No.	Q'TY	PART NAME	PART NAME	REMARK
項目	零件號碼	數量	零件中文名稱	零件英文名稱	備註
1	M26210001N0	1	擋風板	WIND SHIELD(RED)	RED
1	M26210004W0	1	擋風板	WIND SHIELD(BLUE)	BLUE
1	M26210007L0	1	擋風板	WIND SHIELD(SILVER)	SILVER
2	90040601400	2	十字槽盤頭機器螺釘(M6*14L)	CR PAN HD MACHINE SCREW(M6*14L)	
3	M2621010690	1	擋風板飾蓋	WINSHIELD,OUTER COVER	
4	92370500003	2	U型彈簧螺帽(M5)	U TYPE SPRING NUT	
5	90130501400	9	十字槽扁圓頭自攻螺釘(M5*16L)	CR TRUSS HD TAPPING SCREW (M5*16L)	
6	M2623001650	1	前內蓋	INNER COVER,FRT	
7	90130501400	4	十字槽圓頭自攻螺釘(M5*14L)	CR ROUND HD TAPPING SCREW (M5*14L)	
8	M2623010650	1	車身號碼牌蓋	COVER,VIN	
9	M2623020650	1	前內蓋飾蓋	PANEL,FRT.INNER COVER	
10	M2701010000	2	快速鉚釘	PUSH RIVET	
11	M2661000000	1	頭燈組合(內銷)	HEAD LIGHT ASSY.	GENERAL
12	98231230000	2	位置燈(內)	POSITION LAMP (INSIDE, 3W)	GENERAL
13	M266A020000	1	燈殼組合	DUMMY HEADLAMP ASSY.	GENERAL
14	98151235351	1	頭燈泡	HEADLAMP BULB (35/35W)	GENERAL
15	98231205000	2	位置燈(外)	POSITION LAMP (OUTSIDE,5W)	GENERAL
16	M266A010000	1	電線組合	WIRE ASSY.	GENERAL
17	90130501400	6	十字槽圓頭自攻螺釘(M5*14L)	CR ROUND HD TAPPING SCREW (M5*14L)	
18	92140600005	1	平墊圈(6.4D*13D*1T)	WASHER (6.4D*13D*1T)	

F7 脚踏板。
STEP FLOOR, STEP PLATE.

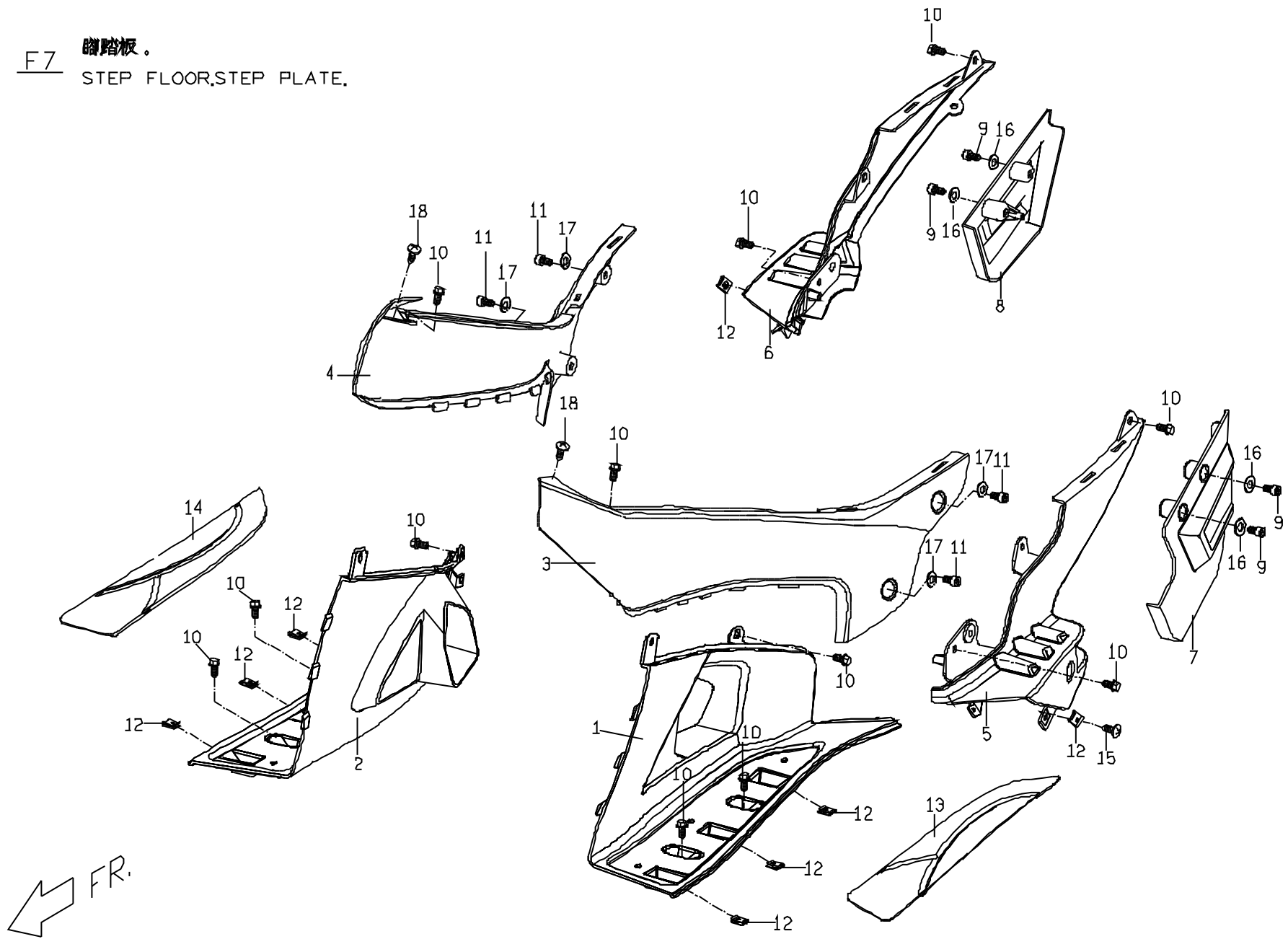

F8 前下蓋。脚踏板下腹蓋。前土除
FRT LOWER COVER,STEPFLOOR LOWER
COVER,FRONT FENDER

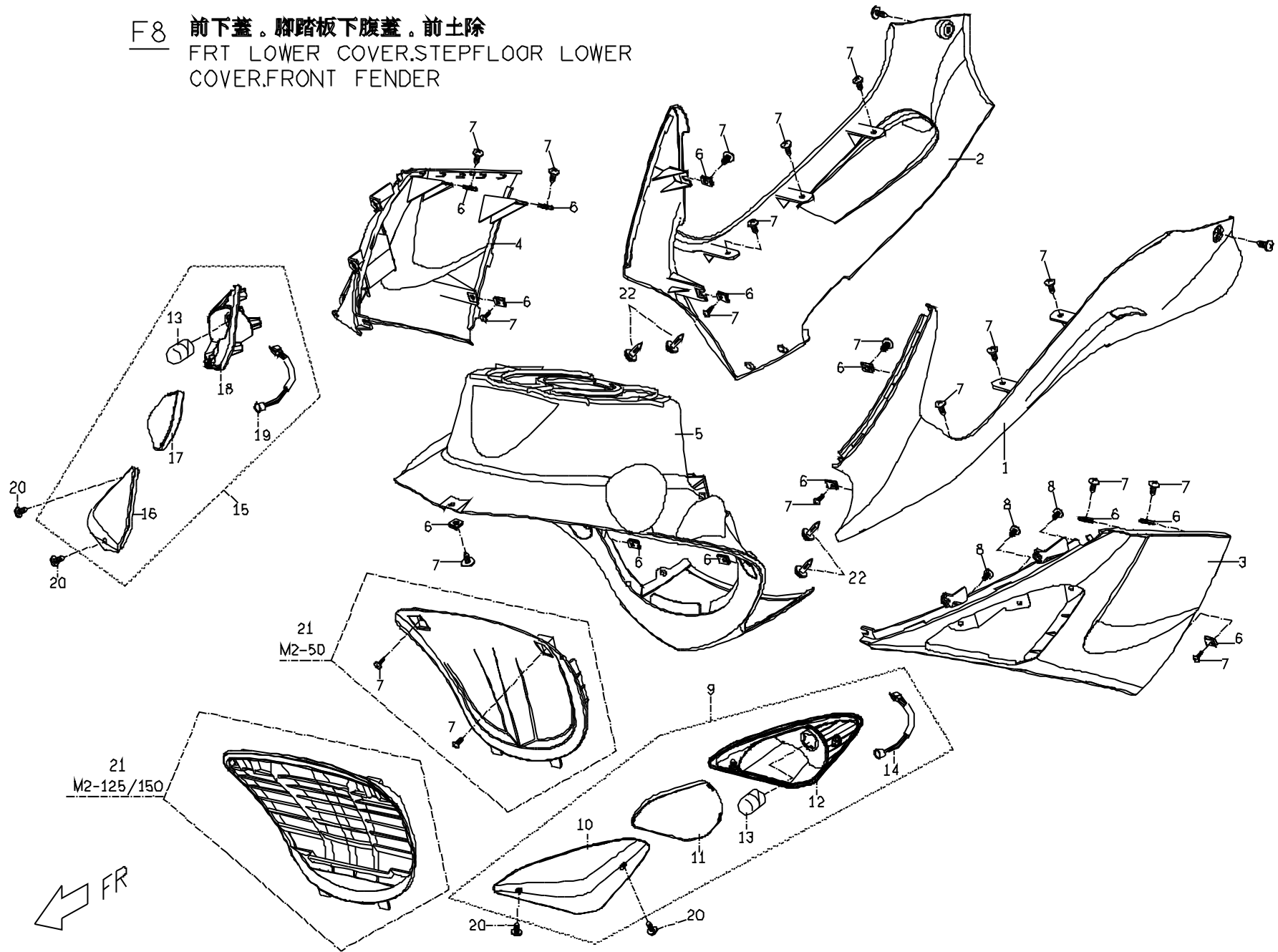

F8 前下蓋/腳踏板下腹蓋/前土除 / FRT LOWER COVER.STEPFLOOR LOWER COVER.FRONT FENDER

No.	Part No.	Q'TY	PART NAME	PART NAME	REMARK
項目	零件號碼	數量	零件中文名稱	零件英文名稱	備註
1	M26263007L0	1	下護蓋(左)	LOWER COVER(LEFT)	SILVER
2	M26265007L0	1	下護蓋(右)	LOWER COVER(RIGHT)	SILVER
3	M26213001N0	1	前方向燈飾蓋(左)	TURN SIGNAL FRONT ASSY,INNER COVER(LH)	RED
3	M26213004W0	1	前方向燈飾蓋(左)	TURN SIGNAL FRONT ASSY,INNER COVER(LH)	BLUE
3	M2621300690	1	前方向燈飾蓋(左)	TURN SIGNAL FRONT ASSY,INNER COVER(LH)	BLACK
4	M262A3001N0	1	前方向燈飾蓋(右)	TURN SIGNAL FRONT ASSY,INNER COVER(RH)	RED
4	M262A3004W0	1	前方向燈飾蓋(右)	TURN SIGNAL FRONT ASSY,INNER COVER(RH)	BLUE
4	M262A300690	1	前方向燈飾蓋(右)	TURN SIGNAL FRONT ASSY,INNER COVER(RH)	BLACK
5	M2633001650	1	前內擋泥板	LOWER COVER,FRONT	
6	92370500003	6	U型彈簧螺帽(M5)	U TYPE SPRING NUT	
7	90130501400	2	十字槽扁圓頭自攻螺釘(M5*16L)	CR TRUSS HD TAPPING SCREW (M5*16L)	
8	90130501400	6	十字槽圓頭自攻螺釘(M5*14L)	CR ROUND HD TAPPING SCREW (M5*14L)	
9	ACCORDING BOM	1	左前方向燈組合	SIGNAL LAMP ASSY., LH	OPTIONAL PART
9	M266C120000	1	左前方向燈組合	SIGNAL LAMP ASSY., LH	
9	M266C1200001	1	左前方向燈組合	SIGNAL LAMP ASSY., LH	E-MARK,EURO
10	M266C020000	1	左前方向燈蓋	LAMP COVER, LH	
11	M266C030000	1	左濾光罩	LIGHT FILTER, LH	E-MARK,EURO
12	M266C010000	1	左前方向燈座	SIGNAL LAMP BASE, LH	
13	98221210990	2	方向燈泡	BULB (ORANGE)	10W
13	98241216001	2	方向燈泡	BULB (WHITE)	16W,E-MARK
14	M266C060000	1	左電線組	CONNECTING WIRE, LH	
14	M266C0600001	1	左電線組	CONNECTING WIRE, LH	
15	ACCORDING BOM	1	右前方向燈組合	TURN SIGNAL FRONT COMP.,RH	OPTIONAL PART
15	M266D120000	1	右前方向燈組合	TURN SIGNAL FRONT COMP.,RH	
15	M266D1200001	1	右前方向燈組合	TURN SIGNAL FRONT COMP.,RH	E-MARK,EURO
16	M266D020000	1	右前方向燈蓋	LAMP COVER, RH	
17	M266D030000	1	右濾光罩	LIGHT FILTER, RH	E-MARK,EURO
18	M266D010000	1	右前方向燈座	SIGNAL LAMP BASE, RH	
19	M266D060000	1	右電線組	CONNECTING WIRE, RH	
19	M266D0600001	1	右電線組	CONNECTING WIRE, RH	E-MARK,EURO

F9 車身蓋。中間蓋。後行李架。車身下腹蓋。
BODY COVER.MIDDLE COVER.
RR LUGGAGE,BODY LOWER COVER,

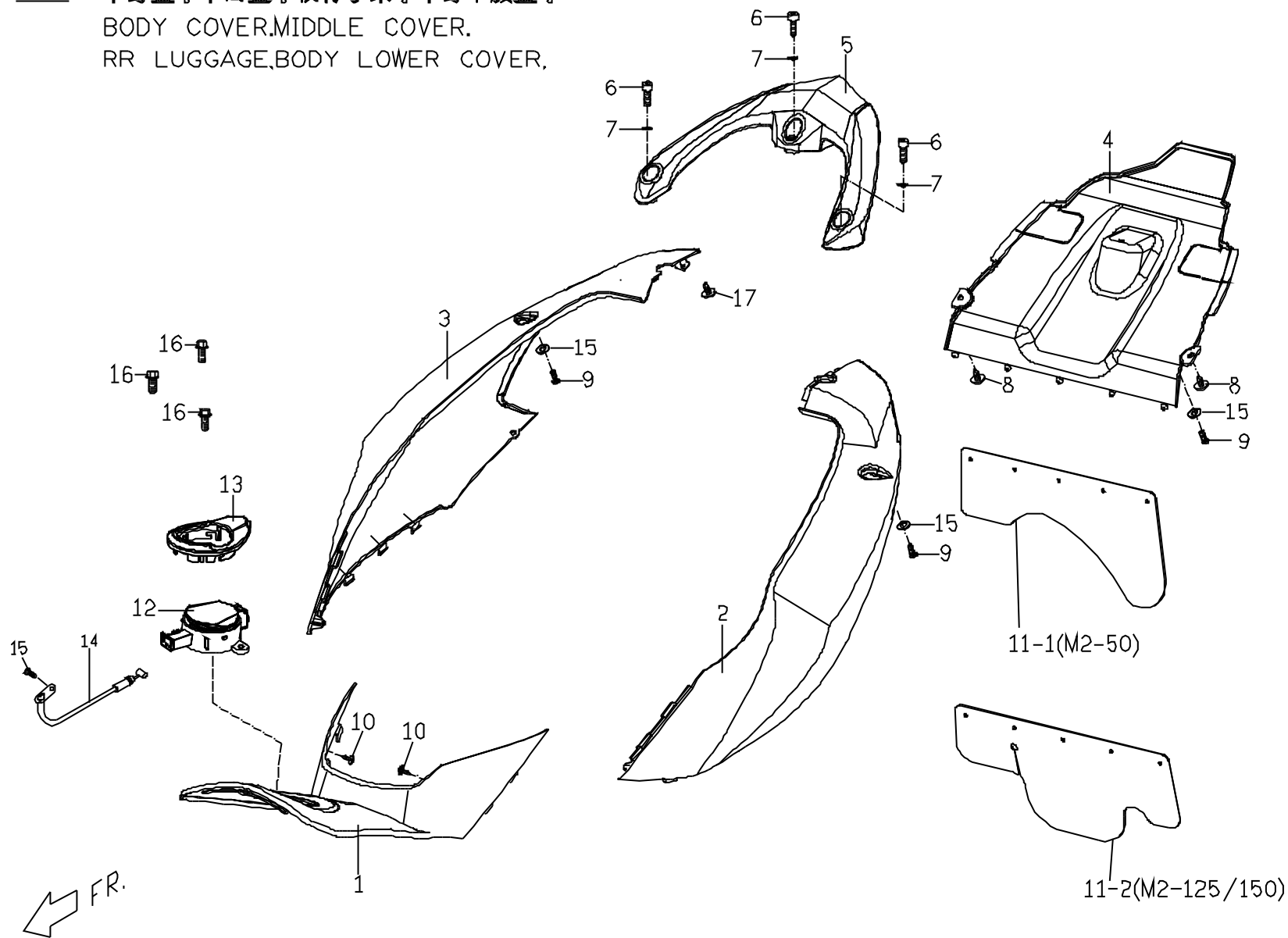

F9 車身蓋/中間蓋/後行李架/車身下腹蓋 / BODY COVER.MIDDLE COVER. RR LUGGAGE.BODY LOWER COVER.

No.	Part No.	Q'TY	PART NAME	PART NAME	REMARK
項目	零件號碼	數量	零件中文名稱	零件英文名稱	備註
1	M2625010650	1	油箱飾蓋	FUEL TANK COVER,FR.	
2	M26253001N0	1	左車身蓋	BODY COVER,LH(RED)	RED
2	M26253004W0	1	左車身蓋	BODY COVER,LH(BLUE)	BLUE
2	M26253007N0	1	左車身蓋	BODY COVER,LH(GREY)	GREY
3	M26255001N0	1	右車身蓋	BODY COVER,RH(RED)	RED
3	M26255004W0	1	右車身蓋	BODY COVER,RH(BLUE)	BLUE
3	M26255007N0	1	右車身蓋	BODY COVER,RH(GREY)	GREY
4	M2625020650	1	車身下腹蓋	BODY COVER,LOWER	
5	M2676000000	1	後行李架	RR LUGGAGE BRACKET	
6	90210803504	3	六角承窩螺栓	HEXAGON SOCKET HEAD BOLT	
7	92140800010	3	平墊圈(8.4D*17D*1.6T)	WASHER (8.4D*17D*1.6T)	
8	90130501400	2	十字槽盤頭機器螺釘(M6*14L)	CR PAN HD MACHINE SCREW(M6*14L)	
9	90040601400	1	十字槽盤頭機器螺釘(M6*14L)	CR PAN HD MACHINE SCREW(M6*14L)	
10	90130501400	1	十字槽圓頭自攻螺釘(M5*14L)	CR ROUND HD TAPPING SCREW (M5*14L)	
11	M27010200001	1	防水護墊	WATER PROTECTIVE RUBBER	M2-50
11	M27010200000	1	防水護墊	WATER PROTECTIVE RUBBER	M2-125/M2-150
12	M252A3000001	1	油箱蓋(外銷)電鍍	TANK COVER	W/O EEC SYSTEM
12	M252A3000000	1	油箱蓋(內銷)電鍍	TANK COVER	W/H EEC SYSTEM
13	M252A3200000	1	油箱蓋飾蓋(電鍍)	TANK ,INNER COVER	
14	M25213100000	1	油箱蓋拉桿線	TANK COVER LEVER CABLE	
15	921406000005	2	平墊圈(6.4D*13D*1T)	WASHER (6.4D*13D*1T)	
16	90190601500	3	六角凸緣螺栓(M6*15L)	HEXAGON FLANGE BOLT (M6*15L)	
17	90040501200	1	十字槽盤頭機器螺釘	CR PAN HD MACHINE SCREW(M5*12L)	

F10 座墊, 前置物箱, 後置物箱
 SEAT, FR LUGGAGE,
 BACK LUGGAGE .

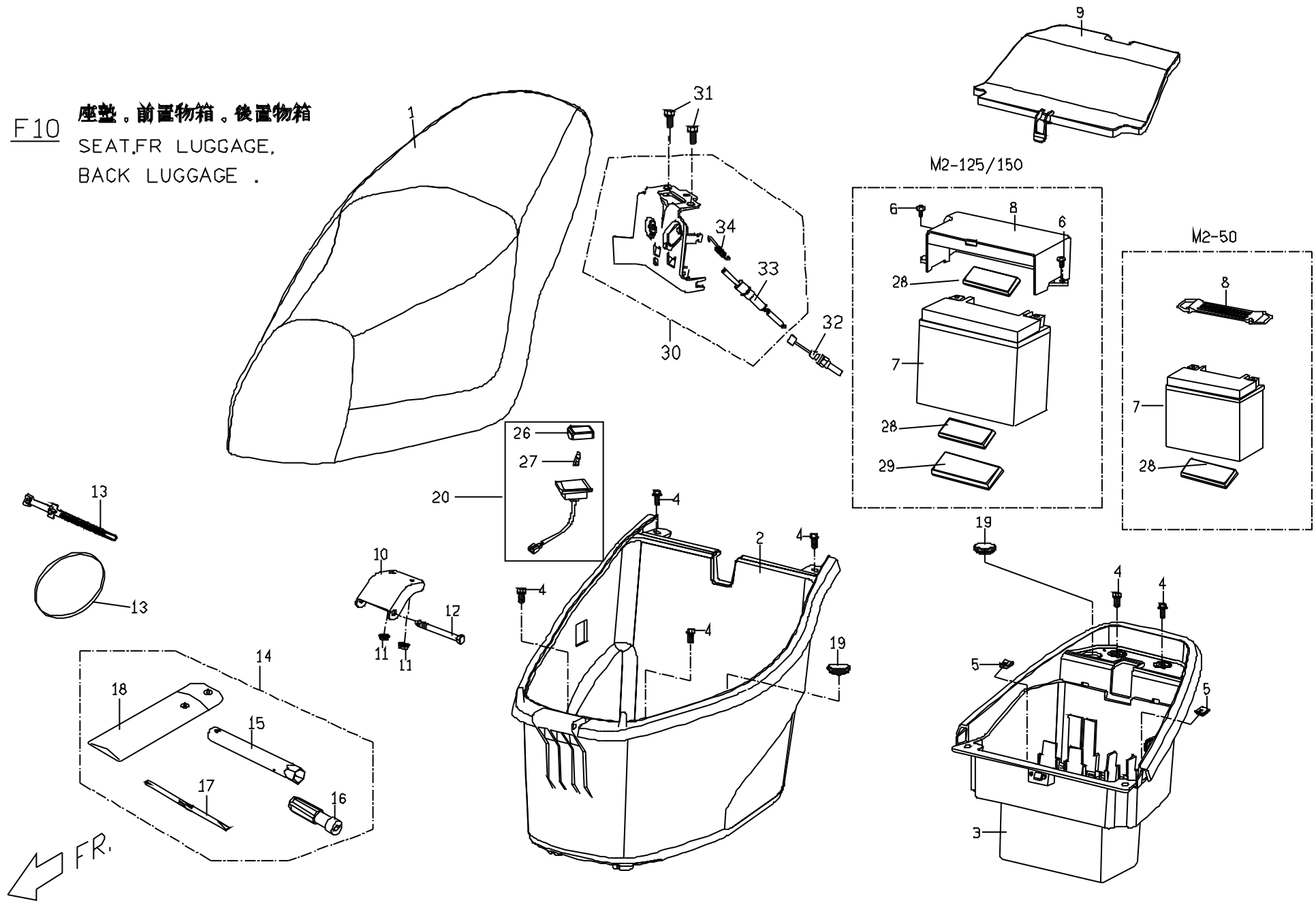

F10座墊/前置物箱/後置物箱/ SEAT.FR LUGGAGE. BACK LUGGAGE

No.	Part No.	Q'TY	PART NAME	PART NAME	REMARK
項目	零件號碼	數量	零件中文名稱	零件英文名稱	備註
1	M2671001000	1	座墊總成	SEAT COMP. (ANTI-SLIP)	外銷/OVERSEAS
1	M26710010001	1	座墊總成	SEAT COMP.	內銷
2	M26810010001	1	置物箱(前)	HELMET CASE ASSY., FRT SECTION	M2-50
2	M2681001000	1	置物箱(前)	HELMET CASE ASSY., FRT SECTION	M2-125/M2-150
3	M26810100001	1	置物箱(後)	HELMET CASE ASSY., REAR SECTION	M2-50
3	M2681010000	1	置物箱(後)	HELMET CASE ASSY., REAR SECTION	M2-125/M2-150
4	90200602001	6	六角凸緣螺栓(M6*1.0P)	HEXAGON FLANGE BOLT (M6*1.0P)	
5	92370500003	2	U型彈簧螺帽(M5)	U TYPE SPRING NUT	
6	90040601400	2	十字槽盤頭機器螺釘(M6*14L)	CR PAN HD MACHINE SCREW(M6*14L)	M2-125/M2-150
7	P5583000000	1	電瓶(4L)	BATTERY(4L)	M2-50
7	C2583000000	1	電瓶(湯淺) 7A	BATTERY(7L)	M2-125/M2-150
8	E1583020000	1	電瓶束帶	BATTERY CLIP	M2-50
8	M2624050650	1	電瓶固定蓋	BATTERY COVER	M2-125/M2-150
9	M2624030650	1	電瓶蓋	COVER,ELECTRICAL UNITS	
10	C1681060000	1	前取付	BRACKET, LUGGAGE	
11	92040600000	2	六角凸緣螺帽(M6*1.0P)	HEXAGON FLANGE NUT (M6*1.0P)	
12	C1681070000	1	特殊螺栓	SPECIAL BOLT	
13	M2701040000	1	可拆式束帶	REMOVEABLE CABLE TIE	
14	P1706541000	1	工具包總成	TOOL KIT	M2-50
14	P6706540000	1	工具包總成	TOOL KIT	M2-125/M2-150
19	C1042030000	2	橡膠塞	RUBBER PLUG	
20	M2681020000	1	置物箱照明燈	LUGGAGE LIGHTING LAMP	
26	M268A010000	1	燈殼	COVER,LUGGAGE LIGHTING LAMP	
27	M268A040000	1	燈泡	BULB	
28	C158C110000	2	電瓶襯墊	DAMPER, BATTERY	M2-125/M2-150
29	P15830100001	1	電瓶襯墊	DAMPER, BATTERY	M2-125/M2-150
30	M2671301000	1	座墊鎖座總成	SEATLOCK ASSY	
31	90040601400	2	十字槽盤頭機器螺釘(M6*14L)	CR PAN HD MACHINE SCREW(M6*14L)	
32	C2671120000	1	座墊鎖拉桿線	SEAT LOCK LEVER CABLE	
33	M267A320000	1	置物箱開啓開關	LIGTING SENSOR	

F11

牌照板。反光片。後燈。

LICENSE PLATE, REFLECTOR,
BACK LAMP.

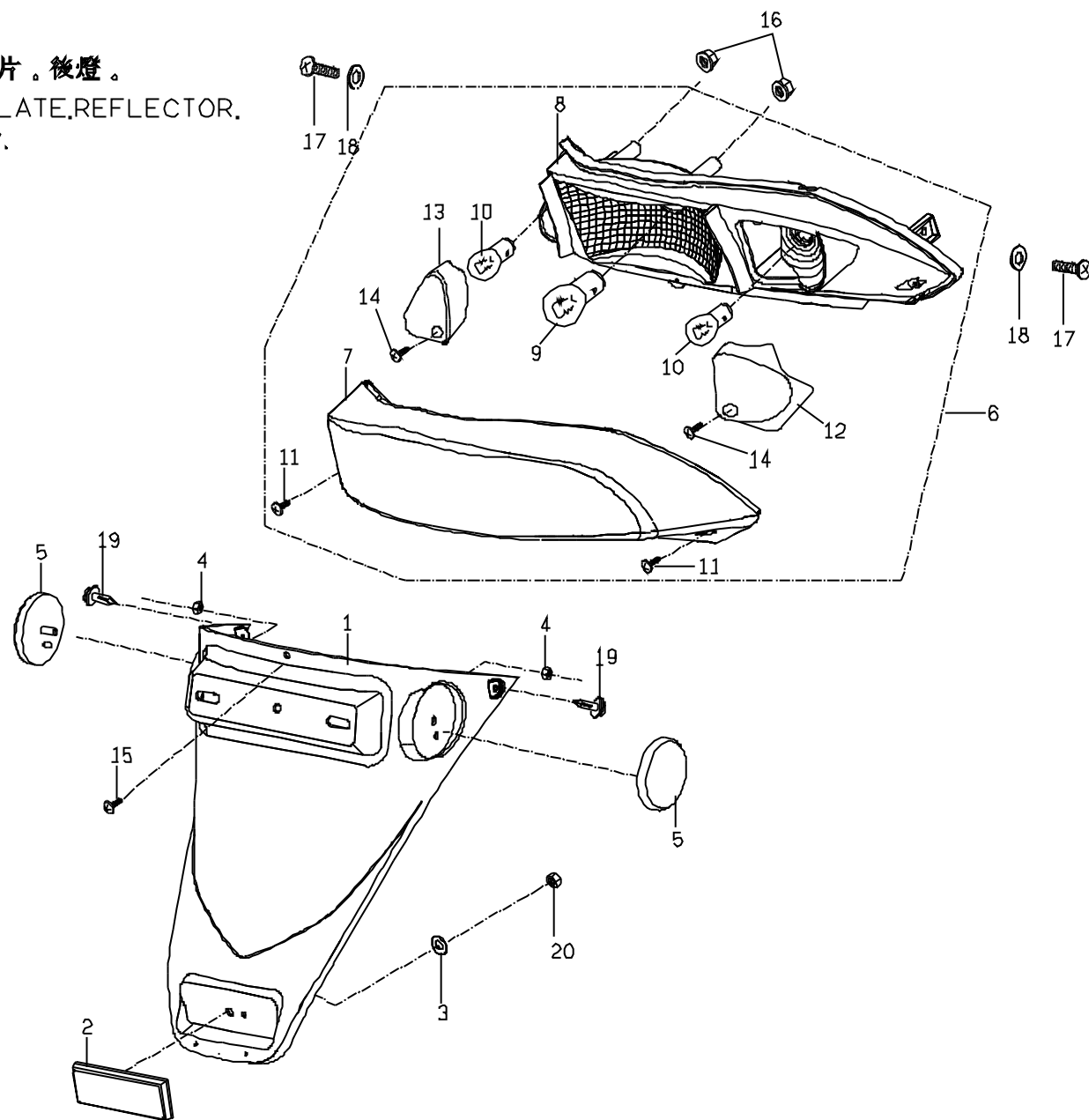

F11 牌照板/反光片/後燈 / LICENSE PLATE.REFLECTOR. BACK LAMP.

No.	Part No.	Q'TY	PART NAME	PART NAME	REMARK
項目	零件號碼	數量	零件中文名稱	零件英文名稱	備註
1	M2636001650	1	牌照板	LICENCE PLATE	
2	C5669000000	1	後反光片 DOT	REFLECTOR DOT	
3	92140500014	1	平墊圈	PLAIN WASHER	
4	92040600000	2	六角凸緣螺帽(M6*1.0P)	HEXAGON FLANGE NUT (M6*1.0P)	
5	C1669000000	2	側反光片(橘黃色)	REFLECTOR SIDE	
6	M2666000000	1	後燈總成	REAR LAMP ASSY.	GENERAL,DENMARK
7	M266F010000	1	燈殼組	COVER	GENERAL,DENMARK
8	M266F080000	1	底座組	BASE	GENERAL,DENMARK
9	98311221050	1	煞車燈泡	BRAKING BULB	GENERAL,DENMARK
10	98221210990	2	方向燈泡	SIGNAL LAMP (10W)	GENERAL,DENMARK
11	M266F070000	2	自攻螺絲	TAPPING SCREW	GENERAL,DENMARK
14	M266F080000	2	自攻螺絲	TAPPING SCREW	GENERAL,DENMARK
15	90110401200	1	十字槽盤頭自攻螺釘(M4*12L)	CR PAN HD TAPPING SCREW(M4*12L)	
16	92040600000	2	六角凸緣螺帽(M6*1.0P)	HEXAGON FLANGE NUT (M6*1.0P)	
17	90040601400	2	十字槽盤頭機器螺釘(M6*14L)	CR PAN HD MACHINE SCREW(M6*14L)	
18	92140600005	2	平墊圈(6.4D*13D*1T)	WASHER (6.4D*13D*1T)	
19	M2701010000	2	快速鉚釘	PUSH RIVET	
20	92020500000	1	六角螺帽(M5*0.8P)	HEXAGON NUT (M5*0.8P)	
21	P2635001650	1	下段擋泥板	LOWER MUD PROTECTOR, REAR	
22	90110401200	2	十字槽盤頭自攻螺釘(M4*12L)	CR PAN HD TAPPING SCREW(M4*12L)	

F12.2 車架 (125/150c.c)
FRAME

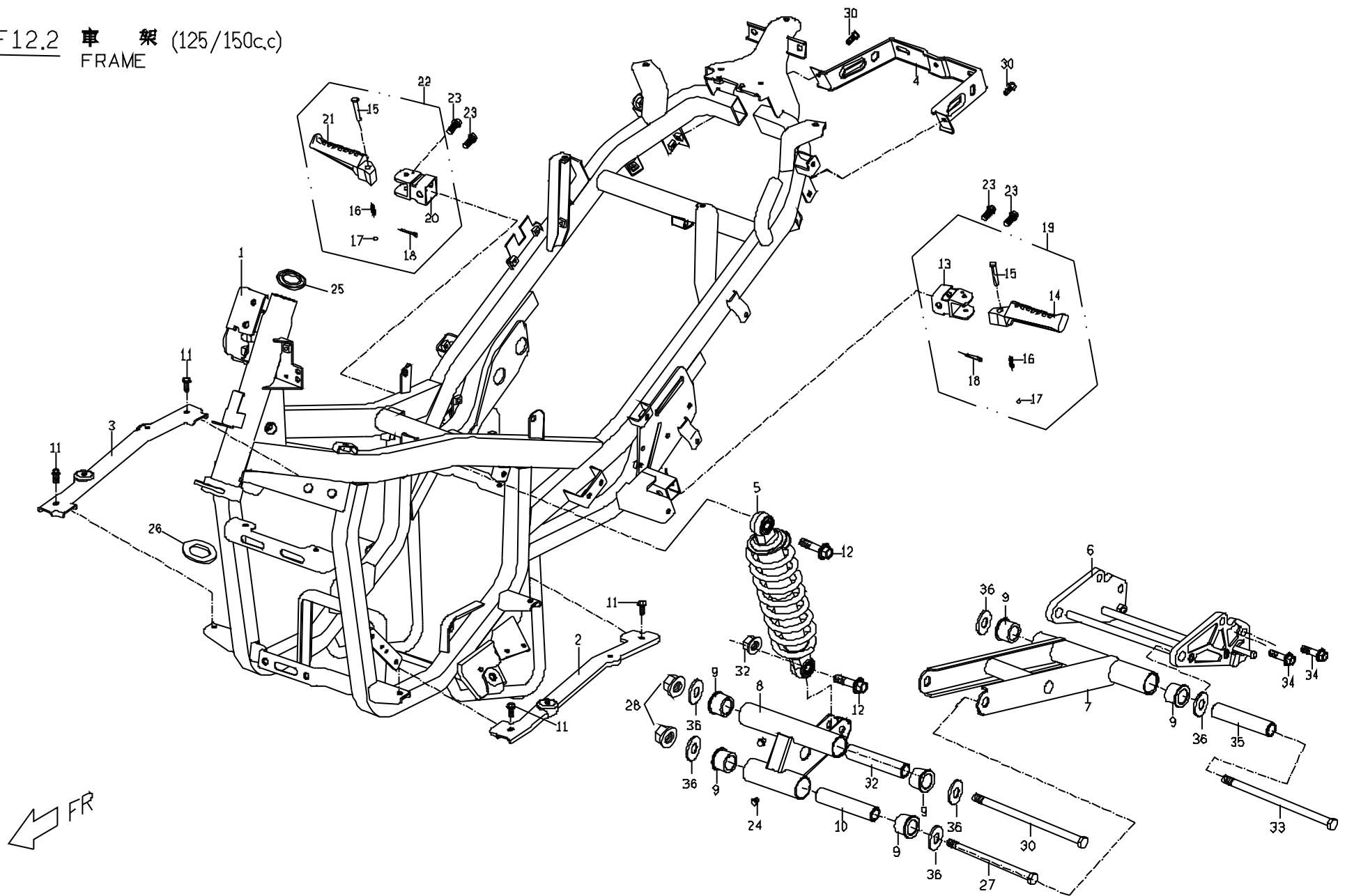

F12.2 車架 / FRAME M2-125/M2-150

available for M2-125/150

No.	Part No.	Q'TY	PART NAME	PART NAME	REMARK
項目	零件號碼	數量	零件中文名稱	零件英文名稱	備註
1	M2421002600	1	車架總成(ED)	FRAME ASSY (W/O SIDE-STAND SENSOR)	M2-125/M2-150
1	M242A0026002	1	車架總成(ED)	FRAME ASSY (W/H SIDE-STAND SENSOR)	M2-125/M2-150有側柱開關
2	M2421420000	1	腳踏板支撐板(左)	SUPPORTING HOLDER ,STEPFLOOR(LH)	
3	M242A420000	1	腳踏板支撐板(右)	SUPPORTING HOLDER ,STEPFLOOR(RH)	
4	M2421410000	1	牌照板連接板	LICENCE PLATE , LINK PLATE	
5	M2481001000	1	後緩衝器總成 125/150	CUSHION ASSY, RR	M2-125/M2-150
6	M2451031600	1	引擎下固定架	ENGINE HANGER, LOWER	M2-125/M2-150
7	M2451021600	1	拉桿	PULL LINKAGE	M2-125/M2-150
8	M2451011600	1	三角搖臂	TRIANGLE SWING ARM	M2-125/M2-150
9	X0481130000	6	後軸拖架襯套	BUSH,RR AXLE BRACKET	
10	M2451050000	1	搖臂間隔管B	SPACER TUBE B	
11	90190601500	1	六角凸緣螺栓(M6*15L)	HEXAGON FLANGE BOLT (M6*15L)	
12	90191004000	2	六角凸緣螺栓(M10*1.25P*40L)	HEXAGON FLANGE BOLT (M10*1.25P*40L)	
13	M2463020000	1	後座腳踏桿組合(左)	BACKSEAT PEDAL LEVER COMP (L)	
14	E1463020000	1	左腳踏桿	PEDAL LEVER, LH	
15	E1463040000	2	固定銷	LOCK PIN	
16	E1463050000	2	壓縮彈簧	SPRING	
17	99010600000	2	鋼珠(1/4")	BEARING BALL(1/4")	
18	93520201200	2	開口銷	COTTER PIN	
19	M2463020000	1	後座腳踏桿組合(左)	BACKSEAT PEDAL LEVER COMP (L)	
20	M2464020000	1	後座腳踏桿組合(右)	BACKSEAT PEDAL LEVER COMP (R)	
21	E1464020000	1	右腳踏桿	PEDAL LEVER, RH	
22	M2464020000	1	後座腳踏桿組合(右)	BACKSEAT PEDAL LEVER COMP (R)	
23	90190604001	4	六角凸緣螺栓	HEXAGON FLANGE BOLT (M6*40L)	
24	X0481070000	3	注油閥	GREASE FILLING NUT	
25	C1443020000	1	上軸承座	UPPER BEARING CAGE	
26	C1443011000	1	軸承底座	LOWER BEARING CAGE	
27	90191412500	1	六角凸緣螺栓(M14*1.5P*125L)	EXAGON FLANGE BOLT	
28	92061400000	2	凸緣U型防鬆螺帽	LOCK NUT,FLANGE U TYPE	
29	M24510700001	2	自潤軸襯	AUTOMATIC OILING BUSH	

F12.2 車架 (125/150c.c)
FRAME

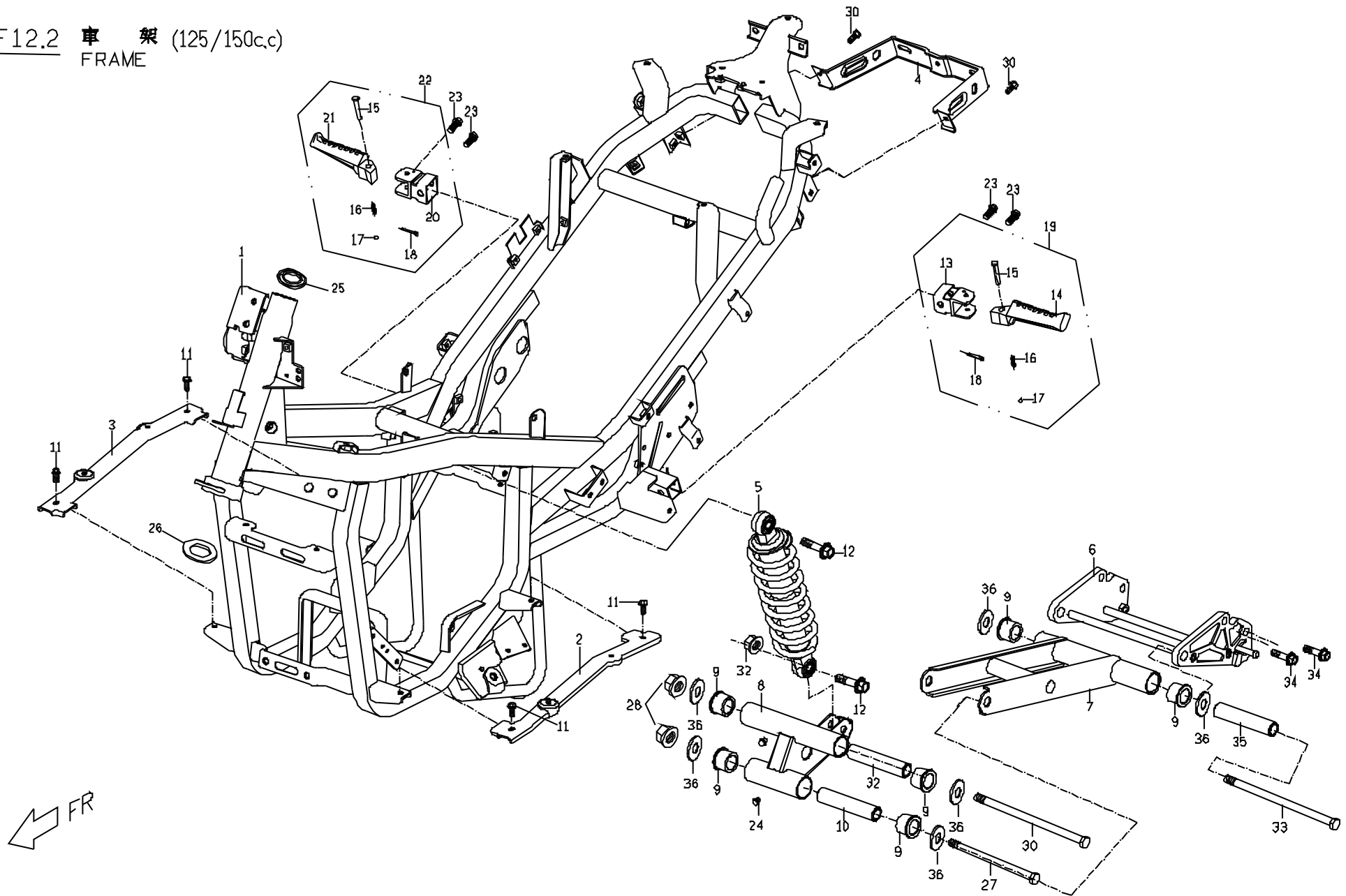

F12.2 車架 / FRAME M2-125/M2-150**available for M2-125/150**

No.	Part No.	Q'TY	PART NAME	PART NAME	REMARK
項目	零件號碼	數量	零件中文名稱	零件英文名稱	備註
30	90190601500	2	六角凸緣螺栓(M6*15L)	HEXAGON FLANGE BOLT (M6*15L)	
31	90191420500	1	六角凸緣螺栓(M14*1.5P*205L)	EXAGON FLANGE BOLT	
32	M2451040000	1	搖臂間隔管A	SPACER TUBE A	
33	90191422000	1	六角凸緣螺栓	EXAGON FLANGE BOLT	M2-125/M2-150
34	90191002000	4	六角凸緣螺栓	EXAGON FLANGE BOLT	M2-125/M2-150
35	M2451060000	1	搖臂間隔管C	SPACER TUBE C	M2-125/M2-150
36	X0481140000	6	防塵蓋	DUSTPROOF	

F13 燃料箱
FUEL TANK

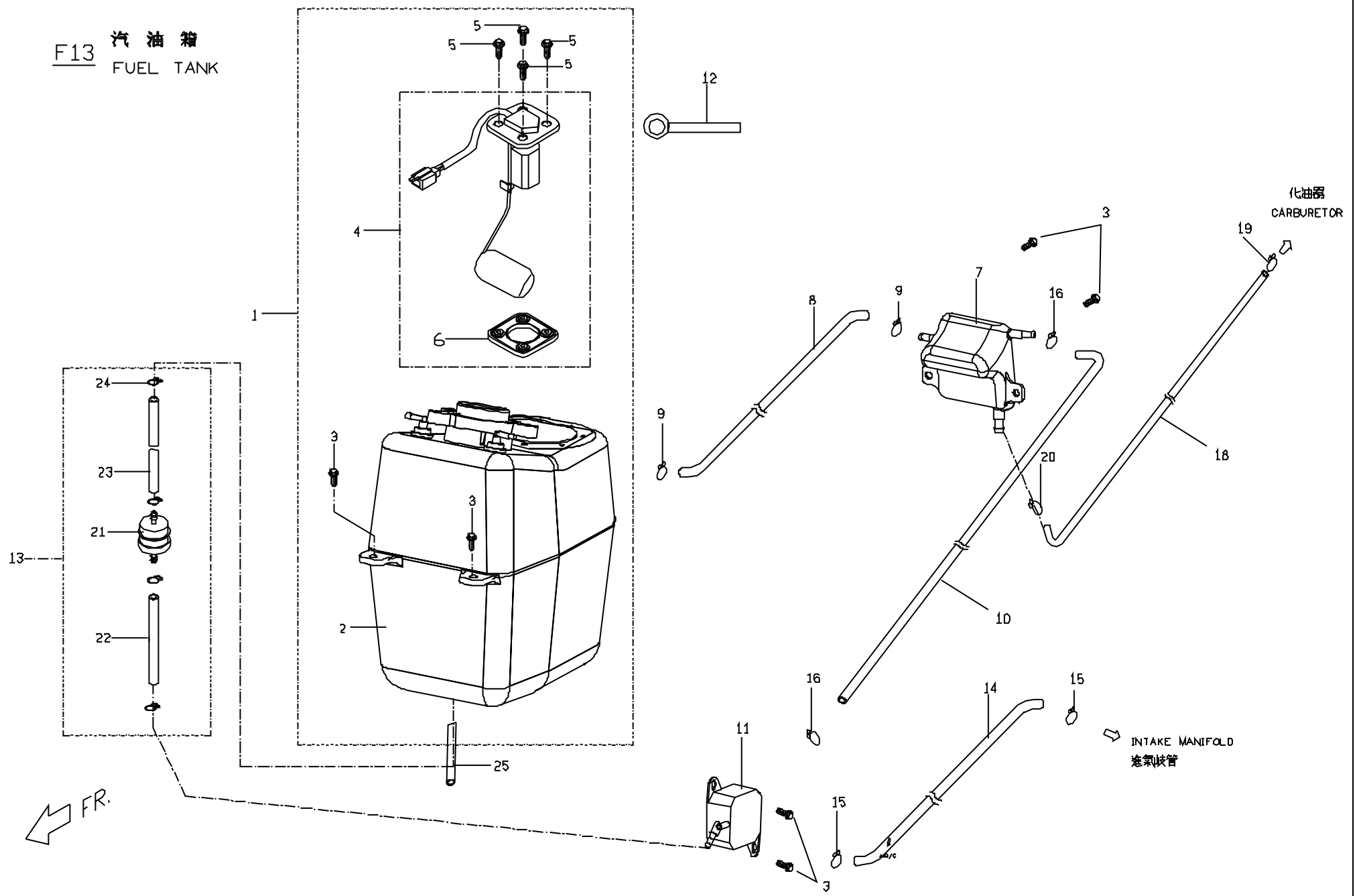

F13 汽油箱 / FUEL TANK

No.	Part No.	Q'TY	PART NAME	PART NAME	REMARK
項目	零件號碼	數量	零件中文名稱	零件英文名稱	備註
2	ACCORDING BOM	1	汽油箱	FUEL TANK	OPTIONAL PART
2	M2521500000	1	汽油箱(有EEC)	FUEL TANK(W/H EEC)	W/H EEC
3	90190601500	7	六角凸緣螺栓(M6*15L)	HEXAGON FLANGE BOLT (M6*15L)	
4	M2521700000	1	汽油量計組合	FUEL GUAGE COMP.	
5	90200501400	4	六角凸緣螺栓	HEXAGON FLANGE BOLT	
6	C152A090000	1	止油墊圈	PACKING, FUL GAUGE	
7	M2521600000	1	副汽油箱	AD.FUEL TANK	
8	M2526040000	1	回油管(副汽油箱到汽油箱)	BACK FUEL HOSE(AD TANK TO TANK)	
9	922213000001	2	板狀管夾	HOSE CLAMP	
10	M25260200001	1	汽油管(汽油泵浦至副汽油箱)	FUEL HOSE(PUMP TO AD. TANK)	M2-50
10	M2526020000	1	汽油管(汽油泵浦至副汽油箱)	FUEL HOSE(PUMP TO AD. TANK)	M2-125/150
11	M25218000001	1	汽油泵浦	FUEL PUMP COMP	M2-50
11	M2521800000	1	汽油泵浦	FUEL PUMP COMP	M2-125/150
12	ES706020000	1	導線夾	WIRE CLIP	
13	M25212000001	1	汽油濾清器總成	FUEL FILTER ASSY	M2-50
13	M2521200000	1	汽油濾清器總成	FUEL FILTER ASSY	M2-125/150
14	M25260100001	1	背壓管(汽油泵浦至進氣歧管)	VACUUM HOSE(PUMP TO INTAKE MANIFOLD)	M2-50
14	M2286260000	1	背壓管(汽油泵浦至進氣歧管)	VACUUM HOSE(PUMP TO INTAKE MANIFOLD)	M2-125/150,W/H SAI
14	M2526010000	1	背壓管(汽油泵浦至進氣歧管)	VACUUM HOSE(PUMP TO INTAKE MANIFOLD)	M2-125/150,W/O SAI
15	E1706110000	2	管束	PIPE CLIP	
16	E1706110000	2	管束	PIPE CLIP	
18	M25260300001	1	汽油管(副汽油箱到化油器)	FUEL HOSE(AD. TANK TO CARBURETOR)	M2-50
18	M2526031000	1	汽油管(副汽油箱到化油器)	FUEL HOSE(AD. TANK TO CARBURETOR)	M2-125/150
19	E1706110000	2	管束	PIPE CLIP	
20	92211200001	1	軟管夾	HOSE CLAMP	
21	P65212100001	1	汽油濾清器	FUEL FILTER	
22	M252A010000	1	汽油管	FUEL PIPE(FILTER TO PUMP)	
23	M252A020000	1	汽油管	FUEL PIPE(TANK TO FILTER)	
24	M252A030000	4	板狀管夾	HOSE CLAMP	
25	M2521220000	1	油網	COARSE FUEL FILTER	

F14.2 中腳柱/側腳柱 / CENTER STAND,SIDE STAND M2-125/M2-150

AVAILABLE FOR M2-125/M2-150

No.	Part No.	Q'TY	PART NAME	PART NAME	REMARK
項目	零件號碼	數量	零件中文名稱	零件英文名稱	備註
1	M2461001600	1	中腳柱組合	CENTER STAND COMP	
2	C1701050000	1	緩衝橡膠	CUSHION RUBBER	
3	E1461121000	1	彈簧	CENTER STAND SPRING	
4	90191003500	1	六角凸緣螺栓(M10*1.25P*28L)	HEXAGON FLANGE BOLT (M10*1.25P	
5	C2461010000	2	襯套	BUSH	
6	M2462001600	1	側腳柱總成(黑色E.D)	SIDE STAND	
7	92061000001	1	凸緣U型螺帽(M10*1.25P)	U TYPE FLANGE NUT(M10*1.25P)	
8	C2462120000	1	側腳柱彈簧	SPRING,SIDE STAND	
9	M2486001000	1	引擎吊架本體熔接組合	ENGINE HANGER ASSY.	
10	90191018000	1	六角凸緣螺栓	HEXAGON FLANGE BOLT	
11	92061000001	1	凸緣U型螺帽(M10*1.25P)	U TYPE FLANGE NUT(M10*1.25P)	
12	M2486070000	2	防震橡膠結合管	RUBBER,DAMPER	
13	C14860500001	1	緩衝襯套	CUSHION RUBBER	
14	M2486010000	2	六角凸緣螺栓	HEXAGON FLANGE BOLT	

F15.2 主配線 M2-125/150
WIRE HARNESS

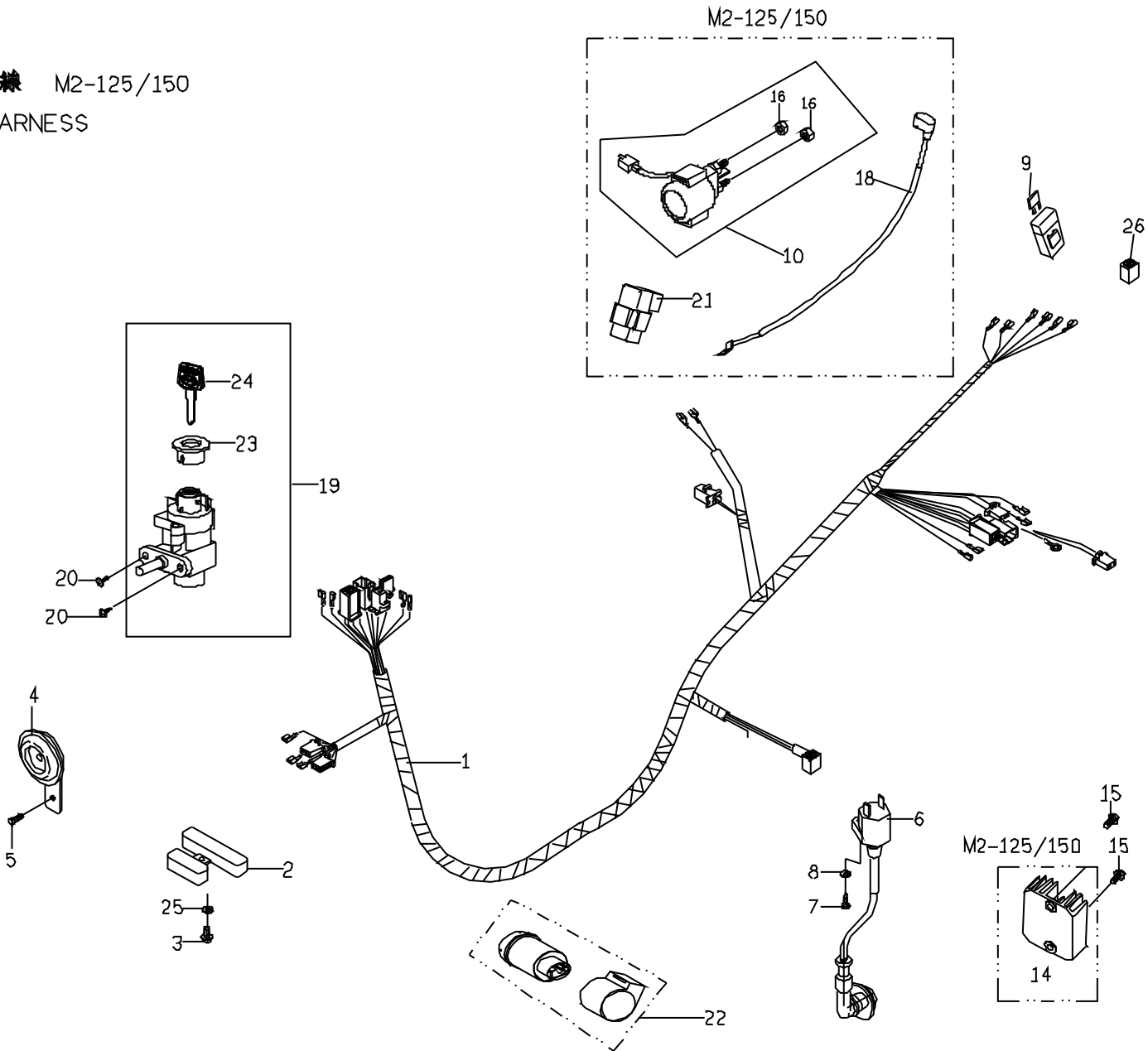
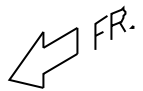

F15.2 主配線 / WIRE HARNESS (M2-125/M2-150)**AVAILABLE FOR M2-125/M2-150 MODEL**

No.	Part No.	Q'TY	PART NAME	PART NAME	REMARK
項目	零件號碼	數量	零件中文名稱	零件英文名稱	備註
1	M2581601000	1	主配線	WIRE HARNESS , MAIN	M2-125/M2-150
2	ES586600000	1	電阻器	RESISTOR	DC LIGHTING
3	90190601500	2	六角凸緣螺栓(M6*15L)	HEXAGON FLANGE BOLT (M6*15L)	
4	B5583600000	1	喇叭	HORN	M2-125/M2-150
5	90190801200	1	六角凸緣螺栓(M8*12L)	HEXAGON FLANGE BOLT (M8*12L)	
6	M2584600000	1	點火線圈總成	COIL COMP(M2-50)	M2-125/M2-150
7	90070502000	1	十字槽扁圓頭機器螺釘(M5*20L)	CR TRUSS HD MACHINE SCREW(M5*20L)	
8	92110500000	1	彈簧鎖緊墊圈	SPRING LOCK WASHER	
9	98701215000	1	保險絲	FUSE, 15A	M2-125/M2-150
11	P1701190000	1	橡膠托架	RUBBER BRACKET	
12	C1582001000	1	電子點火控制器總成	CDI UNIT ASSY.	M2-125/M2-150
10	C1581001000	1	起動繼電器總成	STARTER RELAY	M2-125/M2-150
14	C2584000000	1	電壓調整器總成	VOL REGULATOR COMP.	DC LIGHTING
15	90190601500	1	六角凸緣螺栓(M6*15L)	HEXAGON FLANGE BOLT (M6*15L)	
16	92030600004	2	六角螺帽	HEXAGON NUT	M2-125/M2-150
18	M2583020000	1	電瓶正極線	BATTERY (+)LINE	M2-125/M2-150
19	M2552000000	1	電源鎖總成	IGNITION SWITCH COMP.	
20	90040602003	2	十字槽盤頭機器螺釘	CR TRUSS HD MACHINE SCREW	
21	C1582500000	1	頭燈控制器	HEADLAMP CONTROLLER	DC LIGHTING
22	P2586011000	1	方向繼電器總成	FLASHER RELAY ASSY	
23	M255B010000	1	紙示蓋組合	KEY INDICATOR ASSY	
24	ES55B010000	1	空白鑰匙	DUMMY KEY	
25	92130600000	1	齒形墊圈(0.6T)	TEETH TYPE WASHER	
26	C158A010000	1	二極體組合	DIODE ASSY.	
27	C2581620000	1	側腳柱安全開關	SAFETY SENSOR, SIDE STAND	OPTIONAL PART
28	90040501600	2	十字槽盤頭機器螺釘	CR TRUSS HD MACHINE SCREW	OPTIONAL PART
29	M2581610000	1	頭燈恆亮截接線	CONNECTING WIRE, HEADLAMP	OPTIONAL PART

F16. LABEL



1



2



3



4



5



6



7



8



9



10

11



12



13

F17 燃料蒸發E.C.控制系統
 E.E.C SYSTEM (OPTIONAL DEVICE)

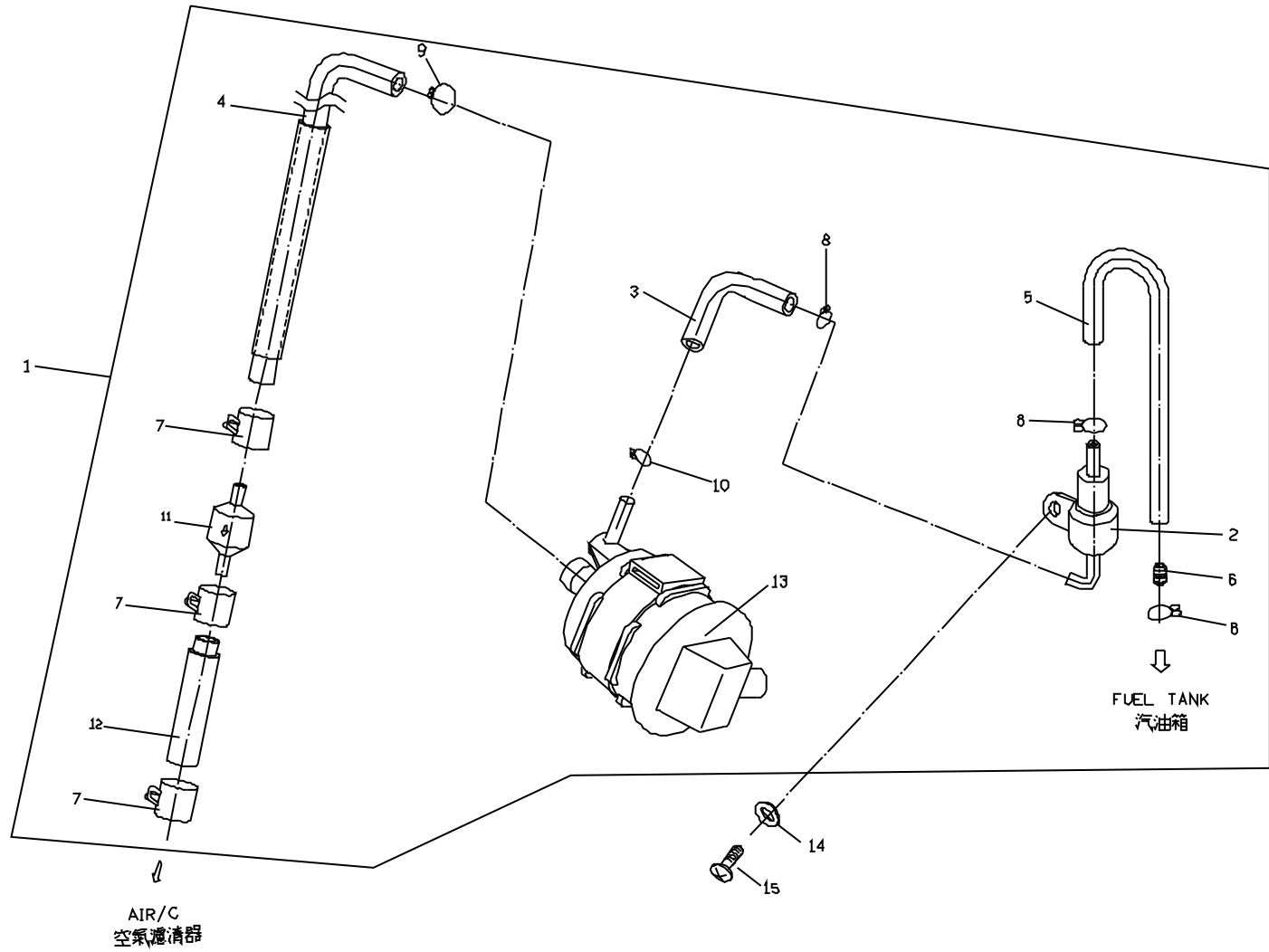

比雅久零件材料中心

項次	服務站	電話	住 址	項次	服務站	電話	住 址
1	摩特動力	04-8528111	彰化縣員林鎮山腳路66號	26	UCC	04-8392268	彰化縣員林鎮新生路129號
2	雅歐車業	04-8314020	彰化縣員林鎮山腳路三段45號	27	精宏	04-8535139	彰化市大村鄉中山路二段244號
3	良力	02-22489480	台北縣中和市景平路684號	28	正全	04-8961539	彰化縣二林鎮大成路一段372號
4	正富	02-23077077	台北市西園路二段233號	29	丞宇行	04-92318867	草屯鎮成功路一段142號
5	世群	02-23752251	台北市和平西路二段147號	30	谷泰	04-92915757	南投縣埔里鎮中山路3段523號
6	宏聖	02-22551229	板橋市文聖街89巷27號	31	名富	05-2060671	嘉義縣民雄鄉西安路46號
7	全勝	02-24232826	基隆市南榮路125號	32	昇達	05-2279820	嘉義市公明路304號
8	賢旻	02-27423399	台北市八德路4段303號	33	加盛	05-2315375	嘉義市自由路265號
9	安輝	02-27827800	台北市南港區南港路3段145號	34	吉祥	05-2535701	嘉義縣中埔鄉十字路125號
10	大大	02-27865261	台北市南港路二段117號	35	東鑫	05-5321871	雲林縣斗六市鎮北路250之1號
11	騰王	02-28575426	台北縣三重市仁愛街705號	36	佳輝	06-2131211	台南市永福路一段76號
12	三鑫	02-29255022	台北縣永和市豫溪街48號	37	良心	06-2824072	台南市小北路100號
13	金重	02-29854124	台北縣三重市重陽路四段146號	38	俊華	06-5981253	台南縣新化鎮大智路17號
14	翔富	03-3325786	桃園市民生路418號	39	上暉	06-6225038	台南縣柳營鄉十美街387號
15	信安行	03-3668500	桃園市昆明路122號	40	億豐	06-7227102	台南縣佳里鎮成功路53之6號
16	正暉	03-3783526	桃園縣八德市永豐路517號	41	寶獅	06-9262127	澎湖縣馬公市中華路246號
17	尚達	03-4223832	桃園縣中壢市延平路298號	42	政大	07-3213366	高雄市撫順街138號
18	信益	03-5254624	新竹市中山路314號	43	瑾慶	07-5311218	高雄市鼓山區九如四路902號
19	冠昇	037-356660	苗栗市中正路1032號	44	偉成	07-6971065	高雄縣路竹鄉大社路107號
20	東霸	03-8333969	花蓮市中正路120號	45	慶忠	07-7433937	高雄縣鳳山市自由路96之3號
21	泓號	03-9651858	宜蘭縣五結鄉中正路二段141號	46	永達	08-2325039	金門縣金城鎮民族路21-1號
22	豐群	04-22916766	台中市北區山西路二段135號	47	安荃	08-7329388	屏東市忠孝路126之1號
23	比大輪	04-25122288	台中縣豐原市向陽路272號	48	鴻利	08-8328466	屏東縣東港鎮中山路6號
24	金享	04-25662906	台中縣大雅鄉民興街153號				
25	申璋	04-26631750	台中縣沙鹿鎮中山路477之9號				

PGO

比能久機車

地址：彰化縣大村鄉山腳路66號

TEL:04-8528111 FAX:04-8528112



台灣農林股份有限公司 代理銷售

摩特動力工業股份有限公司 榮譽出品

M2353000000