

## PA50/100/125COLOR CODE (可動 / MOVABLE MODEL)

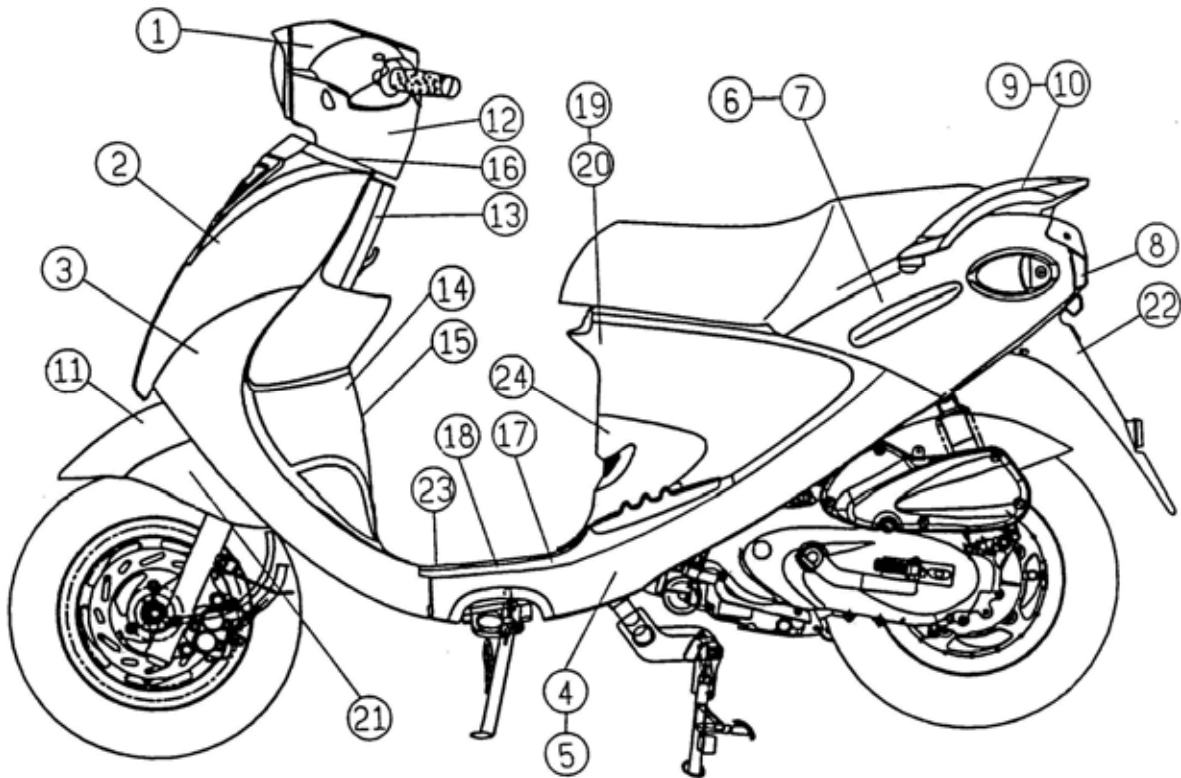

### PA50/100/125:外觀塗裝件件號(ABS件)

Name/Color	SILVER-BLACK(D6)	BLUE	BLACK
1. HANDLE UPPER COVER	P5613000690	P56130004T0	P5613000690
2. WINDSHIELD	P6621000690	P66210004T0	P6621000690
3. FRT LOWER COVER	P5626013690	P56260134T0	P5626013690
4. LH SIDE COVER	P66263007J0	P66263007J0	P66263007J0
5. RH SIDE COVER	P66265007J0	P66265007J0	P66265007J0
6. LH BODY COVER	P6625301690	P66253014T0	P6625301690
7. RH BODY COVER	P6625501690	P66255014T0	P6625501690
8. REAR COVER	P6625700690	P66257004T0	P6625700690
9. RR LUGGAGE BRACET	P66760007J0	P66760007J0	P66760007J0
10. RR LUGGAGE COVER	P6676010000	P6676010000	P6676010000
11.2. FRT SECTION,FRT FENDER(PA125)	P6632000690	P66320004T0	P6632000690

### PA50/100/125:外觀塗裝件件號(PP件)

Name/Color	BLACK	REMARK
12. HANDLE LOWER COVER	P5614000650	
13. UPPER SECTION,INNER COVER	P5623030650	
14. LOWER SECTION, INNER COVER	P5623040650	
15. VIN COVER	P5623010650	
16.FRT PANET,INNER COVER	P5623020650	
17. STEPFLOOR	P6624001650	
18. BATTERY COVER	C2624031650	
19.BODY COVER,LH FRT	P662E010650	
20. BODY COVER,RH FRT	P662E020650	
21.2.RR SECTION, FRT FENDER(PA125)	C2632600650	
22. LICENCE PLATE	P5636003650	
23. MAT FLOOR	P6624501000	
24. MIDDLE COVER	P6625010650	

# E1 CRANK CASE

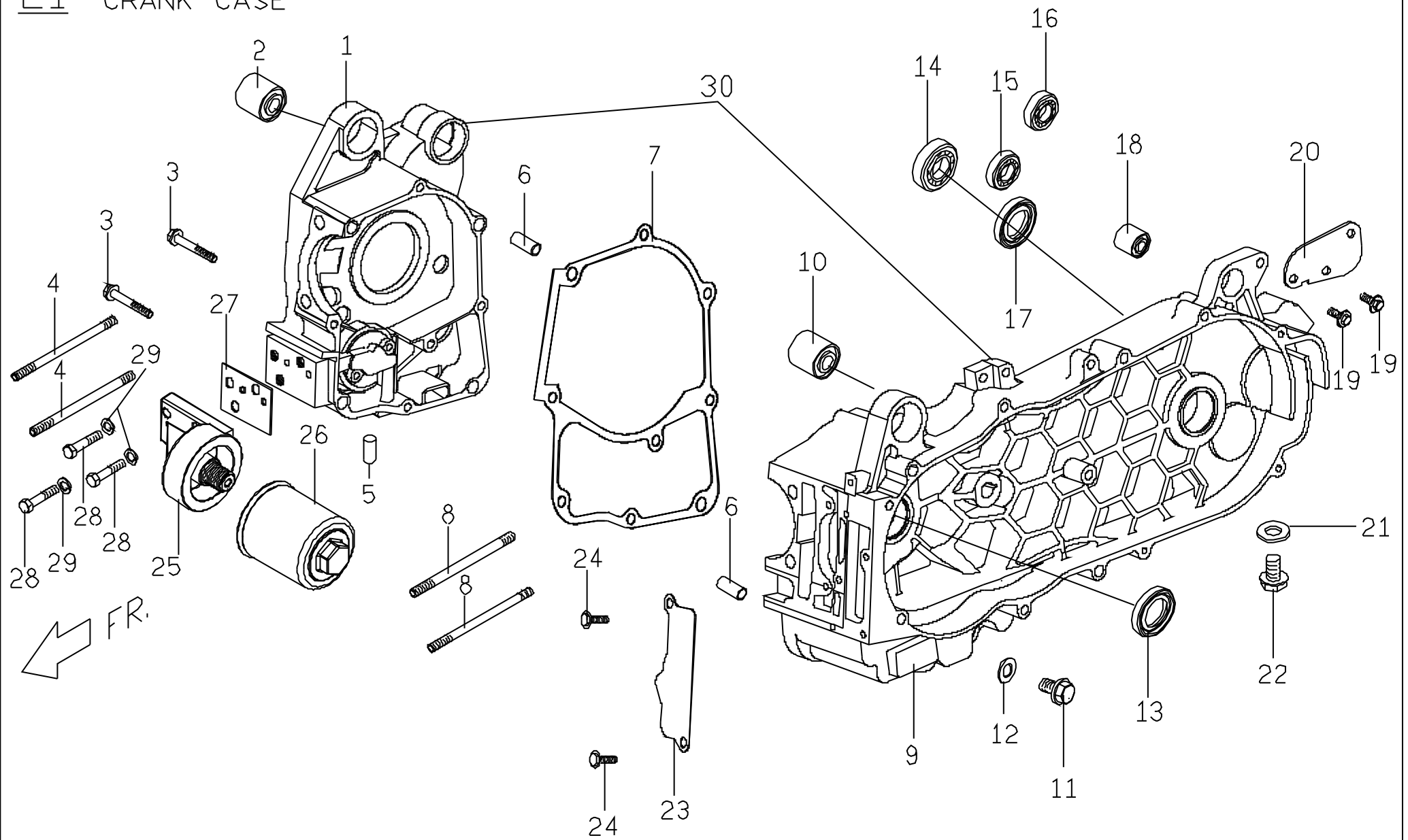

## E1. PA125\_CRANKCASE

No.	Part No.	Q'TY	PART NAME	PART NAME	REMARK
項目	零件號碼	數量	零件中文名稱	零件英文名稱	備註
1	C1061012000	1	右曲軸箱	RH CRANKCASE	
2	E1061020000	1	防震襯套	RUBBER BUSH	
3	90190605003	2	六角凸緣螺栓(M6*50L)	HEXAGON FLANGE BOLT	
4	90170818800	2	雙頭螺絲	STUP BOLT	
5	G1061070000	2	油塞	PLUG OIL	
6	93540801400	2	定位銷	LOCK PIN	
7	C5061040000	1	曲軸箱墊片	CRANKCASE GASKET	
8	90170819500	2	雙頭螺絲	STUD BOLT	
9	C2062012000	1	左曲軸箱	LH.CRANKCASE	
10	E1061020000	1	防震襯套	RUBBER BUSH	
11	90181201500	1	六角凸緣螺栓	HEXAGON FLANGE BOLT	
12	92141200006	1	平墊圈	PLAIN WASHER	
13	95572232601	1	TC形油封(φ 32*φ 20.9*6t)	OIL SEAL TC TYPE	
14	96510620402	1	深槽滾珠軸承(6204)	DEEP GROOVE BALL BEARING	
15	96510620200	1	深槽滾珠軸承(6202)	DEEP GROOVE BALL BEARING	
16	96510620301	1	深槽滾珠軸承(6203)	DEEP GROOVE BALL BEARING	
17	95572032600	1	TC形油封(φ 32*φ 19.5*6t)	OIL SEAL TC TYPE	
18	P1062020000	1	防震襯套	RUBBER BUSH	
19	90190601601	2	六角凸緣螺栓(M6*16L)	HEXAGON FLANGE BOLT	
20	C2706010000	1	空氣濾清器固定板	FIXING PLATE, AIR CLEANER	
21	92140800001	1	平墊圈	PLAIN WASHER	
22	90190801200	1	六角凸緣螺栓(M8*12L)	HEXAGON FLANGE BOLT	
23	C1286320000	1	空氣進氣蓋隔板	SEP PLAT,SECOND AIR COVER	
24	90190602700	2	六角凸緣螺栓(M6*27L)	HEXAGON FLANGE BOLT	
25	C1082030000	1	機油濾清器固定座	SEAT, OIL FILTER	
26	C1082020000	1	機油濾清器	OIL FILTER	
27	C1082041000	1	機油濾清器墊片	GASKET, OIL FILTER	



# E2 LH SIDE COVER

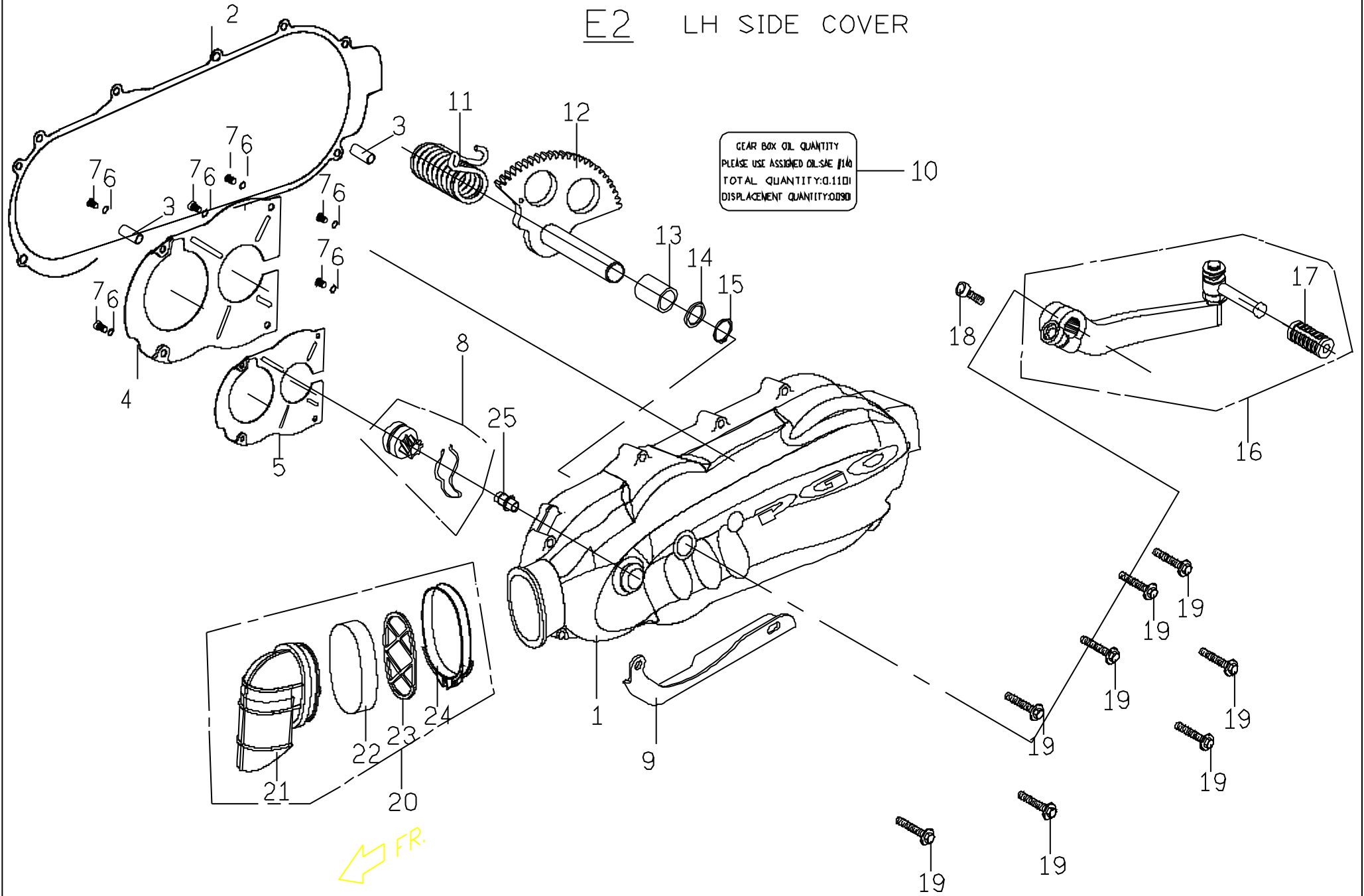

## E2. PA125\_LH SIDE COVER

No.	Part No.	Q'TY	PART NAME	PART NAME	REMARK
項目	零件號碼	數量	零件中文名稱	零件英文名稱	備註
1	C20630127202	1	左邊蓋(散銀)	LH SIDE COVER	
2	C2063020000	1	左邊蓋襯墊	GASKET LEFT COVER	
3	93540801400	2	定位銷	LOCK PIN	
4	C20630600001	1	隔板	PARTITION PLATE	
5	C20631200001	1	隔板襯墊	PACKING, PARTITION PLATE	
6	92110500000	6	彈簧鎖緊墊圈	SPRING WASHER	
7	90050500900	6	十字圓頭機器螺釘	C-R ROUND HD. TAPPING SCREW	
8	C1251001000	1	腳踏被動齒輪彈簧組合	DRIVEN GEAR & SPG. ASSY.	
9	C1062081000	1	中腳柱止擋托架	BRACKET, CENTER STAND	
10	C16031400001	1	齒輪油注意貼紙	GEAR OIL NOTICE LABEL	
11	C1251111000	1	扭轉彈簧	TORSION SPRING	
12	C1251101000	1	腳踏起動心軸組合	KICK,SHAFT ASSY	
13	C1251120000	1	襯套	BUSH,KICK SPINPLE	
14	92141700002	1	平墊圈	PLAIN WASHER	
15	92171700000	1	C型扣環	RETAINING RING C-TYPE	
16	C1251200000	1	起動踏桿組合	ARM,KICK STARTER ASSY	
17	E1251240000	1	起動板膠套	RUBBER,PAD,KICK STARTER	
18	90210802500	1	六角角承窩螺栓	HEXAGON SOCKET HEAD CAP BOLT	
19	90190604001	8	六角凸緣螺栓	HEXAGON FLANGE BOLT	
20	C1063102000	1	通風管組合	BREATHER PIPE COMP	
21	C1063030000	1	通風管	BREATHER PIPE	Not supplied
22	C1063092000	1	過濾棉	SPONGE,BREATHER PIPE	
23	C1063110000	1	固定板	FIXING PLATE	
24	C1706280000	1	管夾	CLAMP	
25	C1251171000	1	起動固定心軸	START FIXED SHAFT	



## E3. PA125\_CYLINDER HEAD

No.	Part No.	Q'TY	PART NAME	PART NAME	REMARK
項目	零件號碼	數量	零件中文名稱	零件英文名稱	備註
1	C10710120001	1	汽缸頭	HEAD COMP. CYLINDER	
5	C1071200000	1	排氣閥	VALVE EXHAUST	
6	C1071300000	1	進氣閥	VALVE INLET	
7	C1071072000	1	汽缸頭墊片	GASKET HEAD CYL.	
8	93541001401	2	定位銷 (10*14)	LOCK PIN	
9	90190610000	2	六角凸緣螺栓	HEXAGON FLANGE BOLT	
10	90170802900	2	雙頭螺栓	STUD BOLT	
11	90170606300	2	雙頭螺栓	STUD BOLT	
12	C1261320000	1	化油器絕緣板墊片	INSULATOR CARB GASKET	
13	C1261310000	1	化油器絕緣板	INSULATOR CARB	
14	C1261052000	1	進氣歧管組合	INTAKE MANIFOLD COMP	
15	95512700001	1	O形環	O RING	
16	90150400800	4	十字槽扁圓頭自攻螺釘	C-R TAPPING MACHINE SCREW	
17	C1261061000	1	管束	HOSE CLAMP	
18	92040600000	2	六角凸緣螺帽 (M6*1.0P)	HEXAGON FLANGE NUT	
19	C1222000000	1	火星塞(NGK C7HAS)	IGNITION PLUG	
20	92431600002	2	平墊圈	PLAIN WASHER	
21	C1071410000	2	閥門彈簧	SPRING, VALVE	
22	C1071440000	2	閥門彈簧承盤	RETAIER VALVE SPRING	
23	C1071430000	4	閥門栓	COTTER VALVE	
24	C1073001000	1	凸輪軸總成	CAM,SHAFT ASSY.	
25	C1072060000	1	排氣閥搖臂軸	SHAFT,EX.ROCKER ARM	



曲軸及汽缸 (100/125 CC)

E4. CYLINDER . PISTON . CRANKSHAFT

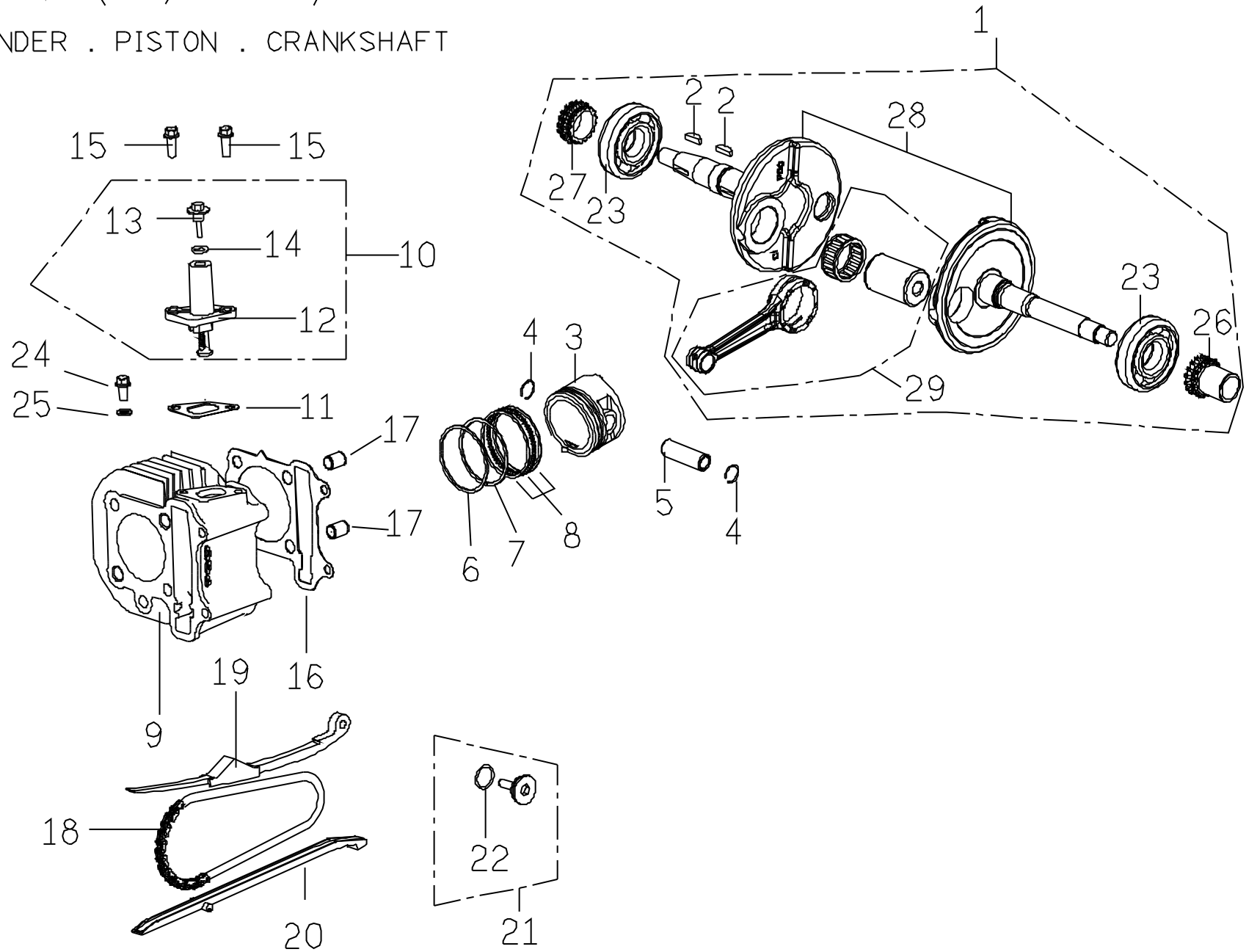

## E4. PA125\_CRANKSHAFT

No.	Part No.	Q'TY	PART NAME	PART NAME	REMARK
項目	零件號碼	數量	零件中文名稱	零件英文名稱	備註
1	C1066503000	1	曲柄軸總成	CRANKSHAFT COMP.	
2	93530402500	2	半月鍵	WOODRUFF KEY	
3	C1067013000	1	活塞	PISTON	
4	C1067150000	2	活塞銷夾	CLIP,PISTON PIN	
5	C1067110000	1	活塞銷	PISTON PIN	
6	C10673100001	1	活塞環(1)"R1"	PISTON RING (1)	
7	C1067321000	1	活塞環(2)"RN"	PISTON RING (2)	
8	C1067402000	1	刮油環組合	OIL SCRAPER RING COMP	
9	C1064011000	1	汽缸	CYLINDER	
10	C1072500000	1	鏈條調整器組合	CHAIN ADJUSTER COMP.	
11	C1072480000	1	鏈條調整器墊片	GASKET,CHAIN ADJUSTER	
13	C1072560000	1	鍊條調整器螺栓	CHAIN ADJUSTER BOLT	
14	95510900001	1	O形環	O RING	
15	90190601601	1	六角凸緣螺栓	HEXAGON FLANGE BOLT	
16	C1064110000	1	汽缸墊片	GASKET CYLINDER	
17	93541001401	2	定位銷 (10*14)	LOCK PIN	
18	C1072460000	1	凸輪軸鏈條	CHAIN,CAMSHAFT	
19	C1072440000	1	鏈條拉力桿	TENSIONER,CAM CHAIN	
20	C1072470000	1	鏈條導件	GUIDE COMP,CAM CHAIN	
21	C1072490000	1	拉力桿螺絲組合	PIVOT,CAM CHAIN TENSION	
22	95511500001	1	O型環	O RING	
23	C1062100000	2	滾珠軸承 (特殊)	ROLLER BEARING	
24	90190601200	1	六角凸緣螺栓 (M6*1.0P*12)	HEXAGON FLANGE BOLT	
25	92140600011	1	平墊圈	PLAIN WASHER	
26	C1066130000	1	正時鍊輪	TIMING SPROCKET	
27	C1066140000	1	機油泵鍊輪	OIL PUMP SPROCKET	
28	C106F010000	1	左右曲軸組合	LH & RH CRANKSHAFT ASSY.	
29	C106F020000	1	連桿組合	CONNECTING ROD ASSY.	

E5 RIGHT CRANKCASE COVER

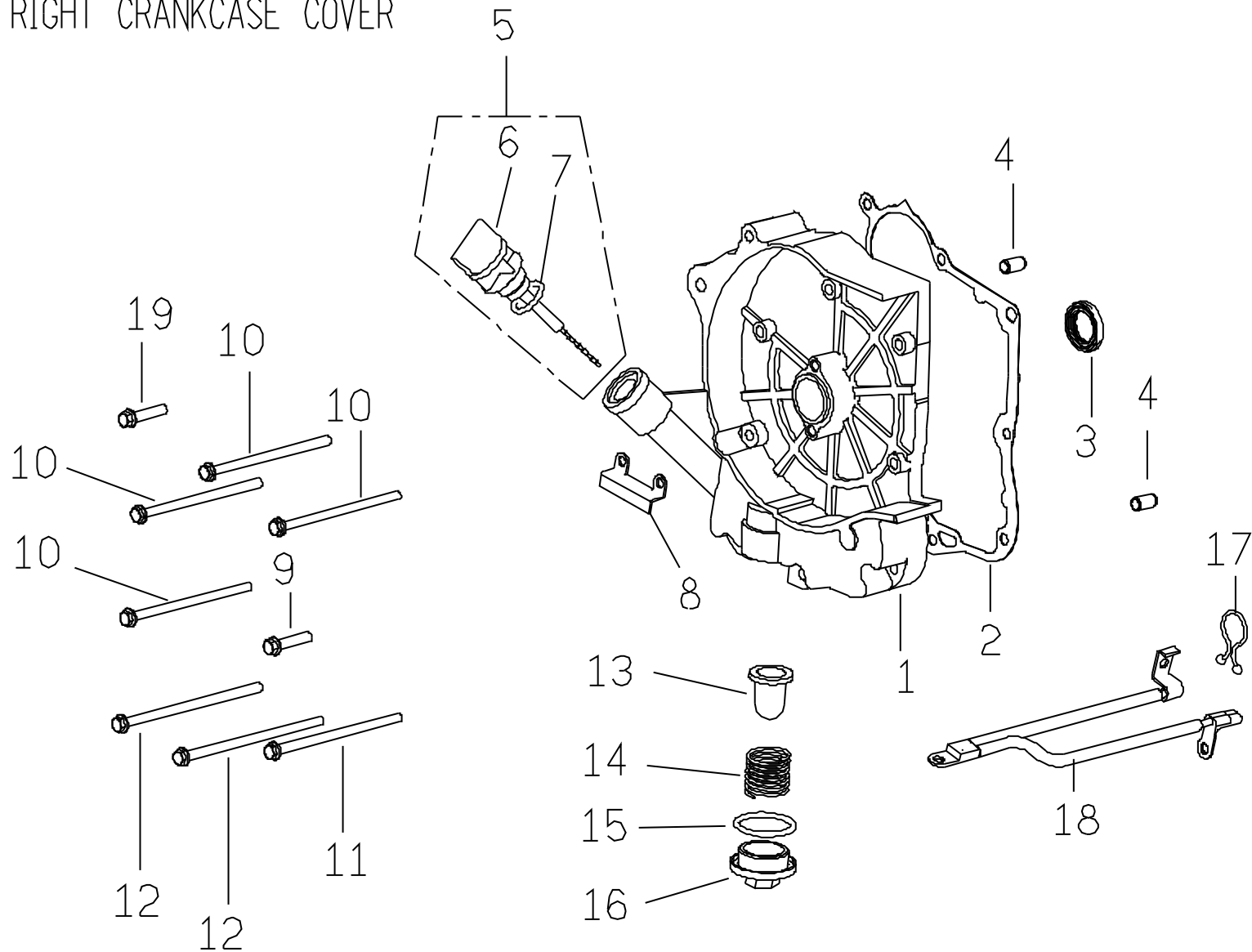



E6. 化油器  
CARBURETOR

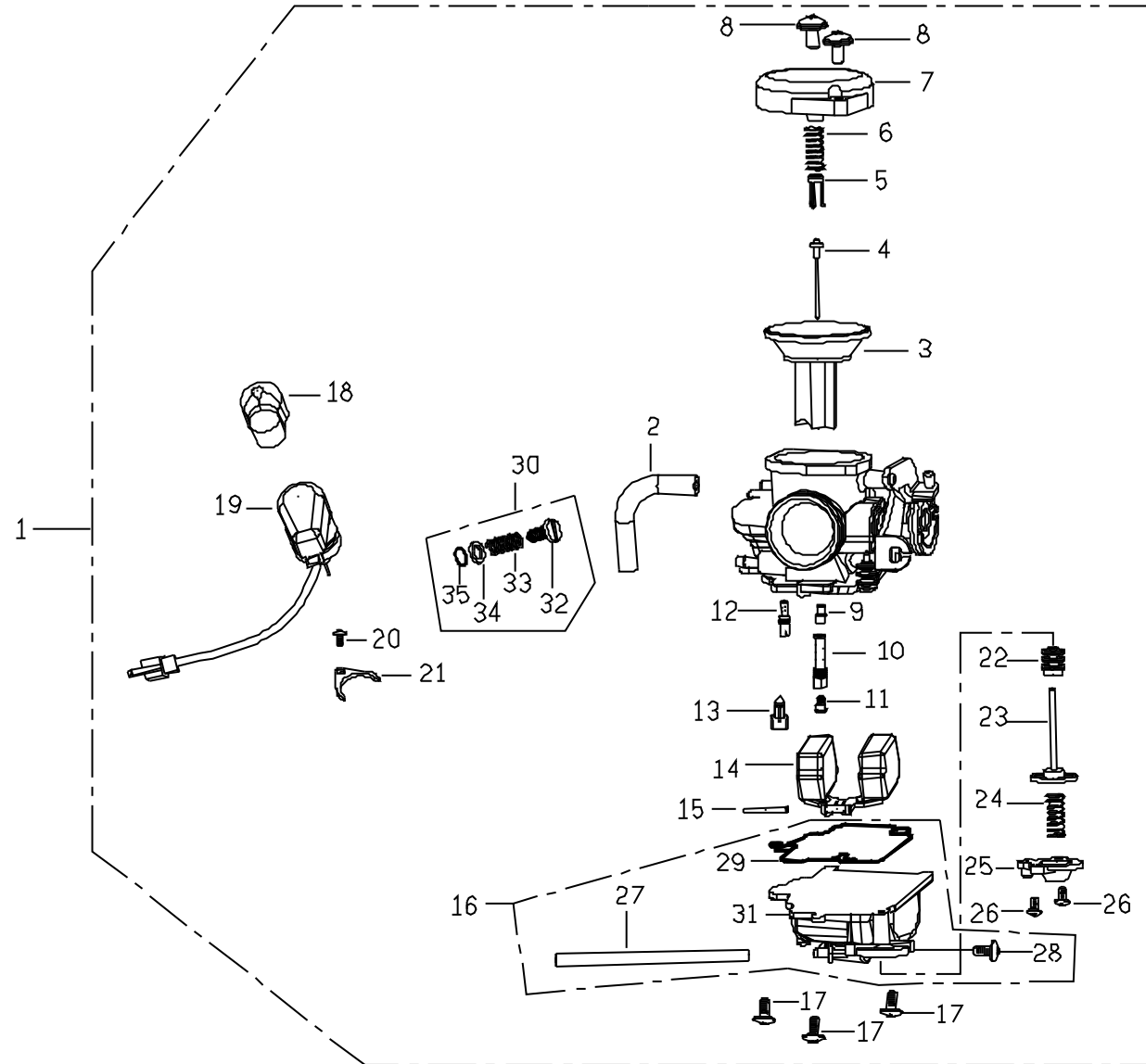

## E6 化油器(PA125/125)

No.	Part No.	Q' TY	PART NAME	PART NAME	REMARK
項目	零件號碼	數量	零件中文名稱	零件英文名稱	備註
1	C21510010004	1	化油器總成(CVK24,069型)	CARBURETOR ASSY	PA125
2	16199-GY6-9000	1	橡膠管	TUBE (AV)	
3	N446-12C00	1	螺絲組	SCREW (P.S)	
4	1402-923-2201	1	真空活塞組	VACUUM PISTON COMP	PA125
5	N425-4HJBN	1	油針	JET NEEDLE COMP	PA125
6	122--805-7000	1	閥板	SPG SEAT	
7	1290-A23-2000	1	壓縮彈簧	SPG;COMPR	
8	1030-873-7003	1	上蓋	TOP	PA125
9	0110-803-1100	2	螺絲組	SCREW,PAN	
10	N426-33C00	1	油針噴嘴	NEEDLE JET	
11	N413-18C00	1	油針噴嘴套管	NEEDLE JET HOLDER	
12	99101-116-0920	1	主噴嘴(#92)	MAIN JET	PA125
13	16155-ZG8-L100	1	浮動閥組	FLOAT VALVE COMP	
14	100A-KEB0-0381	1	低速噴嘴(#38*#38)	SLOW JET COMP	PA125
15	1052-862-2101	1	浮筒組	FLOAT COMP	
16	W9525-25250	1	浮筒銷	FLOAT ARM PIN	
17	N350-61C00	1	油室組	FLOAT CHAMBER COMP	PA125
18	93500-04012-1H	3	螺絲組	SCREW,PAN	不提供
19	1230-856-7001	1	保溫蓋	COVER	
20	4000-094-0000	1	自動旁通起動組	AUTO BYSTARTER ASSY	PA125
21	93892-04008-18	1	墊片螺絲	SCREW WASHER	
22	1090-873-2001	1	固定片	SET PLATE	
23	1028-054-7000	1	封閉蓋	RVBBER CAP	
24	1201-830-2201	1	膜片組	DIAPHRAGM COMP	PA125
25	1290-A07-2000	1	壓縮彈簧	SPG;COMPR	
26	1230-851-2001	1	蓋	COVER (ACCP)	
27	93500-04010-1H	2	螺絲組	SCREW	
28	1785-402H-0040	1	橡膠管	TUBE (OF)	

E7 DRIVEN PULLEY

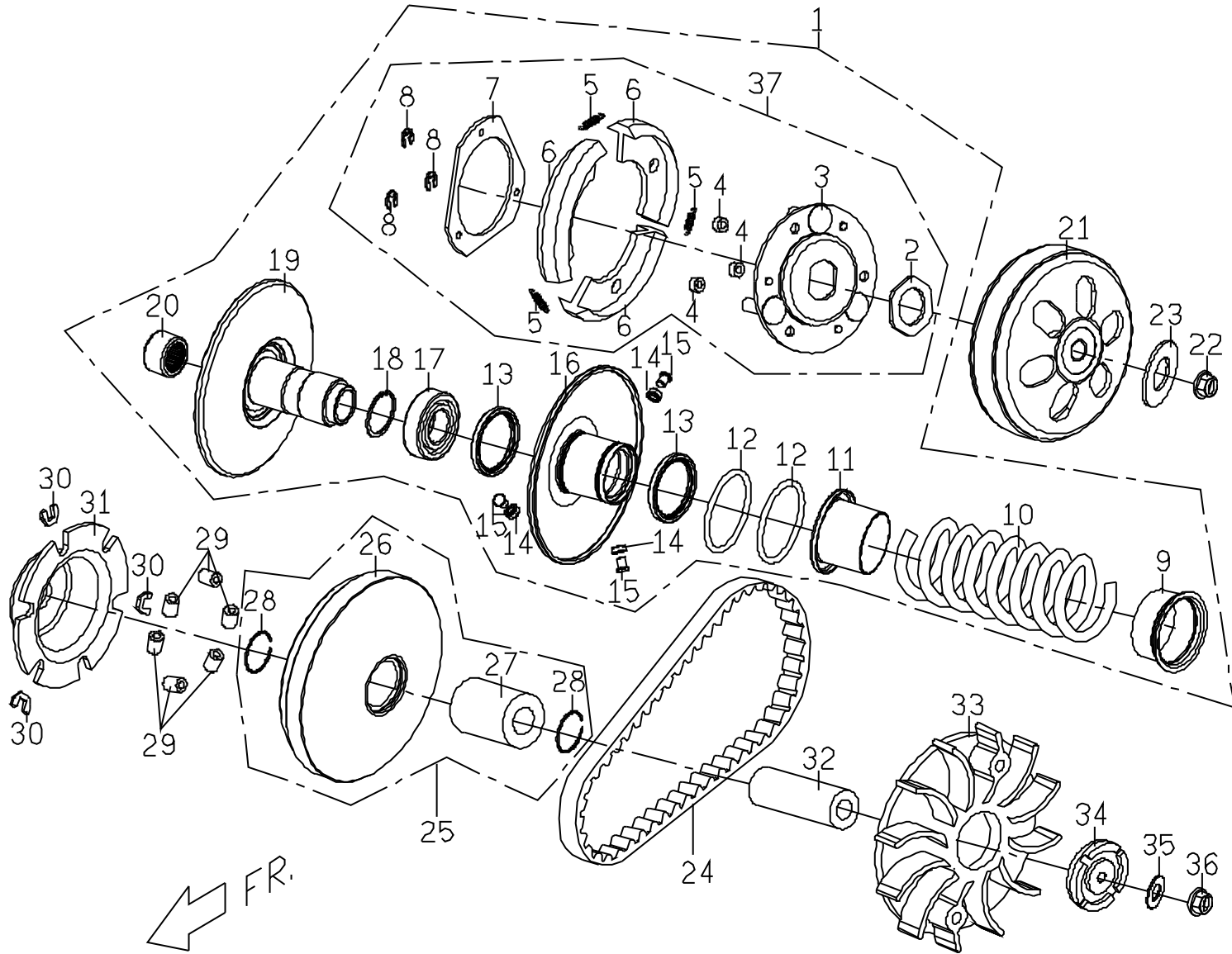

**E7.2 PA125 DRIVEN PULLEY****AVAILABLE FOR PA-125**

No.	Part No.	Q'TY	PART NAME	PART NAME	REMARK
1	C1123700000	1	被驅動面皮帶輪組合	BELT PULLEY COMP,DRIVEN FACE	
2	P1123410000	1	特殊螺帽	NUT	
3	C1123300000	1	驅動板本體組合	BODY COMP,DRIVE PLATE	
4	C1123420000	3	離合器阻尼橡膠	DAMPER RUBBER,CLUTCH	
5	C1123430000	3	離合器彈簧	SPRING,CLUTCH	
6	C1123440000	3	離合器比重組	WEIGHT SET,CLUTCH	
7	C1123450000	1	離合器壓板	PRESSURE PLATE,CLUTCH	
8	92180700000	3	E型扣環	RETAINING RING E TYPE	
9	C1123330000	1	彈簧套筒	COLLAR,SPRING	
10	C1123520000	1	被驅動面彈簧	SPG,DRIVEN FACE	
11	C1123530000	1	密封套筒	SEALED SOCKET	
12	95514000001	2	O形環	O-RING	
13	95593441400	2	G型油封	OIL SEAL G TYPE	
14	C1123250000	3	襯套	BUSH	
15	C1123240000	3	導滾銷	PIN,GRIDE	
16	C1123210000	1	活動被驅動面本體組合	BODY COMP,DRIVEN FACE	
17	96520690200	1	單封深槽滾珠軸承	DEEP GROOVE BALL BEAR ONE SEAL	
18	92162400000	1	C型扣環	RETAINING RING C TYPE	

**E7.2 PA125 DRIVEN PULLEY****AVAILABLE FOR PA-125**

No.	Part No.	Q'TY	PART NAME	PART NAME	REMARK
項目	零件號碼	數量	零件中文名稱	零件英文名稱	備註
19	C1123110000	1	被驅動面本體組合	DOBY COMP,DRIVEN FACE	
20	96550202900	1	滾針軸承	NEEDLE BEARING	
21	C1123510000	1	離合器外套本體組合	OUTER BODY COMP,CLUTCH	
22	92041200002	1	六角凸緣螺帽(M12)	HEXAGON FLANGE NUT (M12)	
23	92141200005	1	平墊圈	PLAIN WASHER	
24	C21220000001	1	皮帶	BELT	
25	C11211000001	1	活動驅動面組合	FACE MOVABLE DRIVE	
26	C1251030000	1	起動棘輪	RATCHET KICK STARTER	
27	92141200005	1	平墊圈	PLAIN WASHER	
28	92041200002	1	六角凸緣螺帽(M12)	HEXAGON FLANGE NUT (M12)	
29	C11212000001	6	配重滾子組合	WEIGHT ROLLER COMP.(BLUE)	
30	C1121321000	3	滑塊	SIDE PIECE	
28	C1121310000	1	斜坡板	RAMP PLATE	
29	C1121050000	1	活動驅動面輪殼	BOSS,MOVABLE DRIVE FACE	
33	C11210600001	1	驅動面	DRIVE FACE	
34	C1123600000	1	驅動板組合	DRIVEN PULLEY ASSY.	

E8 發電機 / 風扇罩  
 FAN COVER, GENERATOR

ENGINE OIL QUANTITY  
 PLEASE USE ASSIGNED OIL SAE 15W40  
 TOTAL QUANTITY 0.80L  
 DISPLACEMENT QUANTITY 0.80L  
 IF OIL DOWN PLEASE USE IN LEVEL GAGE  
 TO CHECK IF IT IS LOW OIL  
 CHECK OIL LEVEL IN POSITION OFF POSITION  
 EVERY 3 MINUTES OF RUNNING

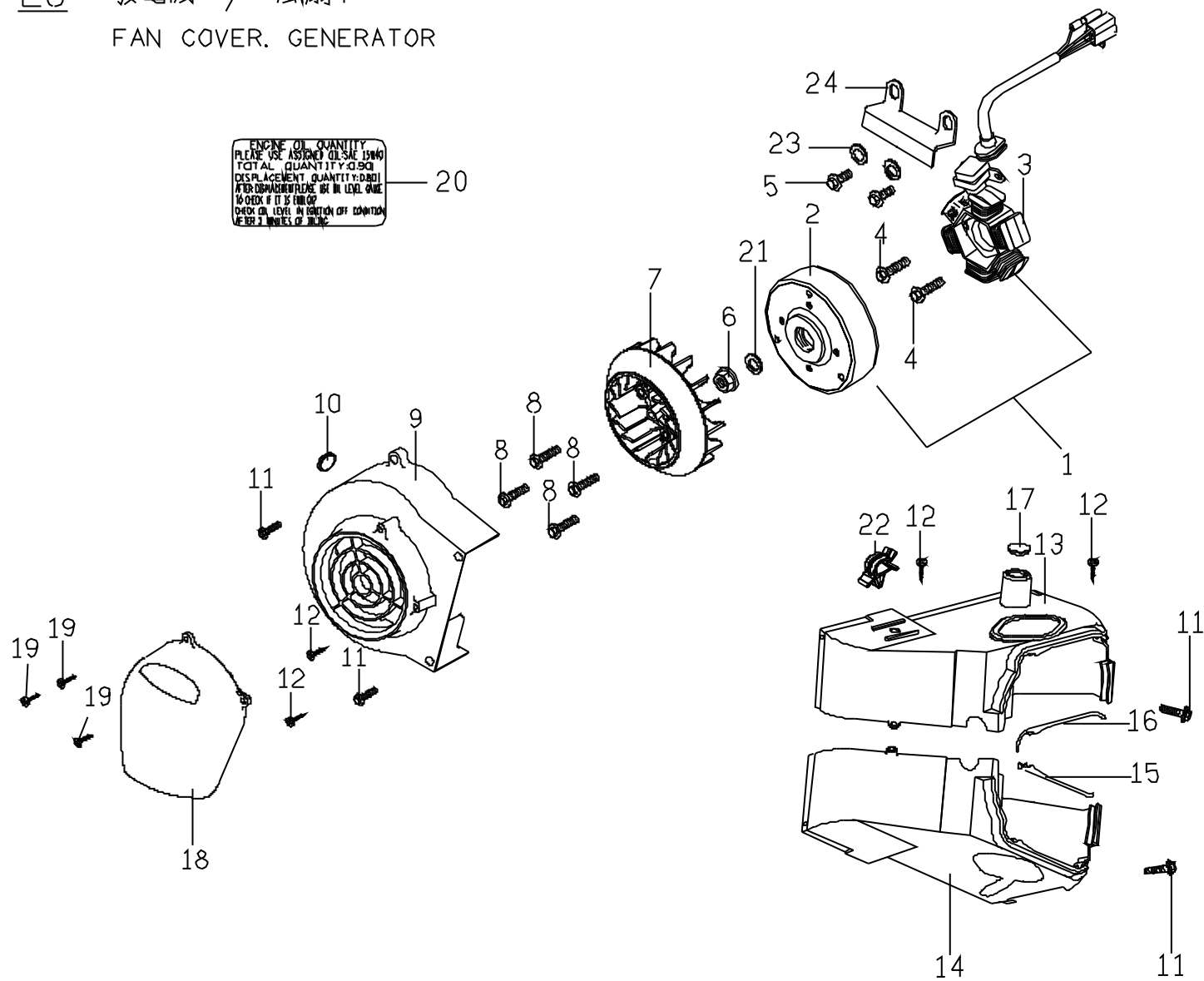

## E8. PA125\_STARTING MOTOR

No.	Part No.	Q'TY	PART NAME	PART NAME	REMARK
項目	零件號碼	數量	零件中文名稱	零件英文名稱	備註
1	C1081000000	1	機油泵總成	OIL PUMP ASSY	
2	C1243030000	3	單向離合器滾柱	ROLLER ONE WAY CLUTCH	
3	C1243020000	3	套筒	COP,ROLLER SPRING	
4	G1243010000	3	壓縮彈簧	COMPRESS SPRING	
5	C12430500001	1	起動離合器凸緣	COVER CLUTCH OUTER	
6	90210801000	3	六角承窩螺栓	INNER HEX BOLT	
7	96590283200	1	滾針軸承	NEEDLE BEARING	
8	C1081070000	1	機油泵軸	SHAFT,OIL PUMP	
9	90190602700	2	六角凸緣螺栓(M6*27L)	HEXAGON FLANGE BOLT	
10	C1081030000	1	機油泵驅動齒輪	SPRKT OIL PUMP DRIVEN	
11	92040600000	1	六角凸緣螺帽(M6*1.0P)	HEXAGON FLANGE BOLT	
12	C1081220000	1	機油泵驅動鏈條	CHAIN,OIL PUMP	
13	C1081230000	1	機油分隔板	OIL SEPARATER	
14	E1681030000	2	帶墊圈盤頭螺栓	WITH SPRING WASHER HEX BOLT	
15	C1241000000	1	起動馬達組合	STARTING MOTOR COMP.	
16	95512400002	1	O形環	O RING	
17	90190601601	2	六角凸緣螺栓	HEXAGON FLANGE BOLT	
18	C1242040000	1	起動減速齒輪軸	SHAFT,STARTET REDUCTION GEAR	
19	C1242010000	1	起動減速齒輪	GEAR,STARTER REDUCTION	
20	C12430000001	1	單向離合器總成	ONE WAY CLUTCH ASSY.	
21	NA	1	單向離合器組合	ONE WAY CLUTCH COMP.	
22	C1244000000	1	起動離合器齒輪組合	GEAR COMP.STARTING CLUTCH	
23	92142200000	1	平墊圈	PLAIN WASHER	
24	C1243060000	1	鎖定螺帽(左牙)	NUT LOCK(L THREAD)	

E9

起動馬達

STARTING MOTOR, OIL PUMP

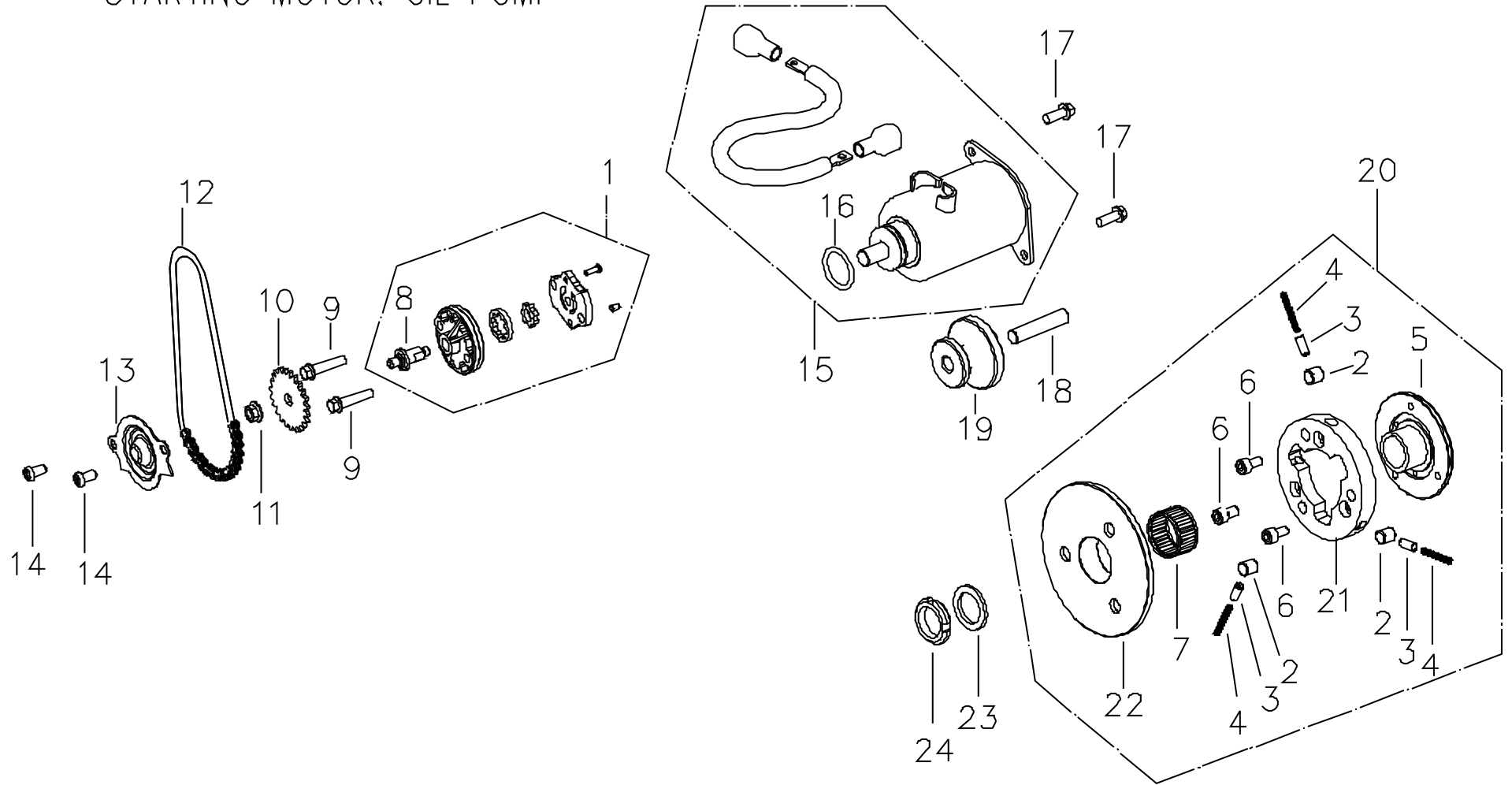

## E9 . PA125\_GENERATOR

No.	Part No.	Q'TY	PART NAME	PART NAME	REMARK
項目	零件號碼	數量	零件中文名稱	零件英文名稱	備註
1	C12210000001	1	飛輪磁電機總成(交流點燈)	AC GENERATOR ASSY(AC LIGHT)	
2	C12210100001	1	飛輪(交流點燈)	FLYWHEEL COMP(AC LIGHT)	
3	C12210200001	1	固定轉子(交流點燈)	STATOR COMP(AC LIGHT)	
4	90180602000	2	六角凸緣螺栓(M6*20L)	HEXAGON FLANGE BOLT	
5	90190501201	2	六角凸緣螺栓(M5*12L)	HEXAGON FLANGE BOLT	
6	92041200000	1	六角凸緣螺帽	HEXAGON FLANGE NUT	
7	C1043001000	1	風扇	FAN	
8	90190601204	4	六角凸緣螺栓	HEXAGON FLANGE BOLT	
9	C1042001000	1	風扇罩	FAN COVER	
10	C1042030000	1	橡膠塞	RUBBER PLUG	
11	90180602000	4	六角凸緣螺栓(M6*20L)	HEXAGON FLANGE BOLT	
12	90150501600	4	十字槽盤頭自攻螺釘(M5*16)	CR PAN HD.TAPPING SCREW	
13	C10422100001	1	冷卻罩(2)	COOLING COWL(2)	
14	C1042102000	1	冷卻罩(1)	COOLING COWL(1)	
15	C1042120000	1	冷卻罩油封(1)	SEAL,COOLING HOOD(1)	
16	C1042220000	1	冷卻罩油封(2)	SEAL,COOLING HOOD(2)	
17	C1701260000	1	橡膠塞	RUBBER PLUG	
18	C1042242000	1	風扇罩蓋	FAN COVER'S COVER	
19	90110401600	3	十字槽盤頭自攻螺釘(M5*16)	CR PAN HD.TAPPING SCREW	
20	C1603130001	1	引擎機油注意貼紙(英文)	ENG., OIL NOTICE LABEL	
21	92141200005	1	平墊圈	PLAIN WASHER	
22	C1701290000	1	塑膠鎖扣	PLASTIC LOCKER	
23	92140500014	2	平墊圈	PLAIN WASHER	
24	C1706640000	1	ACG壓板	ACG PLATE	
25	C1042270000	1	熱導風管	HEAT PIPE	

# E10 傳動齒輪箱

GEAR TRANSMISSION

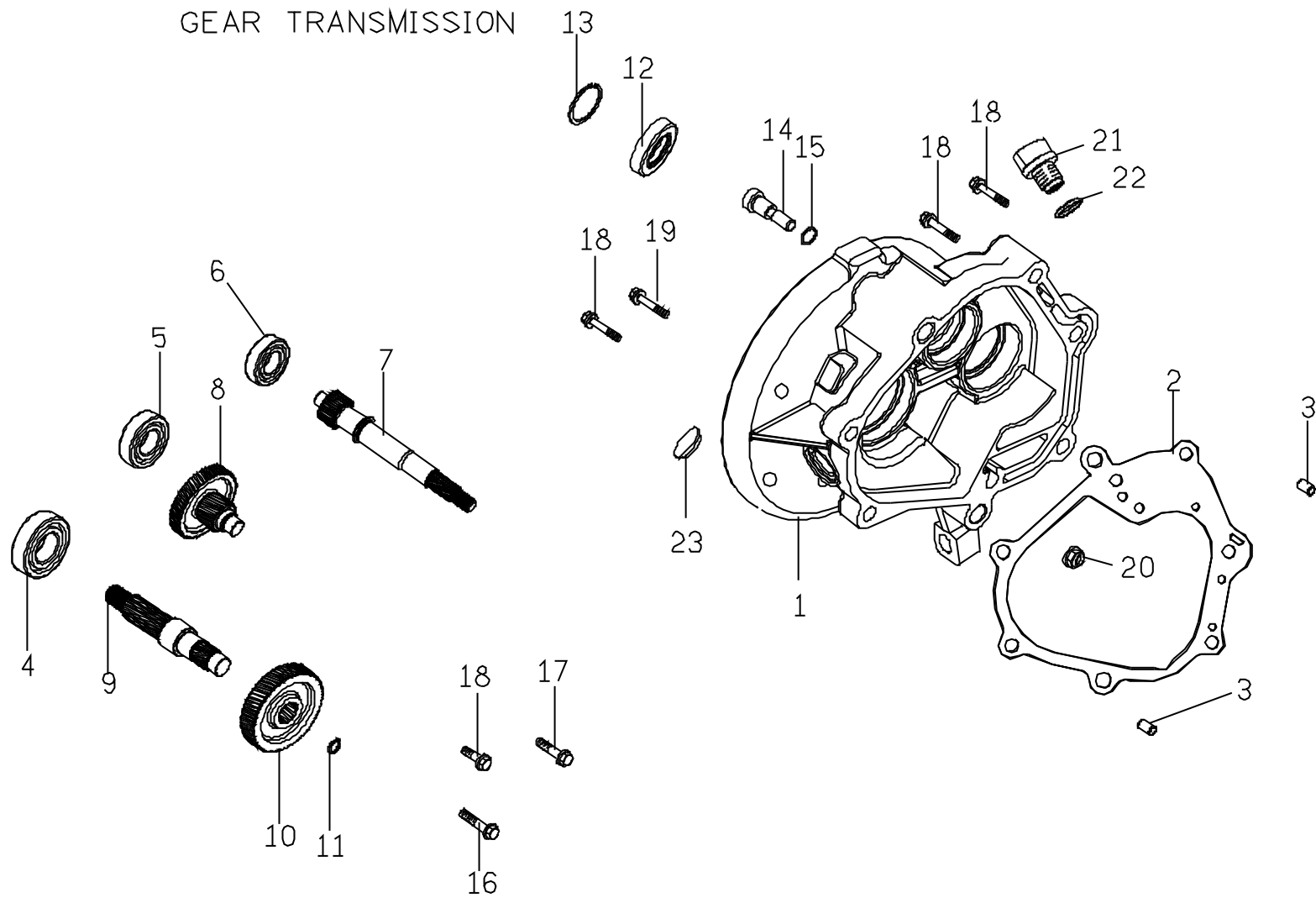
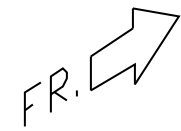

## E10. PA125\_GEARBOX

No.	Part No.	Q'TY	PART NAME	PART NAME	REMARK
項目	零件號碼	數量	零件中文名稱	零件英文名稱	備註
1	C2141011000	1	傳動箱蓋	TRANSMISSION COVER	
2	C2141020000	1	傳動箱蓋襯墊	TRANSMISSION COVER GASKET	
3	93541001401	2	定位銷(10*14)	LOCK PIN	
4	96510630100	1	深槽滾珠軸承(6301)	BALL BEARING	
5	96510600200	1	深槽滾珠軸承(6002)	BALL BEARING	
6	96530622200	1	雙封滾珠軸承(6222)	BALL BEARING.DOUBLE SEALED	
7	C11411000001	1	驅動軸(15T)	DRIVE SHAFT (15T)	
8	C11412000001	1	惰齒輪組合(42T)	IDLE GEAR COMP. (42T)	
9	C1141411000	1	後軸	AXLE DRIVE	
10	C1141310000	1	最終齒輪	FINAL GEAR	
11	92172000000	1	C型扣環	RETAINING RING C TYPE	
12	95572742700	1	TC形油封(φ 42*φ 25.8*7t)	OIL SEAL TC TYPE	
13	92165000000	1	C型扣環(孔用)	RETAINING RING C TYPE	
14	C2407431000	1	煞車軸蹄樞軸	PIVOT REAR BK.SHDE	
15	95510800000	1	O形環(7.5*1.5)	O RING	
16	90190805001	1	六角凸緣螺栓(M8*50L)	HEXAGON FLANGE BOLT	
17	90190804501	1	六角凸緣螺栓(M8*45L)	HEXAGON FLANGE BOLT	
18	90190804003	4	六角凸緣螺栓(M8*40L)	HEXAGON FLANGE BOLT	
19	90190802600	1	六角凸緣螺栓(M8*26L)	HEXAGON FLANGE BOLT	
20	92060800000	1	六角凸緣螺帽(M8*1.25P)	HEXAGON FLANGE NUT	
21	P1062150000	1	機油螺栓	OIL BOLT	
22	95511300001	1	O形環	O-RING	

E11 空氣濾清器組合  
AIR CLEANER COMP.

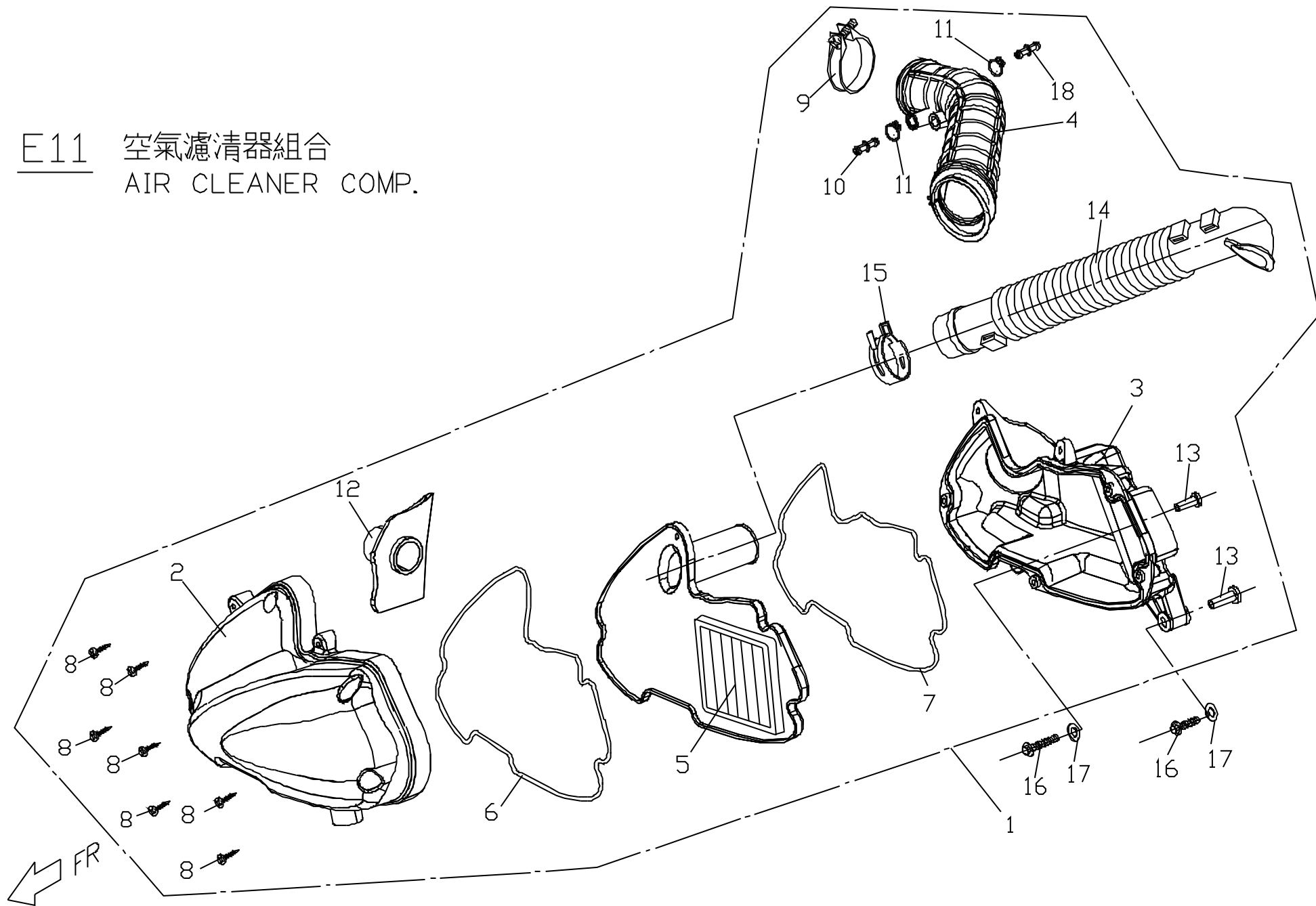

## E11 空氣濾清器組合 (PA125/125)

No.	Part No.	Q' TY	PART NAME	PART NAME	REMARK
項目	零件號碼	數量	零件中文名稱	零件英文名稱	備註
1	P62620000003	1	空氣濾清器組合	AIR CLEANER COMP	PA125
2	P6262020000	1	空氣濾清器蓋	COVER,AIR CLEANER	
3	NA	1	空氣濾清器本體	BODY,AIR CLEANER	不提供
4	P62620800002	1	空氣濾清器連接管	CONNECTION DIPE	
5	P6262030000	1	空氣濾清器紙蕊	AIR FILTER	
6	P6262040000	1	空氣濾清器紙蕊襯墊(1)	PACKING,AIR FILTER	
7	P6262230000	1	空氣濾清器紙蕊襯墊(2)	PACKING,AIR FILTER	
8	90150502000	7	十字槽圓頭自攻螺釘	C-R ROUND HD.TAPPING SCREW	
9	P62621100001	1	管束(鍍黑)	CLIP(BLACK)	PA125
10	P6262360000	2	二通接管	PIPE, TWO WAY	
11	92201200000	2	軟管夾	CLIP	PA125
12	P6262050000	1	進氣管(IN)	INLET PIPE	
13	P6262060000	2	襯套	BUSH	
14	P6262270000	1	進氣管	INLET CONNECTING PIPE	
15	92214000000	1	軟管夾	CLIP	
16	90190604500	1	六角凸緣螺栓(M6*45L)	HEXAGON FLANGE BOLT	
17	90190603500	1	六角凸緣螺栓(M6*35L)	HEXAGON FLANGE BOLT	
18	P6262370000	1	管塞	TUBE PLUG	

E12 BUBU  
MUFFLER

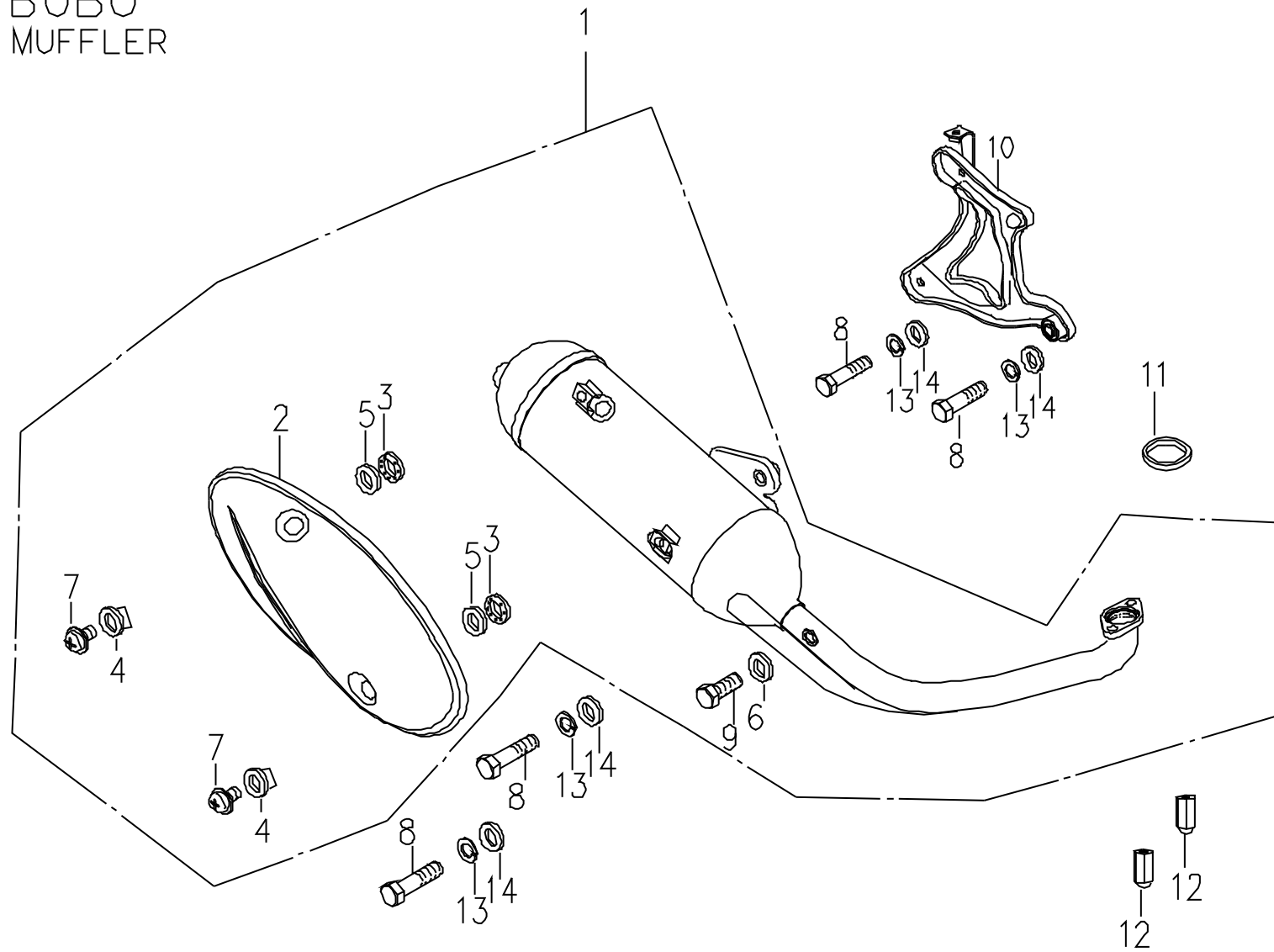



E13 REAR WHEEL

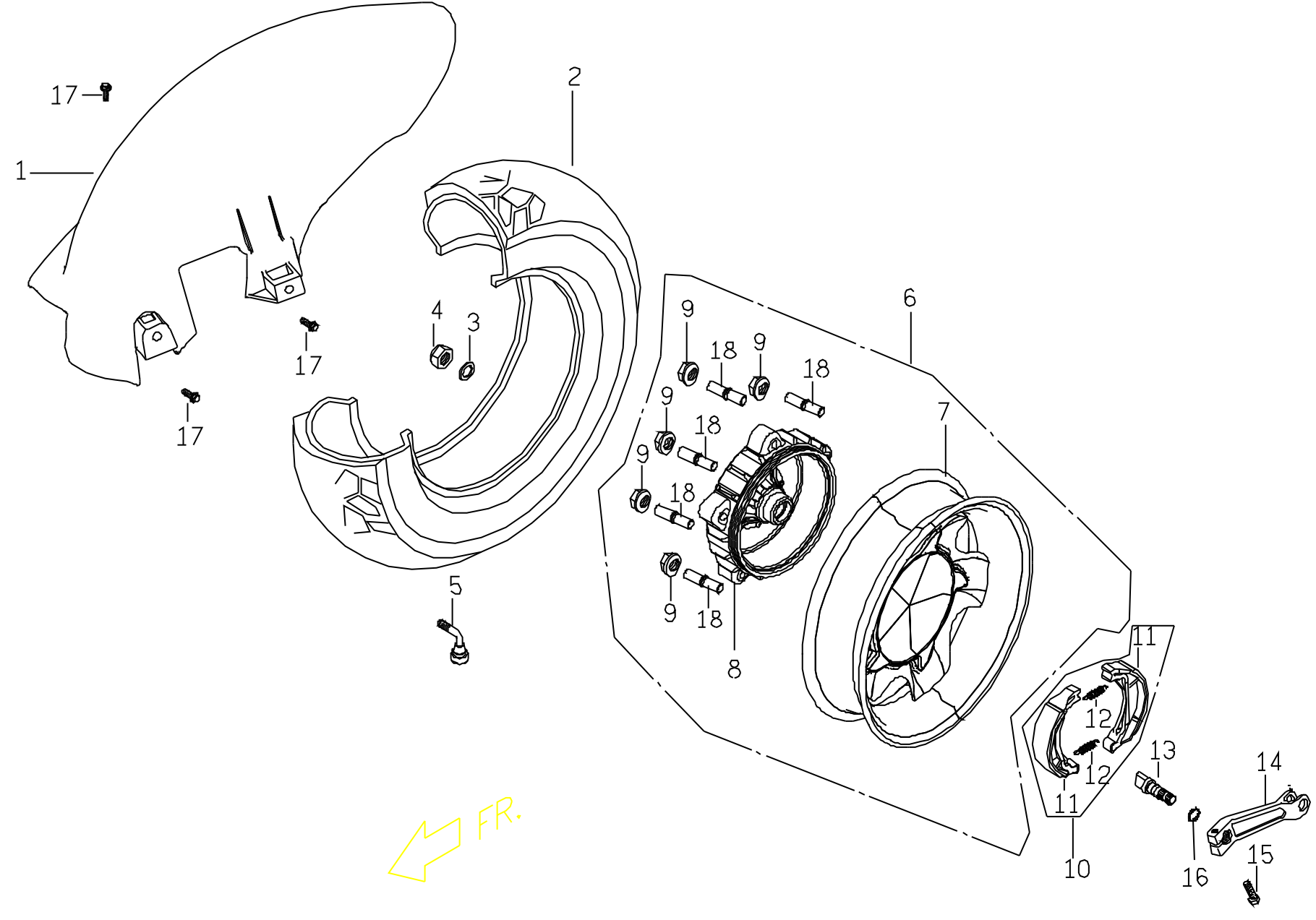



F1.2 BUBU (MOVABLE MODEL)  
COVER UPPER & LOWER, HANDLE BAR,  
HEAD LIGHT

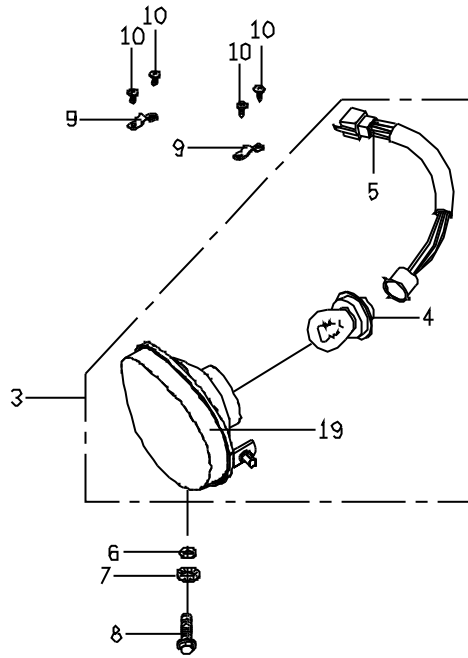

FR.

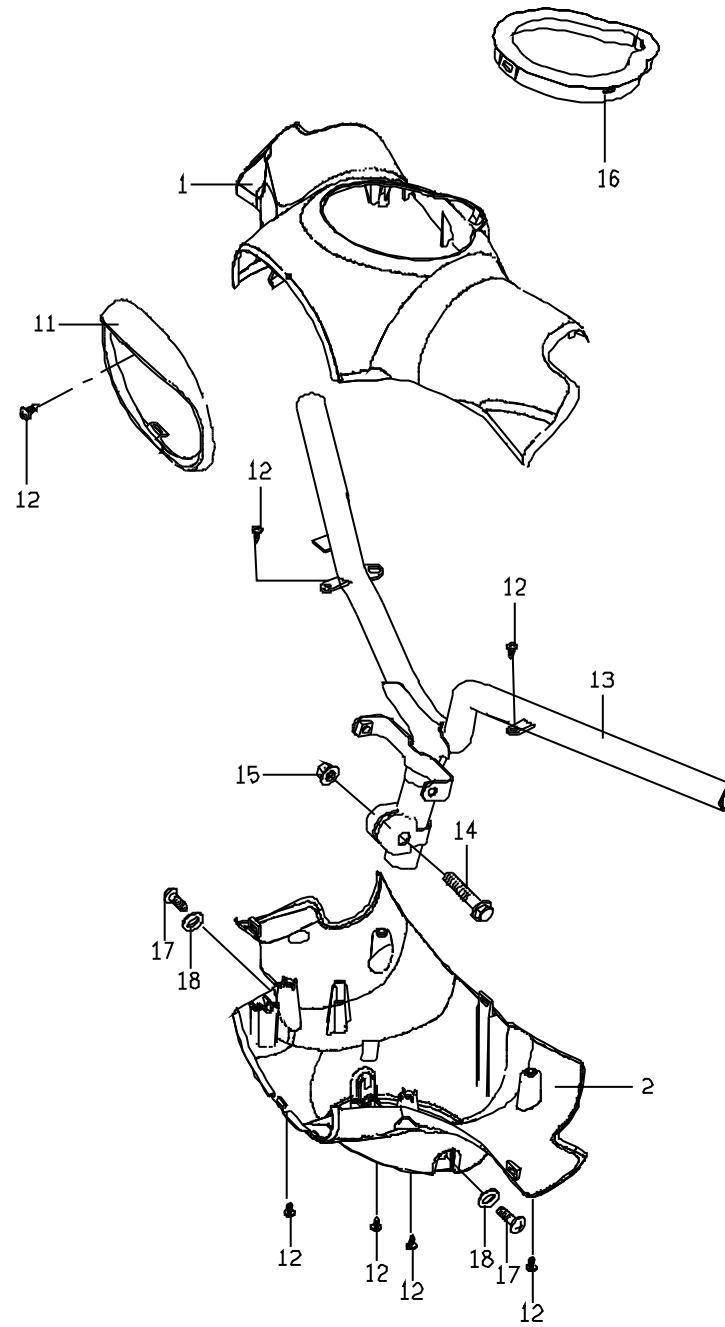



F2 BUBU100  
SPEEDOMETER

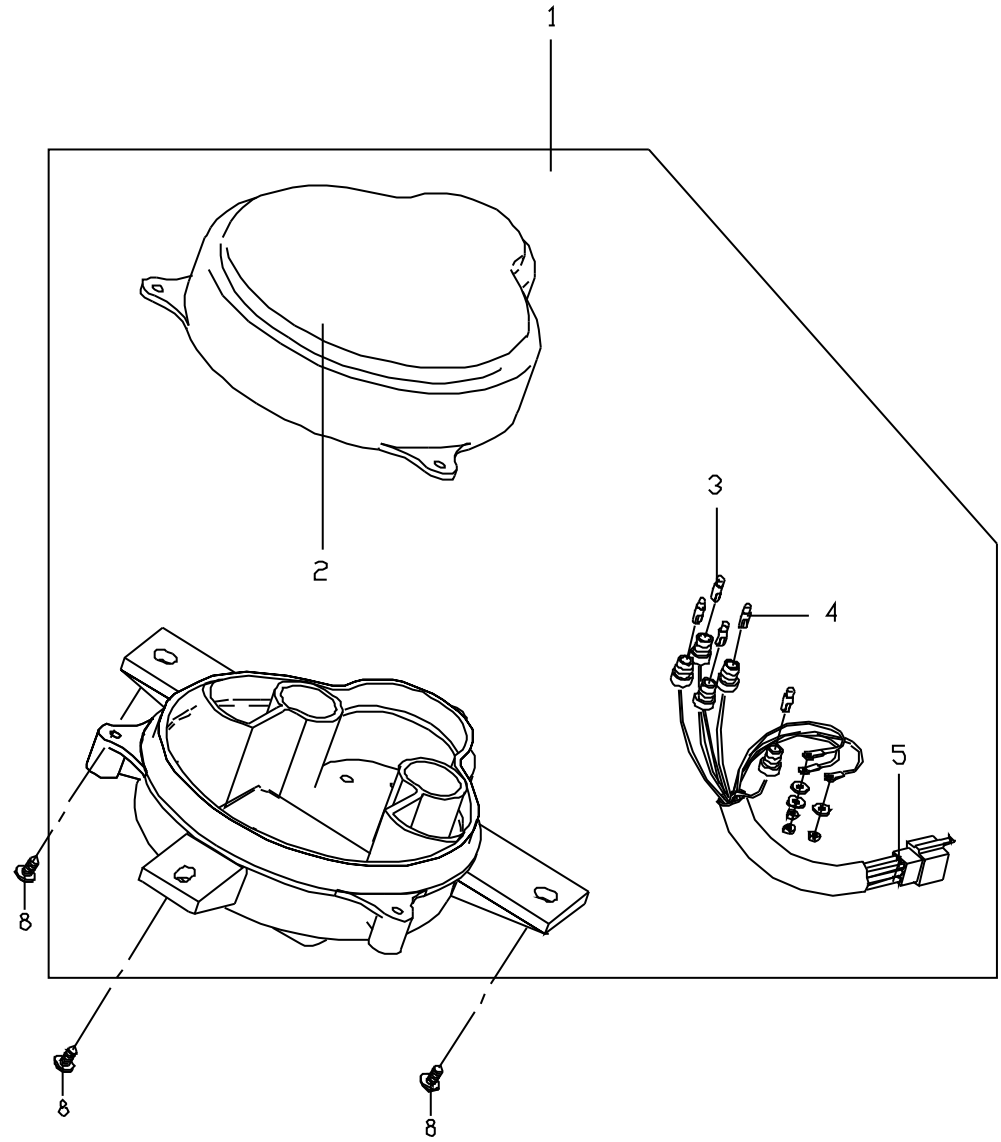
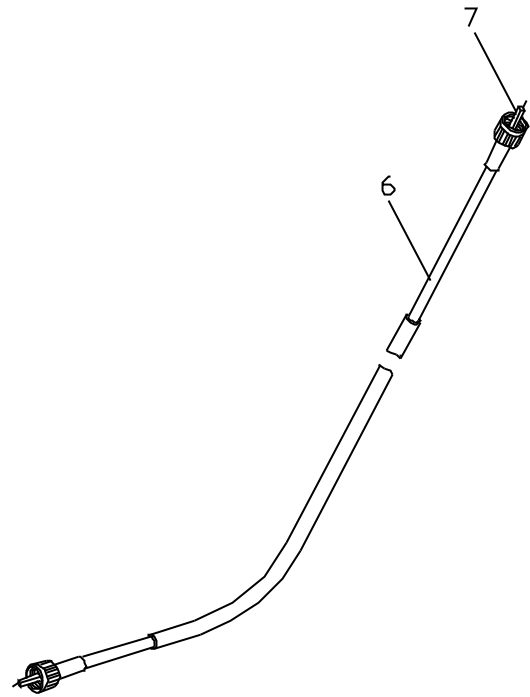



**BUBU100**  
F3 CABLE.SWITCH.BACK MIRROR(Disk)

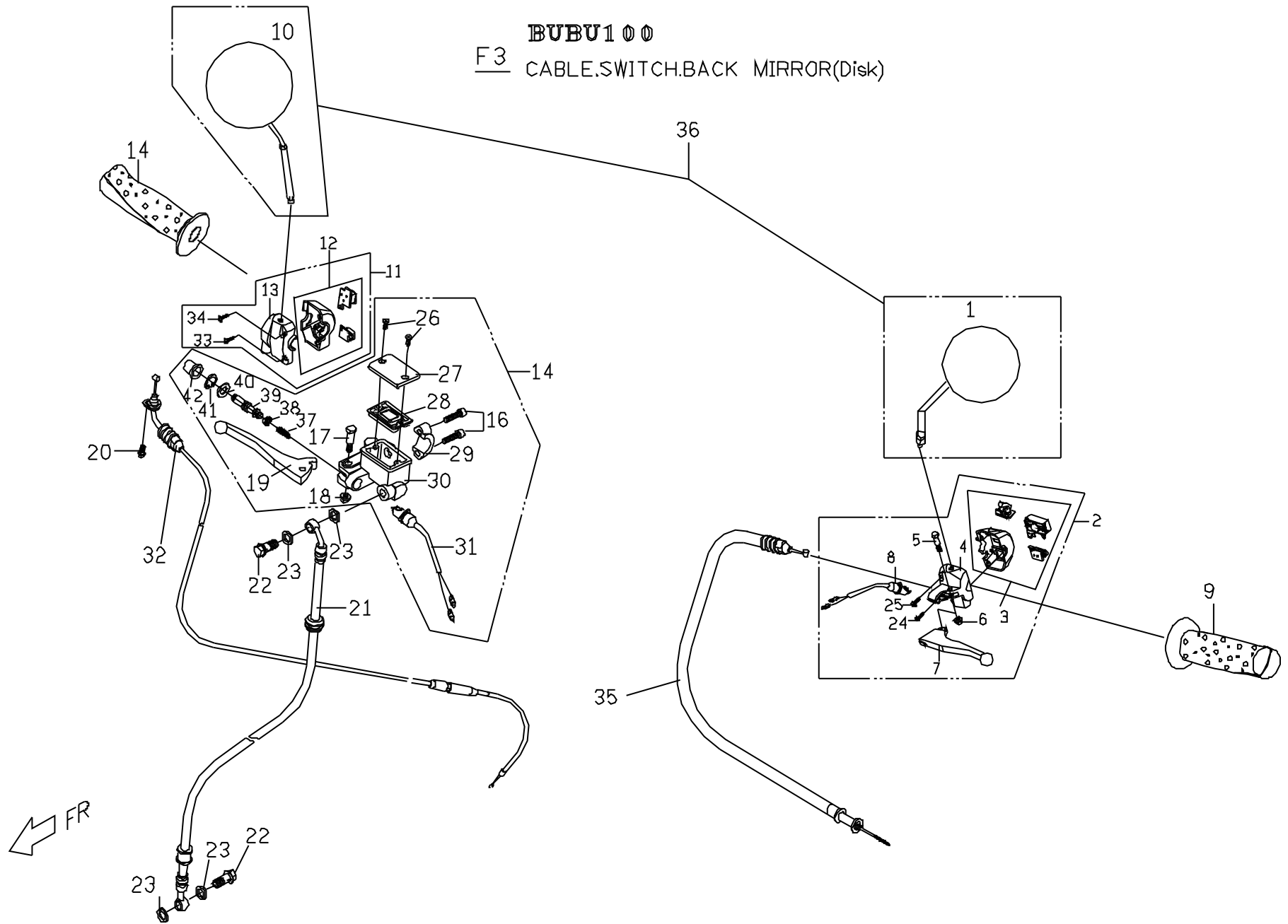

## F3. PA125\_CABLE / SWITCH

No.	Part No.	Q'TY	PART NAME	PART NAME	REMARK
項目	零件號碼	數量	零件中文名稱	零件英文名稱	備註
1	P561F0100001	1	左後視鏡（電鍍件）	LH BACK MIRROR(STAINLESS)	
2	P1546003000	1	左把手開關總成	LEVER HOLDER ASSY(LEFT)	
3	P154F410000	1	內夾持板2組合	CASE,SWITCH UNDER 2 COMP	
4	P154F020000	1	內夾持板1	CASE,SWITCH UNDER 1	
5	P154F030000	1	螺栓	BOLT	
6	P154F040000	1	防鬆螺帽	LOCK NUT	
7	P1543302000	1	左煞車拉桿	LEVER,LH BRAKE	
8	C2548220000	1	左安全開關	LH BRK SWITCH COMP	
9	P0541000000	1	左握把總成	LH GRIP ASSY	
10	P561F0200001	1	右後視鏡（電鍍件,左牙）	RH BACK MIRROR(STAINLESS)	
11	P1548003000	1	右把手開關總成	LEVER HOLDER ASSY,RH	
12	P154H190000	1	內夾持板2組合	CASE,SWITCH UNDER 2 COMP	
13	P154H020000	1	內夾持板1	CASE,SWITCH UNDER 1	
14	P0542000000	1	右握把總成	RH GRIP ASSY	
15	P5403000000	1	前煞車總泵	FRT BRAKE MASTER CYLINDER	
16	P140C250000	2	內六角螺栓	HEX SOCKET HEAD BOLT	
17	P140C220000	1	螺栓	BOLT	
18	P140C230000	1	凸緣螺帽	FLANGE NUT	
19	P140C191000	1	右煞車拉桿	LEVER,RH BRAKE	
20	90050501200	1	十字槽圓頭自攻螺釘	C-R RECESS PAN HD TAPPING SCREW	
21	P6403600000	1	煞車油管總成	FRT BRAKE FLUID HOSE COMP	
22	P1403810000	2	煞車油管通油螺栓	JOINT BOLT,BRAKE HOSE	
23	92141000002	4	平墊圈	PLAIN WASHER	
24	P154F390000	1	埋頭螺釘	SCREW,PAN HEAD	
25	P154F400000	1	埋頭螺釘	SCREW,PAN HEAD	
26	P140C130000	2	螺絲	SCREW	
27	P140C120000	1	油杯蓋	CAP,RESERVOIR	
28	P140C110000	1	皮膜	DIAPHRAGM,RESERVOIR	
29	P140C240000	1	夾持具	BRACKET,MASTER CYLINDER	



F4 BUBU100  
FRONT FORK

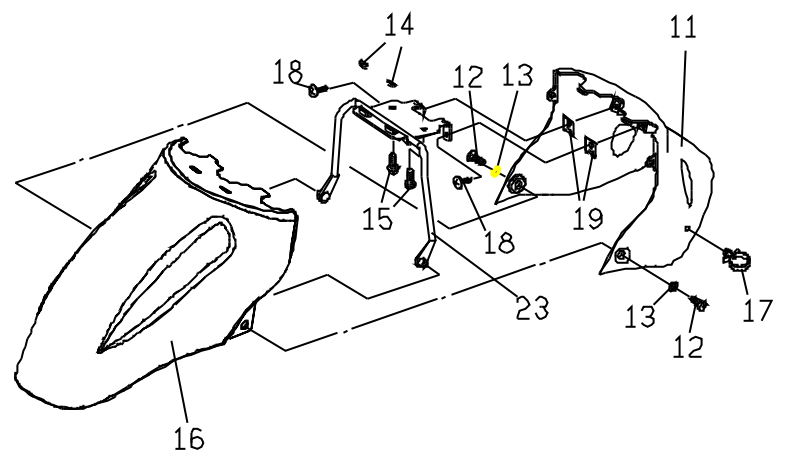

FR.

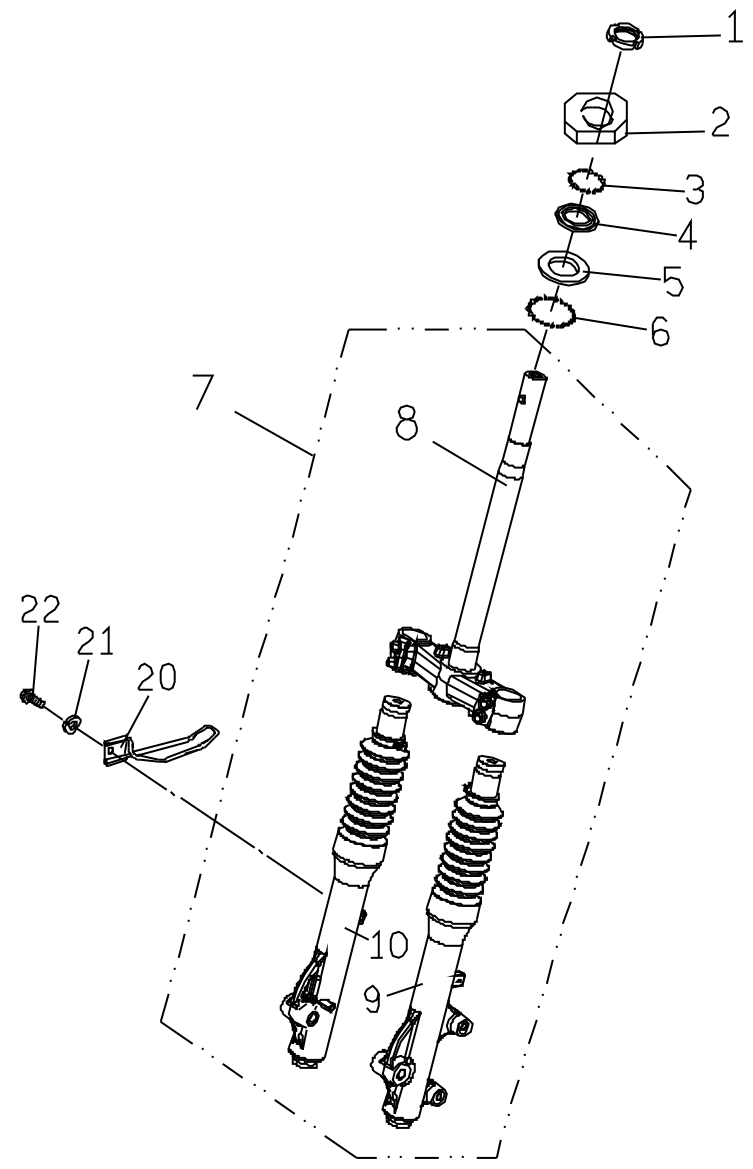

## F4. PA125\_FRONT FORK

No.	Part No.	Q'TY	PART NAME	PART NAME	REMARK
項目	零件號碼	數量	零件中文名稱	零件英文名稱	備註
1	P1443040000	1	轉向軸防鬆螺帽	STEERING SHAFT LOCK NUT	
2	P6444051000	1	上座環型螺帽	OUTER BEARING CAGE	
3	99010500000	22	鋼珠(3/16")	BEARING BALL(3/16")	
4	P1443020000	1	軸承外座	UPPER BEARING CAGE	
5	C1443011000	1	軸承底座	LOWER BEARING CAGE	
6	99010600000	19	鋼珠(1/4")	BEARING BALL(1/4")	
7	P6443000000	1	前叉總成(碟式)	FRONT FORK ASSY(DISK)	
8	P644C200000	1	下三角架組總成	UNDER BRACKET,COMP	
9	P644C210000	1	左外筒總成	LH OUTER TUBE ASSY	
10	P644C220000	1	右外筒總成	RH OUTER TUBE ASSY	
11	C2632601000	1	前土除,後段	FRONT FENDER,RR SECTION	
12	90150501601	2	十字槽扁圓頭自攻螺釘	C-R RECESS HD.TAPPING SCREW	
13	90040601400	2	十字槽盤頭機器螺釘	C-R MACHINE HD.TAPPING SCREW	
14	C2632020000	2	橡膠環	RUBBER BRACKET	
15	90190601200	2	六角凸緣螺栓	HEXAGON FLANGE BOLT	
16	P6632000000	1	前土除,前段	FRONT FENDER,FR SECTION	ADD COLOR CODE
17	92362328000	1	扣具	CABLE CLIP	
18	92140600017	2	平墊圈	PLAIN WASHER	
19	92370500003	2	U型彈簧螺帽	SPRINT NUT U-TYPE	
20	C2544020000	1	碼錶導線束圈(右)	CABLE CLIP COMP,RIGHT	
21	90190601200	1	六角凸緣螺栓	HEXAGON FLANGE BOLT	
22	92110600000	1	彈簧墊圈	SPRING WASHER	
23	C2632010000	1	前土除固定架(E.D)	FRT.FENDER FIXING FRAME	

F5.2 TIRE.FRT WHEEL.FRT CALIPER.(DISK)

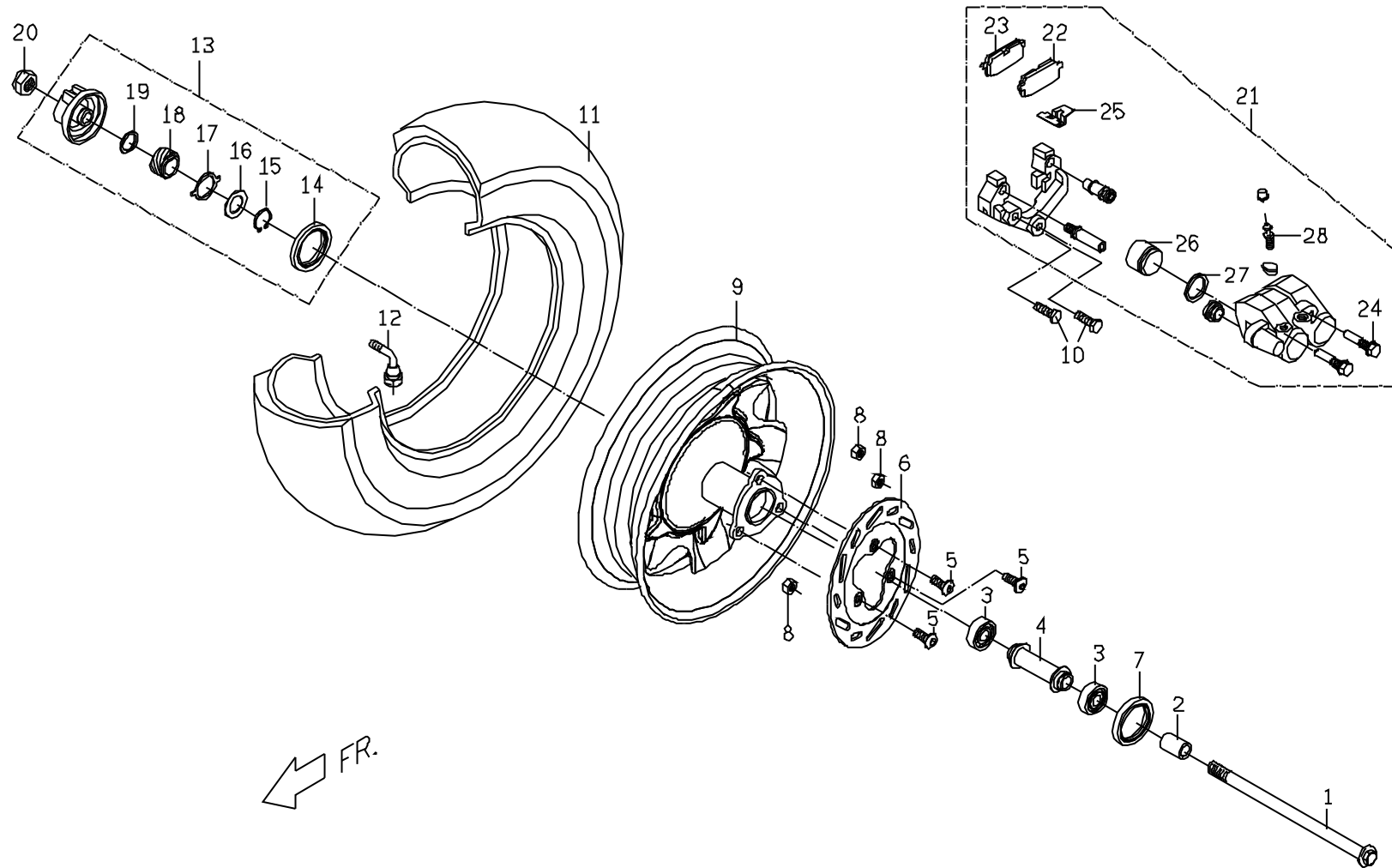

## F5. PA125\_FRT WHEEL ASSEMBLY

No.	Part No.	Q'TY	PART NAME	PART NAME	REMARK
項目	零件號碼	數量	零件中文名稱	零件英文名稱	備註
1	C2402500000	1	前輪軸	AIX,FR WHEEL	
2	P14010100001	1	間隔環	SPACER	
3	96520620100	2	單封深槽滾珠軸承(6201U)	ONE SHLIED BALL BEARING(6201U)	
4	P5402400000	1	間隔環組合(碟式)	SPACER COMP	
5	C1403510000	3	前煞車盤螺絲	SCREW,FRT BRK DISK	
6	C240C5020002	1	前煞車圓盤( 190mm)	DISC FRONT BRAKE ( 190mm)	
7	95572235700	1	TC型油封	OIL SEAL	
8	C140C160000	1	放氣帽	CAP	
9	C2401104770	1	前輪圈組合(碟式) 銀灰色	FRT WHEEL RIM COMP	
10	90190804002	2	六角凸緣螺栓	HEXAGON FLANGE BOLT	
11	C240B320000	1	輪胎(3.5-10")	TIRE ASSY(3.5-10")	
12	P140B330000	1	氣門嘴	VALVE	
13	C2566002000	1	碼錶齒輪總成	METER GEAR ASSY	
14	95574052600	1	油封	OIL SEAL	
15	92171800000	1	C型扣環	" C "CLIP	
16	92141900001	1	平墊圈	PLAIN WASHER	
17	P1566050000	1	傳動片	PAD	
18	P0566040000	1	速度錶齒輪	SPEEDOMETER GEAR	
19	92141900002	1	平墊圈	PLAIN WASHER	
20	92061200001	1	防鬆螺帽	LOCK NUT	
21	C2403303000	1	前煞車夾總成	FRT BRAKE CALLIPER	
22	C240C311000	1	內剎車片組成	INSIDE PAD	
23	C240C321000	1	外煞車片組成	OUTSIDE PAD	
24	C140C141000	2	煞車片銷	SCREW	
25	C140C330000	1	軛簧	YOKE SPRING	
26	C140C040000	1	防塵圈	DUST PROOF	
27	C140C030000	1	油封圈	OIL SEAL	
28	C140C060000	1	放氣螺絲	BREED SCREW	

F6.2

BUBU (FOR MOVABLE MODEL)  
WINDSHIELD.FRT INNER COVER.

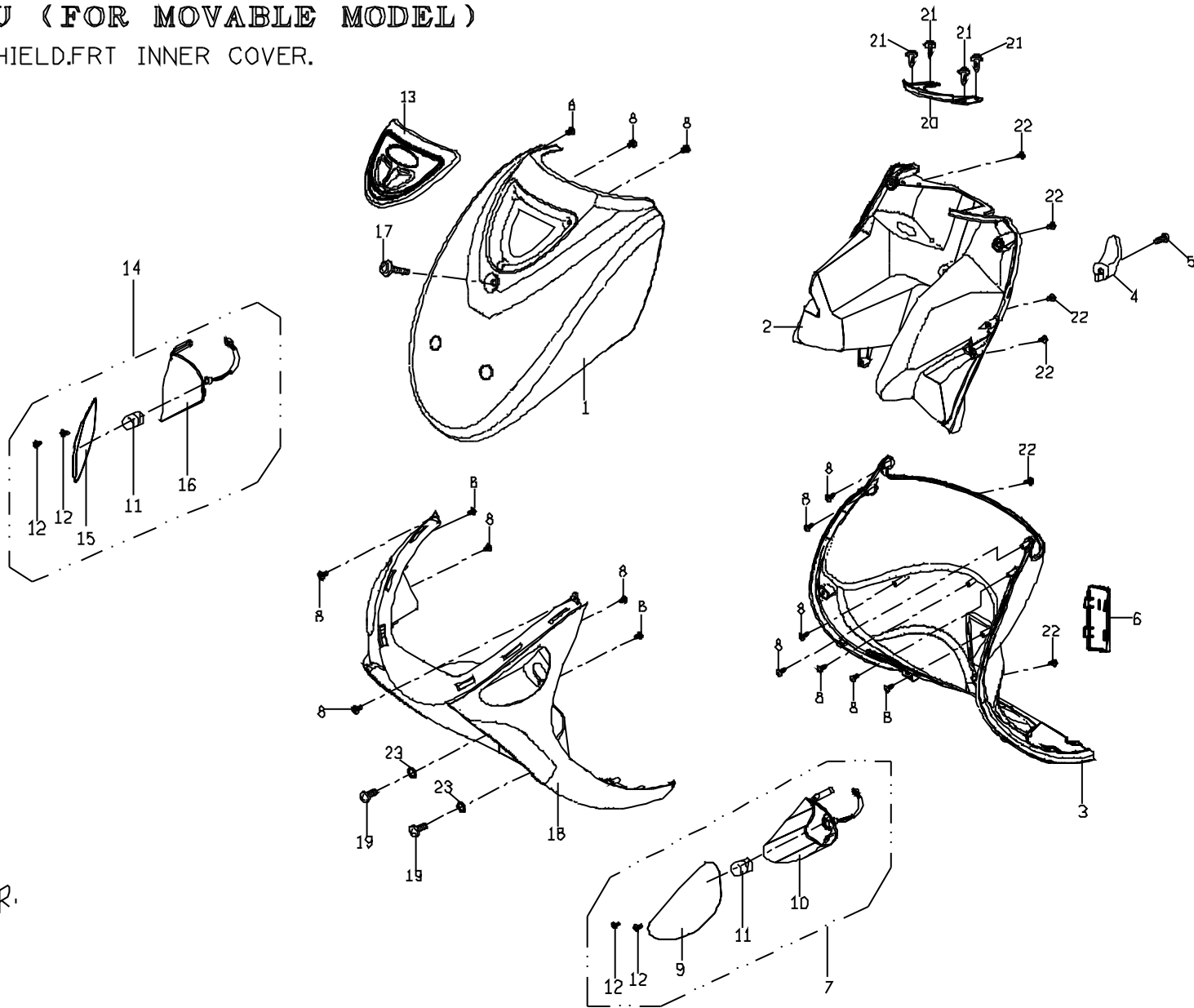



F7 **BUBU**  
STEP FLOOR.BATTERY.  
LH,RH SIDE COVER.

FR. 

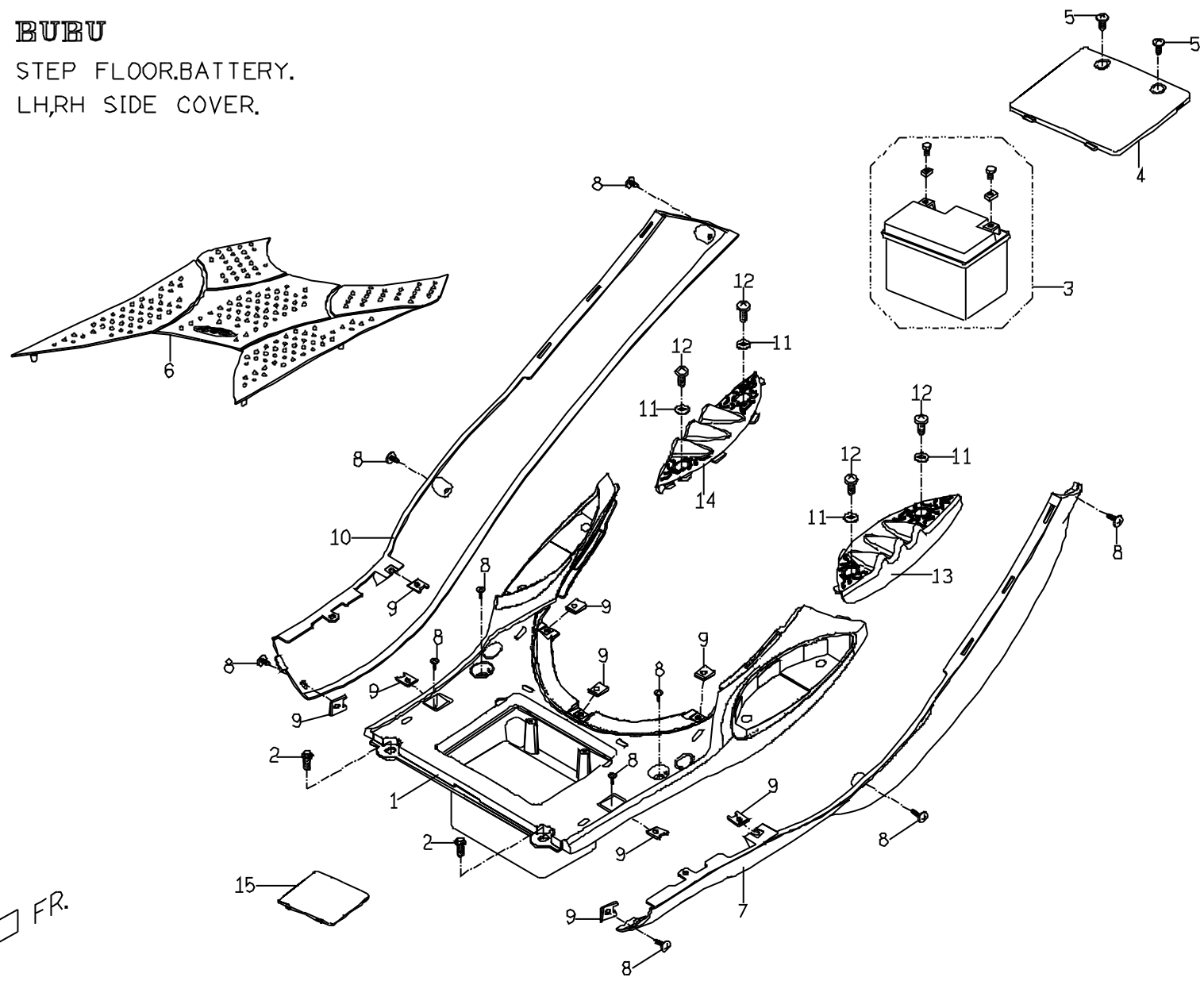



F8 BUBU

BODY COVER, BODY COVER, FRONT  
RR LUGGAGE

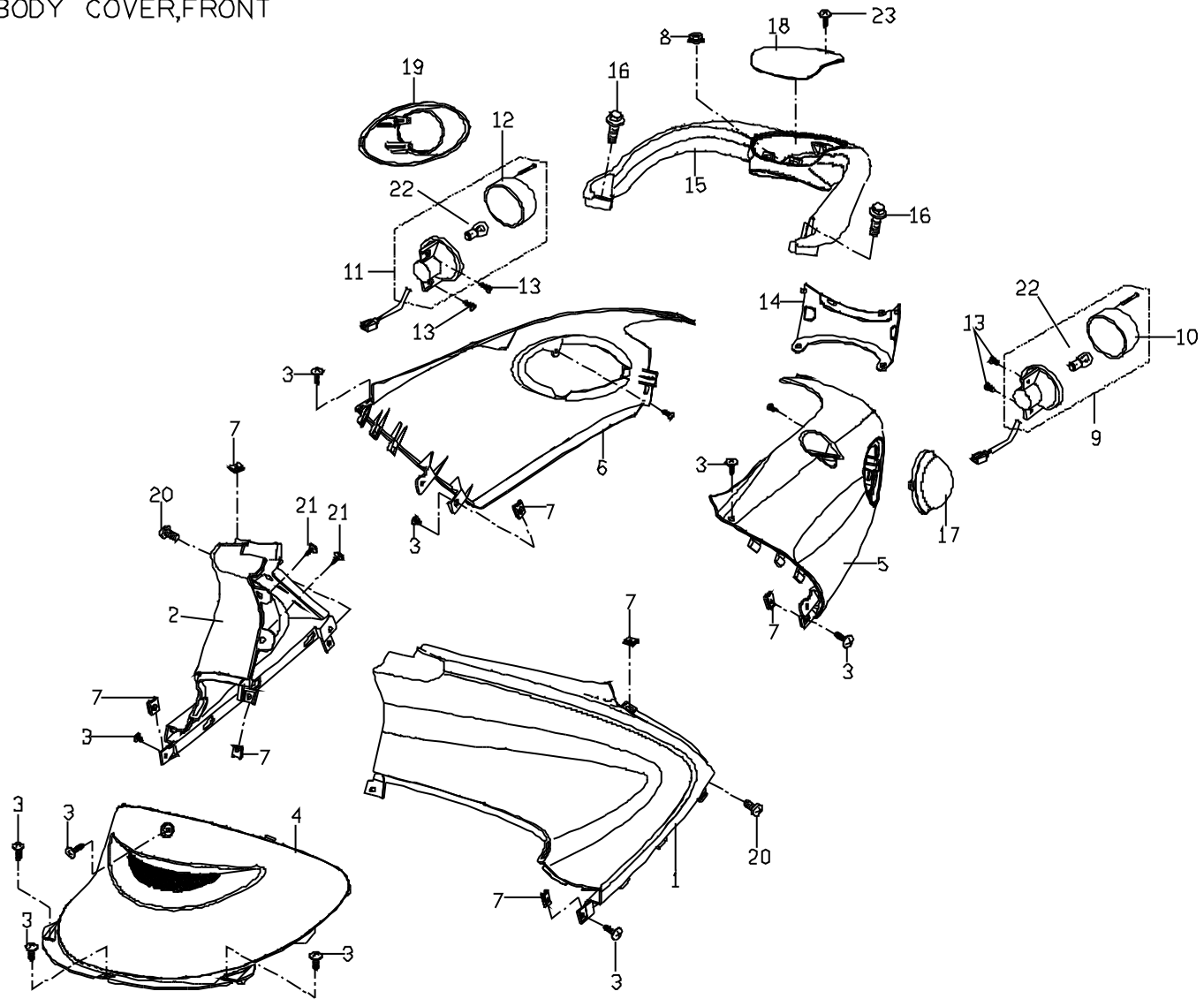

## F8. PA125\_BODY COVER / REAR LUGGAGE BRACKET

No.	Part No.	Q'TY	PART NAME	PART NAME	REMARK
項目	零件號碼	數量	零件中文名稱	零件英文名稱	備註
1	P662E010650	1	左前胸蓋(超黑)	BODY COVER,LH FRONT	
2	P662E020650	1	右前胸蓋(超黑)	BODY COVER,RH FRONT	
3	90150501600	11	自攻螺絲	C-R RECESS PAN HD.TAPPING SCREW SCREW	
4	P6625010650	1	中間蓋(超黑)	MIDDLE COVER	
5	P6625301000	1	左車身蓋	LH BODY COVER	ADD COLOR CODE
6	P6625501000	1	右車身蓋	RH BODY COVER	ADD COLOR CODE
7	92370500003	7	U型彈簧螺帽	SPRING NUT U-TYPE	
8	92040800000	1	六角凸緣螺帽	HEXAGON FLANGE NUT	
9	P566G0110002	1	左後方向燈組合(透明燻黑)	LH RR SIGNAL LAMP ASSY(WHITE)	
10	P566G0200002	1	左後方向燈蓋(透明燻黑)	LH RR SIGNAL LAMP COVER(WHITE)	
11	P566H0110002	1	右後方向燈組合(透明燻黑)	RH RR SIGNAL LAMP ASSY(WHITE)	
12	P566H0200002	1	右後方向燈蓋(透明燻黑)	RH RR SIGNAL LAMP COVER(WHITE)	
13	90110401200	4	自攻螺絲	C-R RECESS PAN HD.TAPPING SCREW SCREW	
14	P6625700000	1	後蓋	REAR COVER	ADD COLOR CODE
15	P66760007J0	1	後行李架(晶鑽銀)	RR LUGGAGE BRACKET(SILVER)	
16	90190802000	2	六角凸緣螺栓	HEXAGON FLANGE BOLT	
17	P6625600000	1	左後方向燈飾蓋	LH REAR TURN SIGNAL,INNER COVER	
18	P6676010000	1	後行李架飾蓋	RR LUGGAGE BRACKET COVER	
19	P6625F00000	1	右後方向燈飾蓋	RH REAR TURN SIGNAL,INNER COVER	
20	90040601400	2	十字槽盤頭機器螺釘	C-R RECESS PAN HD.TAPPING SCREW SCREW	
21	90130501400	2	自攻螺絲	C-R RECESS PAN HD.TAPPING SCREW SCREW	
22	98211210990	2	燈泡(12V/10W橘黃色)	BULB(ORANGE)	
23	90110401200	1	自攻螺絲	C-R RECESS PAN HD.TAPPING SCREW SCREW	

F9 **BUBU**  
SEAT.LUGGAGE.TOOL KIT.  
LUGGAGE LOW COVER

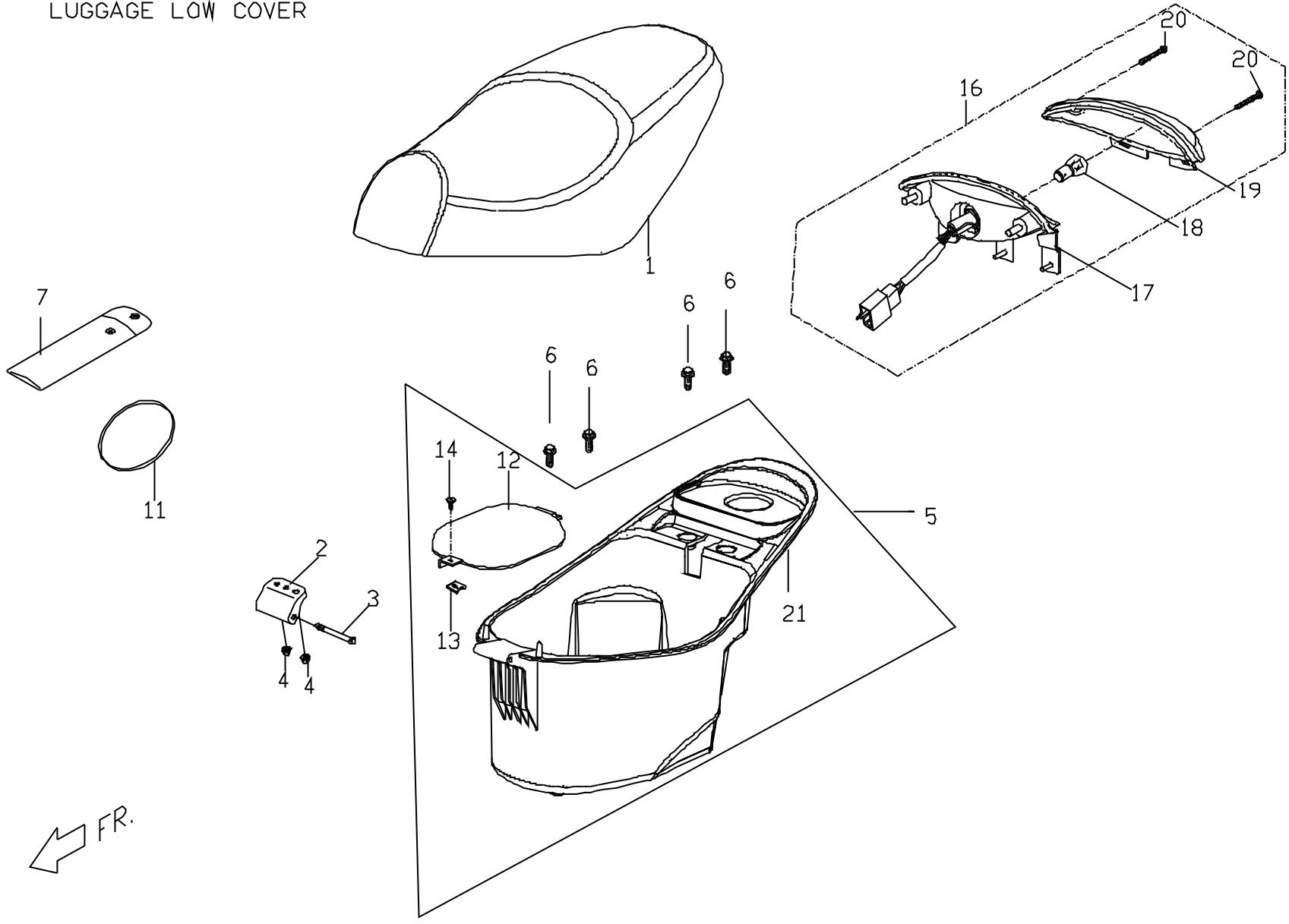

FR.



F10

**BUBU**  
LICENSE PLATE, REFLECTOR,  
LICENCE LAMP

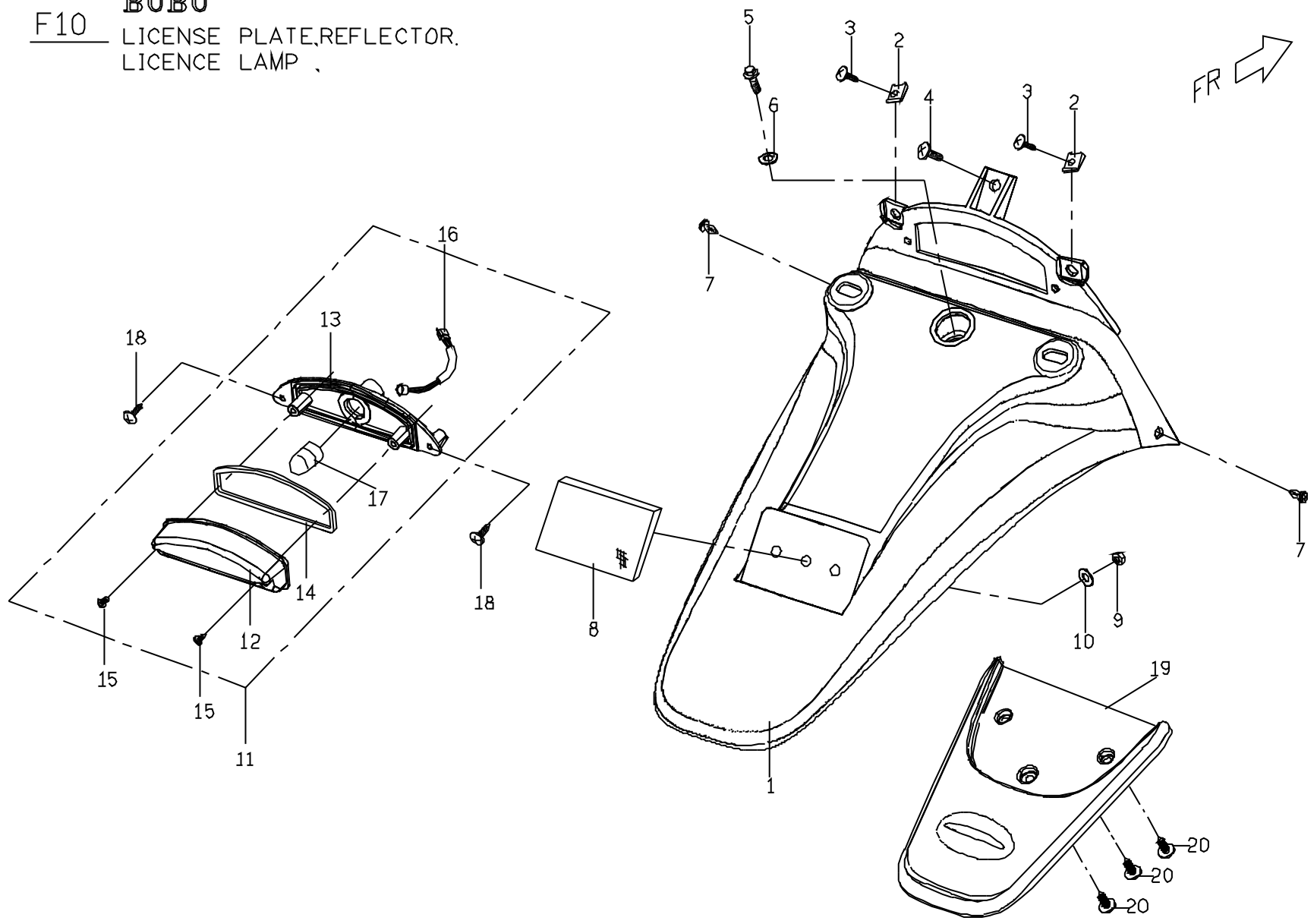

## F10. PA125\_LICENSE PLATE

No.	Part No.	Q'TY	PART NAME	PART NAME	REMARK
項目	零件號碼	數量	零件中文名稱	零件英文名稱	備註
1	P5636003650	1	牌照板(超黑)	LICENCE PLATE	
2	92370500003	2	U型彈簧螺帽	SPRING NUT U-TYPE	
3	90150501601	2	自攻螺絲	TAPPING SCREW	
4	90130501400	1	自攻螺絲	TAPPING SCREW	
5	90040601400	1	十字槽圓頭自攻螺釘	C-R RECESS PAN HD TAPPING SCREW	
6	92140600005	1	墊圈	WASHER	
7	E1701040000	2	螺旋鉚釘組合	SCRIVET COMP	
8	P5669000000	1	反光片	REFLECTOR	
9	92020500000	1	六角螺帽	HEXAGON NUT	
10	92140500014	1	墊圈	WASHER	
11	P5666900000	1	牌照燈組合	LICENCE LAMP ASSY	
12	P566F910000	1	燈殼	LAMP COVER	
13	P566F920000	1	底座	SOCKET	
14	P566F930000	1	迫緊墊	PACKING	
15	P566F940000	1	自攻螺絲	TAPPING SCREW	
16	P566F950000	1	電線組	CONNECTING WIRE	
17	P566F960000	1	燈泡(12V-5W)	BULB(12V-5W)	
18	90110401200	1	自攻螺絲	TAPPING SCREW	
19	P6636010650	1	牌照板下段(超黑)	LICENCE PLATE LOWER PART	
20	90110401200	3	自攻螺絲	TAPPING SCREW	

F11 BUBU  
FUEL TANK

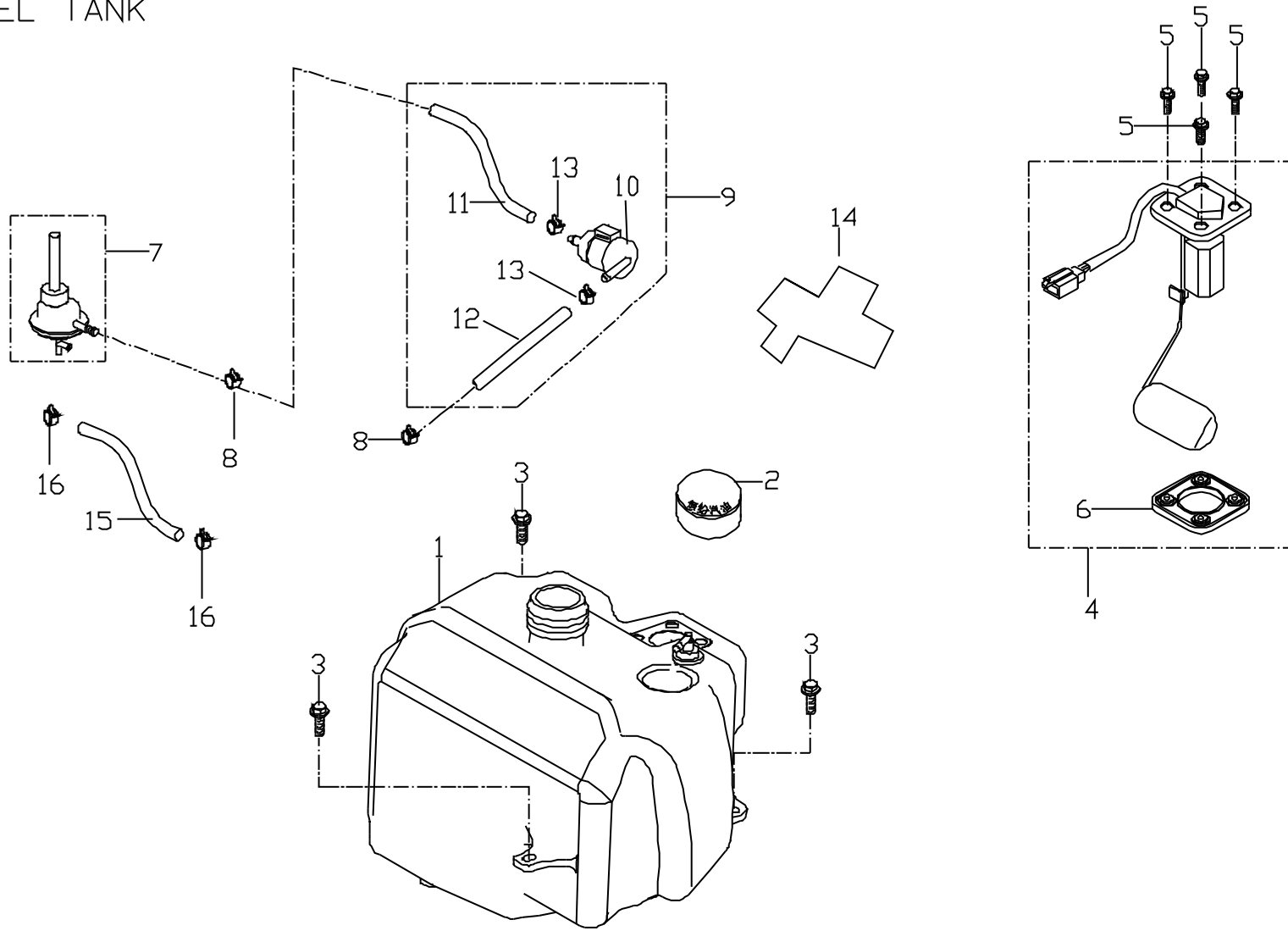

FR.



F12.2 **BUBU**  
FRAME (FOR BUBU100/125)

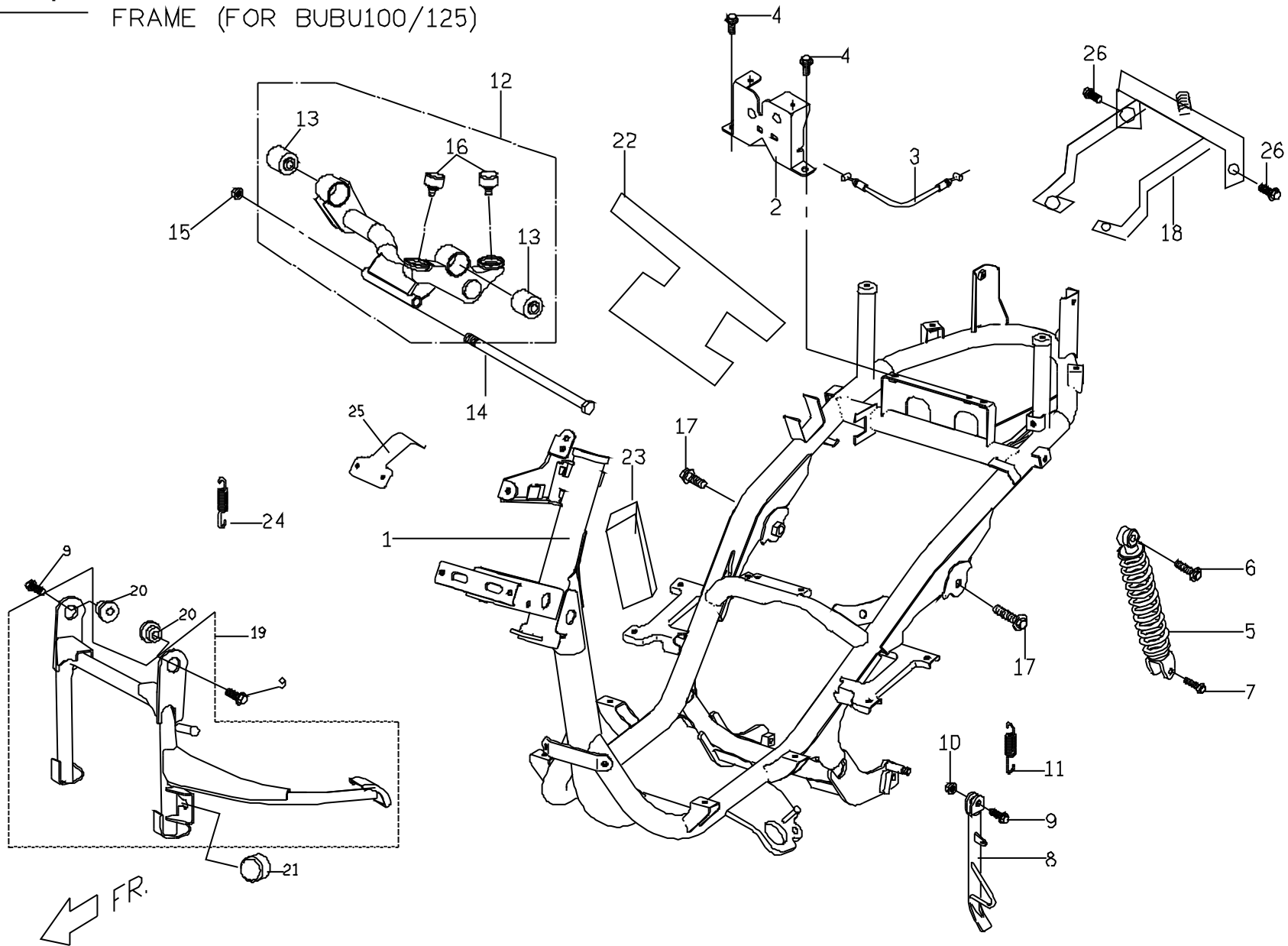

## F12. PA125\_FRAME

No.	Part No.	Q'TY	PART NAME	PART NAME	REMARK
項目	零件號碼	數量	零件中文名稱	零件英文名稱	備註
1	P642A0016001	1	車架總成(E.D)	FRAME COMP	
2	P5671300000	1	座墊鎖座組合	SEAT LOCK COMP	
3	P5671121000	1	座墊鎖拉桿線	SEAT LOCK LEVER CABLE	
4	90160601500	2	六角凸緣螺栓(M6*15)	HEXAGON FLANGE BOLT	
5	P6481001000	1	後緩衝器總成(黑色)	CUSHION ASSY,RR.(BLACK)	
6	90191004000	1	六角凸緣螺栓(M10*40)	HEXAGON FLANGE BOLT	
7	90190803201	1	六角凸緣螺栓	HEXAGON FLANGE BOLT	
8	P6462000600	1	側腳柱總成(E.D)	SIDE STAND COMP(FIXED)	
9	90191002800	3	六角凸緣螺栓	HEXAGON FLANGE BOLT	
10	92061000000	1	U型螺帽	U TYPE NUT	
11	C2462120000	1	側腳柱彈簧	SIDE STAND SPRING	
12	C1486003000	1	引擎吊架本體熔接組合	ENGINE HANGER COMP	
13	C1486010000	2	緩衝襯套	CUSHION RUBBER	
14	90191018000	1	六角頭螺栓	HEXAGON BOLT	
15	92061000001	1	防鬆螺帽	LOCK NUT	
16	C1486050000	2	防震橡膠	RUBBER,DAMPER	
17	90191005500	2	六角凸緣螺栓(M10*55L)	HEXAGON FLANGE BOLT(M10*55L)	
18	P6421500600	1	汽油箱支撐板(E.D)	FUEL TANK BRACKET	
19	P6461002600	1	中腳柱組合(E.D)	CENTER STAND COMP	
20	C2461010000	2	襯套	BUSH	
21	C1701050000	1	中腳柱緩衝橡膠	RUBBER DAMPING,CENTER STAND	
22	P6701020000	1	防水護墊	WATER RESISTANT RUBBER	
23	P64260200005	1	車輛識別號碼牌	VIN PLATE	
24	E1461120000	1	中柱彈簧	MAIN STAND SPRING	
25	P6421411600	1	擋風板連接板	WINDSHIELD BRACKET	
26	90190601500	2	六角凸緣螺栓	HEXAGON FLANGE BOLT	

F13 **BUBU**  
WIRE HARNESS

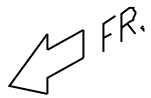
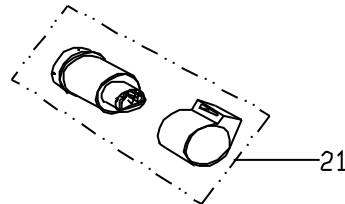
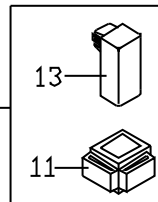
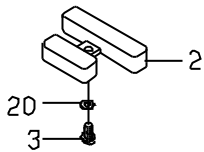
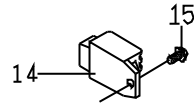
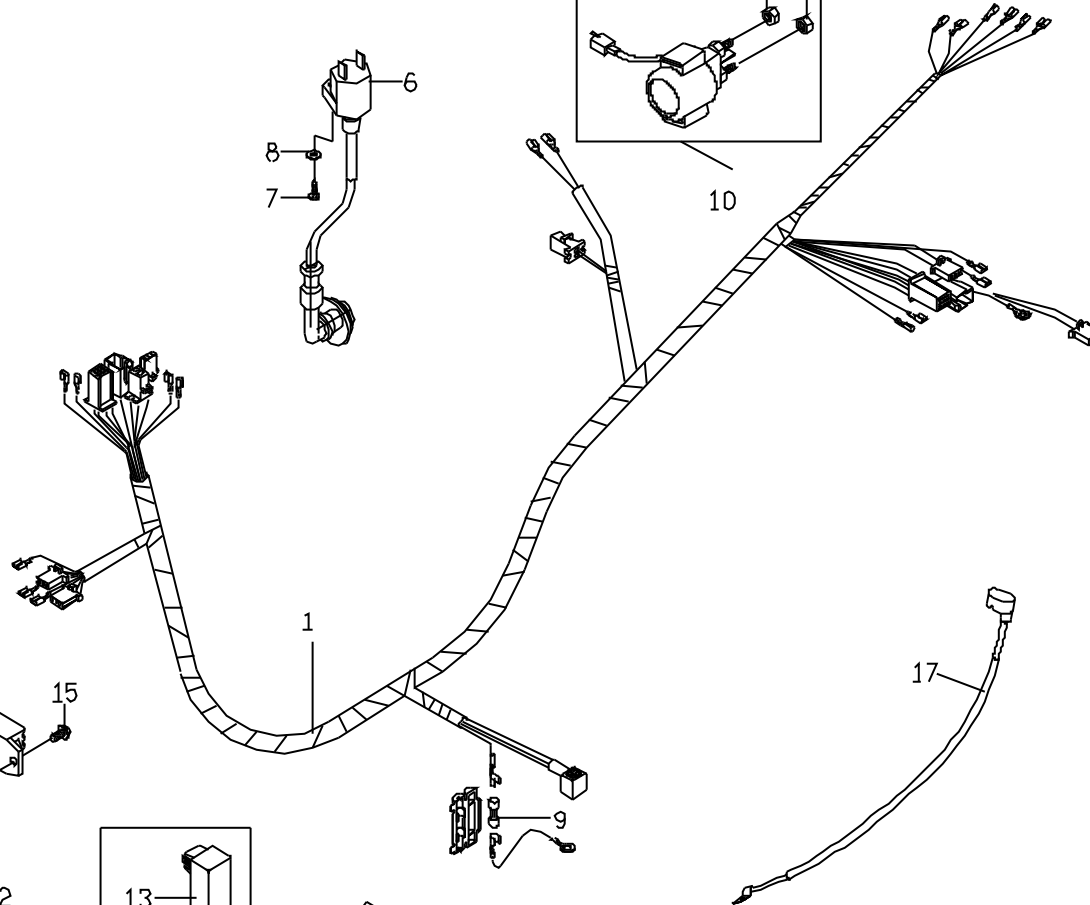
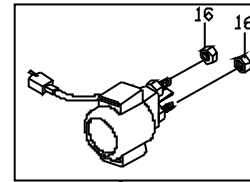
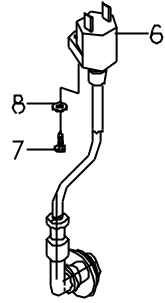
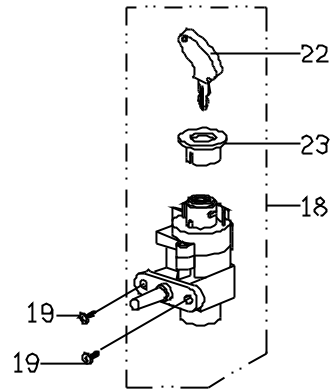

## F13. PA125\_WIRE HARNESS

No.	Part No.	Q'TY	PART NAME	PART NAME	REMARK
項目	零件號碼	數量	零件中文名稱	零件英文名稱	備註
1	P6581602000	1	主配線總成	WIRE HARNESS	
2	P65866000001	1	電阻器A	RESISTOR A	
3	90190601200	1	六角凸緣螺栓(M6*12L)	HEXAGON FLANGE BOLT	
4	P5583600000	1	喇叭	HORN	
5	90190601200	1	六角凸緣螺栓(M6*12L)	HEXAGON FLANGE BOLT	
6	C1584601000	1	點火線圈總成	COIL COMP,IGNITION	
7	90070502000	1	十字槽扁圓頭機器螺釘	C-R MACHINE HD,TAPPING SCREW	
8	92110500000	1	彈簧鎖緊墊圈	SPRING LOCK WASHER	
9	C158A020000	1	保險絲	FUSE	
10	C1581001000	1	起動繼電器總成	STARTER RELAY AND SUPPORTOR ASSY	
11	C1701200000	1	橡膠托架	RUBBER BRACKET	
12	C1582001000	1	電子點火控制器總成	CDI UNIT ASSY	
14	C1584000000	1	電壓調整器總成(交流)	VOL REGULATOR COMP	
15	90190601500	2	六角凸緣螺栓	HEXAGON FLANGE BOLT	
16	92030600004	2	六角螺帽	HEXAGON NUT	
17	P6583020000	1	電瓶正極線	BATTERY (+)LINE	
18	P5552002000	1	電源鎖總成	IGNITION SWTTCH ASSY	
19	90040601601	1	十字槽盤頭機器螺釘	C-R MACHINE HD,TAPPING SCREW	
20	92130600000	1	齒形墊圈	TEETH WASHER	
21	P2586011000	1	方向繼電器總成	FLASHER RELAY ASSY	
22	P555B011000	1	鑰匙	DUMMY KEY	
23	P555B020000	1	面板	INDICATOR PLATE	

# F14 LABELS\_PA125

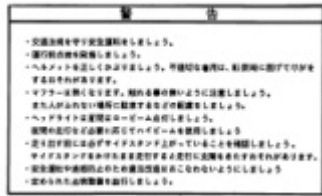

1

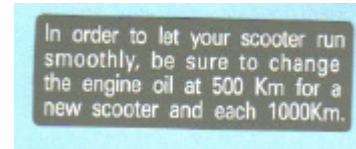

5



2



6



3



7

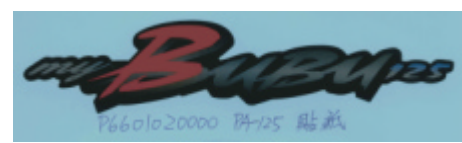

4

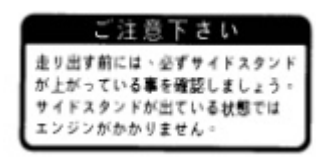

8

P6601190000



9

