

DINK 125 Wiring Diagram

WIRE COLORS

(GROUND/MARKING)

- B: BLACK
- G: GREEN
- L: BLUE
- O: ORANGE
- R: RED
- V: VIOLET
- W: WHITE
- Y: YELLOW
- BR: BROWN
- GR: GRAY
- LG: LIGHT GREEN
- SB: SKY BLUE

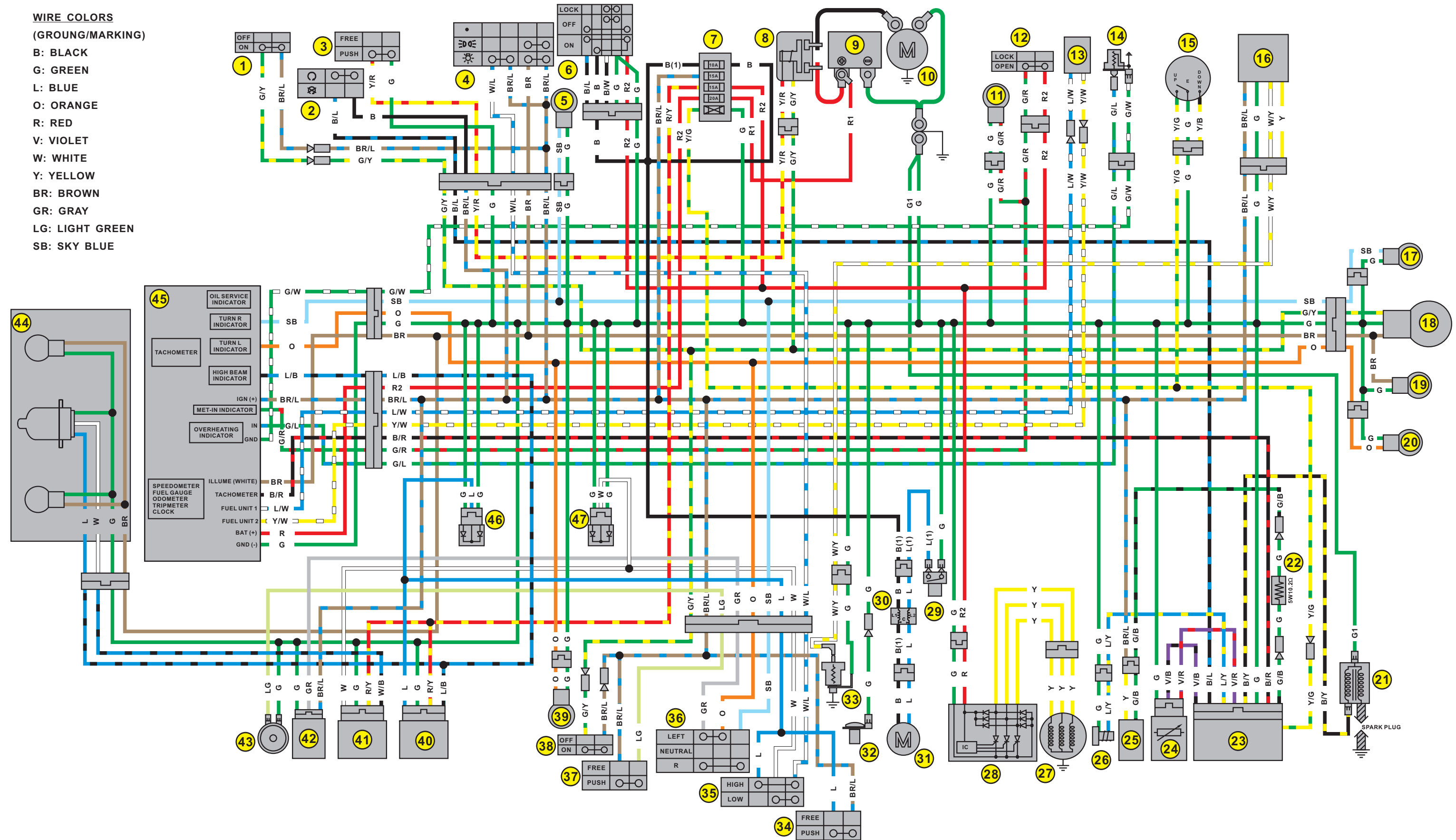

- 1 FRONT BRAKE LIGHT SWITCH
- 2 ENGINE STOP SWITCH
- 3 STARTER SWITCH
- 4 HEADLIGHT/POSITION LIGHT SWITCH
- 5 FRONT RIGHT TURN SIGNAL LIGHT
- 6 IGNITION SWITCH
- 7 FUSE BOX
- 8 STARTER MOTOR RELAY

- 9 BATTERY
- 10 STARTER MOTOR
- 11 LUGGAGE BOX LIGHT
- 12 LUGGAGE BOX LIGHT SWITCH
- 13 FUEL UNIT
- 14 OVERHEATING SENSOR
- 15 SIDE STAND SWITCH
- 16 HEATER CONTROLLER

- 17 REAR RIGHT TURN SIGNAL LIGHT
- 18 TAILLIGHT/BRAKE LIGHT
- 19 LICENCE LIGHT
- 20 REAR LEFT TURN SIGNAL LIGHT
- 21 IGNITION COIL
- 22 RESISTER
- 23 CDI
- 24 TPS

- 25 AUTO CHOKE
- 26 PULSER
- 27 A.C.G
- 28 REGULATOR/RECTIFIER
- 29 COOLING FAN MOTOR SWITCH
- 30 EMI FILTER
- 31 COOLING FAN MOTOR
- 32 FUEL FILL CAP GROUND

- 33 CARBURETOR HEATER
- 34 PASSING LIGHT SWITCH
- 35 DIMMER SWITCH
- 36 TURN SIGNAL LIGHT SWITCH
- 37 HORN SWITCH
- 38 REAR BRAKE LIGHT SWITCH
- 39 FRONT LEFT TURN SIGNAL LIGHT
- 40 HIGH BEAM RELAY

- 41 LOW BEAM RELAY
- 42 FLASHING RELAY
- 43 HORN
- 44 HEADLIGHT/POSITION LIGHT
- 45 INSTRUMENT & INDICATORS
- 46 DIODE (HIGH BEAM)
- 47 DIODE (LOW BEAM)