

序號	零件號碼	中文名稱	規格	配賦量	售價 (含稅)	備註
				HD-125C		
No.:	Part No.:	Name	Spec.	Q'ty	Price	Remark
03	1240103002	汽缸	有烤	1	1114	
04	1540104001	汽缸墊片		1	21	
05	1240105005	汽缸頭		1	2714	
06	1240106001	汽缸頭墊片		1	96	
07	1240107000	汽缸頭蓋	(銀)	1	407	
08	1240108000	汽缸頭蓋墊圈		1	80	
29	1540109000	進氣歧管		1	411	
30	1240109100	歧管間隔板		1	42	
33	1240133000	歧管間隔板墊片		2	11	

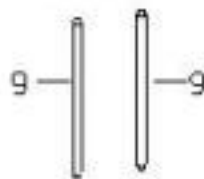

序號	零件號碼	中文名稱	規格	配賦量	售價 (含稅)	備註
				HD-125C		
No.:	Part No.:	Name	Spec.	Q'ty	Price	Remark
01	1240201000	門閥徑封		2	36	
02	1240202000	推桿導板		1	25	
04	1240204001	搖臂座組		1	667	
05	1240205001	從動凸輪		2	193	
06	1540206001	從動凸輪軸		1	126	
07	1540207001	凸輪齒輪軸		1	111	
09	1240209000	推桿		2	212	
10	1240210000	吸氣門閥		1	212	
11	1240211000	排氣門閥		1	373	
12	1240212000	門閥外彈簧		2	48	

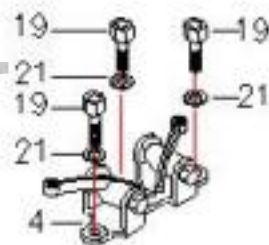
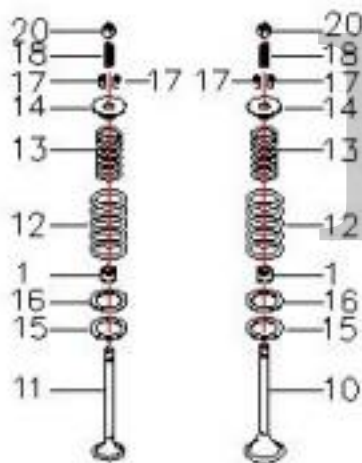
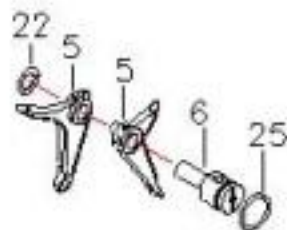
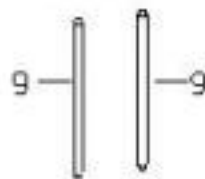
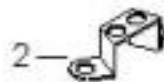
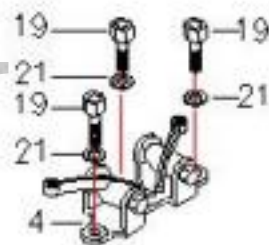
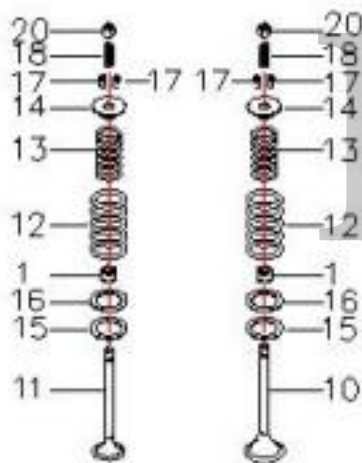
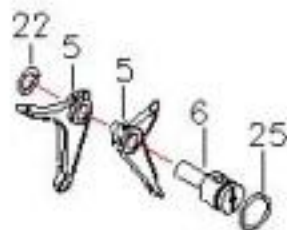

序號	零件號碼	中文名稱	規格	配賦量	售價 (含稅)	備註
				HD-125C		
No.:	Part No.:	Name	Spec.	Q'ty	Price	Remark
13	1240213000	門閥內彈簧		2	29	
14	1240214000	門閥彈簧承盤		2	38	
15	1240215000	門閥外彈簧座		2	4	
16	1240216000	門閥內彈簧座		2	4	
17	1240217000	門閥栓		4	11	

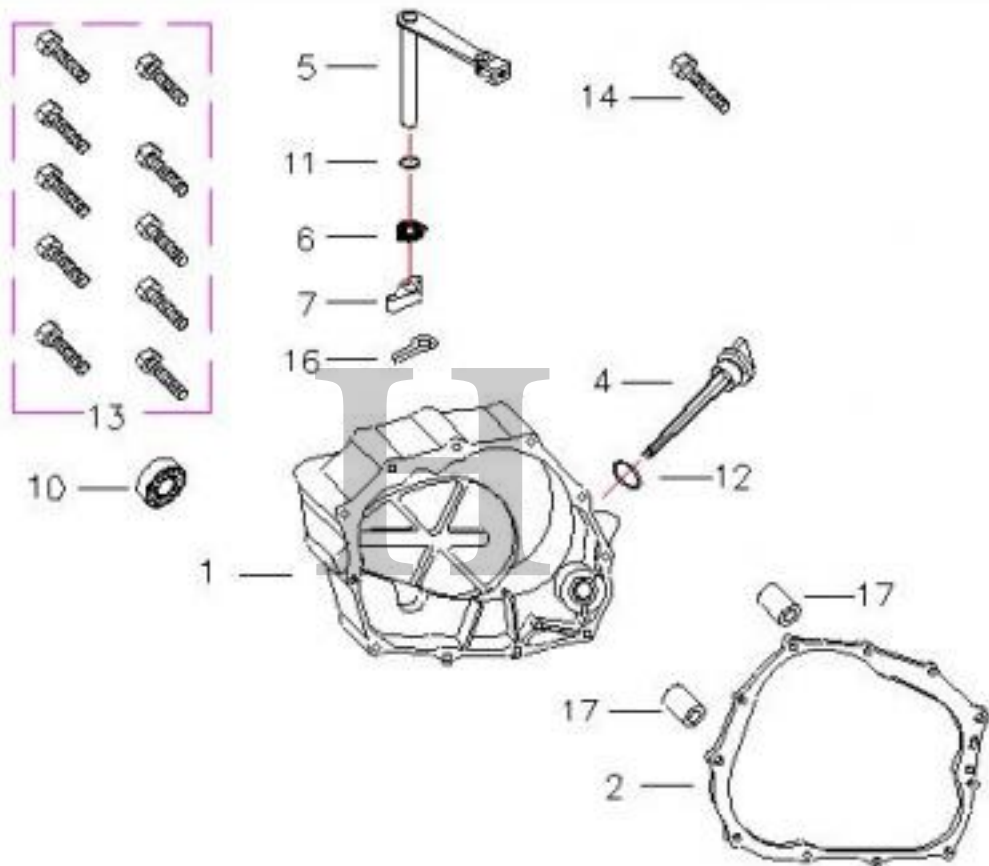

序號	零件號碼	中文名稱	規格	配賦量	售價 (含稅)	備註
				HD-125C		
No.:	Part No.:	Name	Spec.	Q'ty	Price	Remark
01	1240301009	右曲軸箱蓋	HD/Taiwan	1	1011	
02	1240302001	右曲軸箱蓋墊片		1	76	
04	1240304001	量油尺		1	36	
05	1240305000	離合器拉桿		1	107	
06	1240306000	離合器拉桿彈簧		1	6	
07	1240307000	離合器舉動凸輪		1	15	
10	9120425900	油封	16*28*7	1	15	
11	9130102700	O環	φ 6.8* φ 1.9	1	4	
12	9130703500	O環	φ 18* φ 3	1	6	

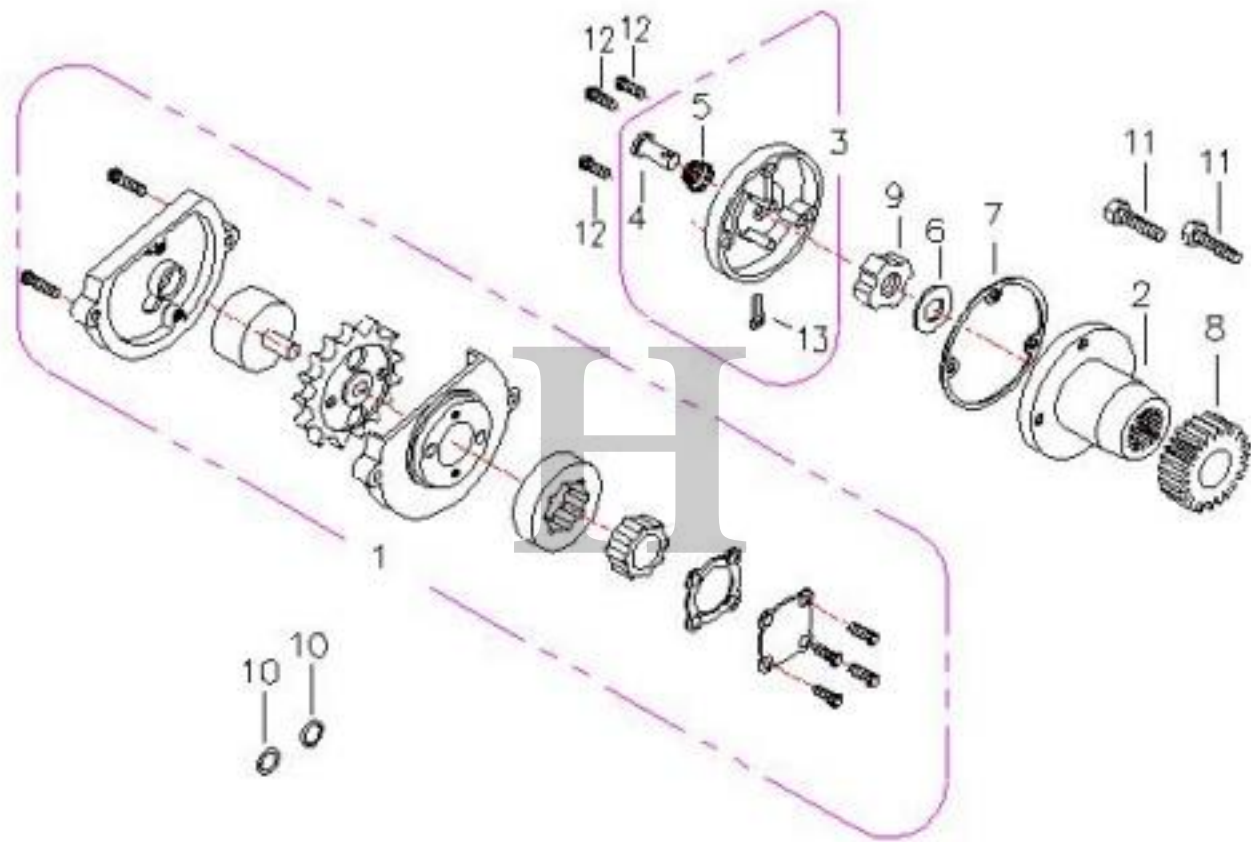

序號	零件號碼	中文名稱	規格	配賦量	售價 (含稅)	備註
				HD-125C		
No.:	Part No.:	Name	Spec.	Q'ty	Price	Remark
01	1240401003	機油泵	HD/Taiwan	1	252	
02	1240402002	濾油網轉子組		1	180	
02	1240402003	濾油網轉子		1	96	
03	1240403001	濾油網轉子蓋		1	55	
07	1240407001	濾油網轉子蓋墊片		1	15	
08	1240408000	第一驅動齒輪		1	189	

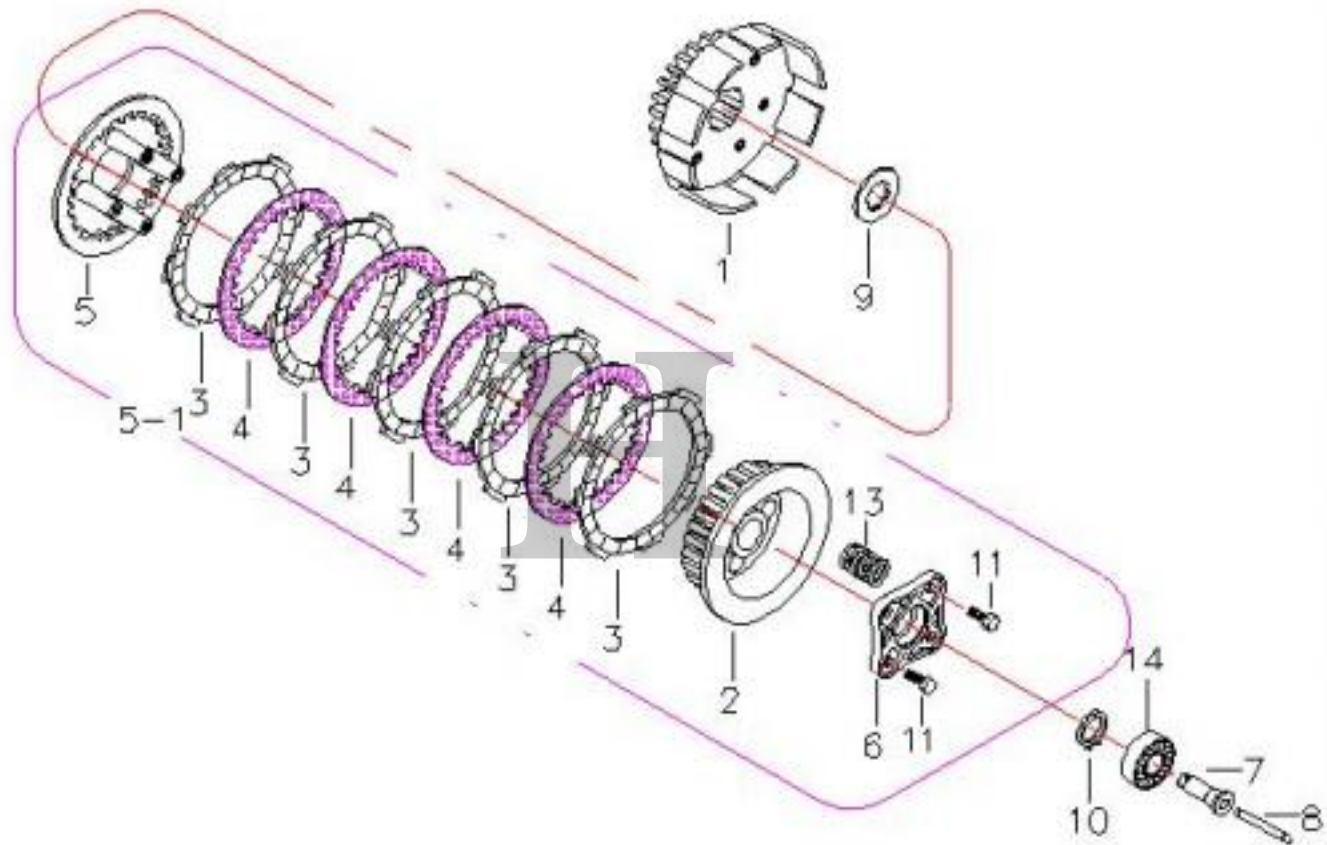

序號	零件號碼	中文名稱	規格	配賦量	售價 (含稅)	備註
				HD-125C		
No.:	Part No.:	Name	Spec.	Q'ty	Price	Remark
01	1240501004	離合器外套		1	453	
02	1240502001	離合器中心板		1	147	
03	1240503001	離合器摩擦板		5	42	
04	1240504001	離合器板		4	21	
05	1240505001	離合器壓力板		1	166	
05-1	1240501003	離合器總成		1	1063	
06	1240506001	離合器舉升板		1	42	
07	1240507000	離合器舉升導銷		1	54	
08	1240508000	離合器舉動桿		1	19	
13	1240513001	離合器彈簧		4	11	
14	9610060010	軸承	6001	1	78	

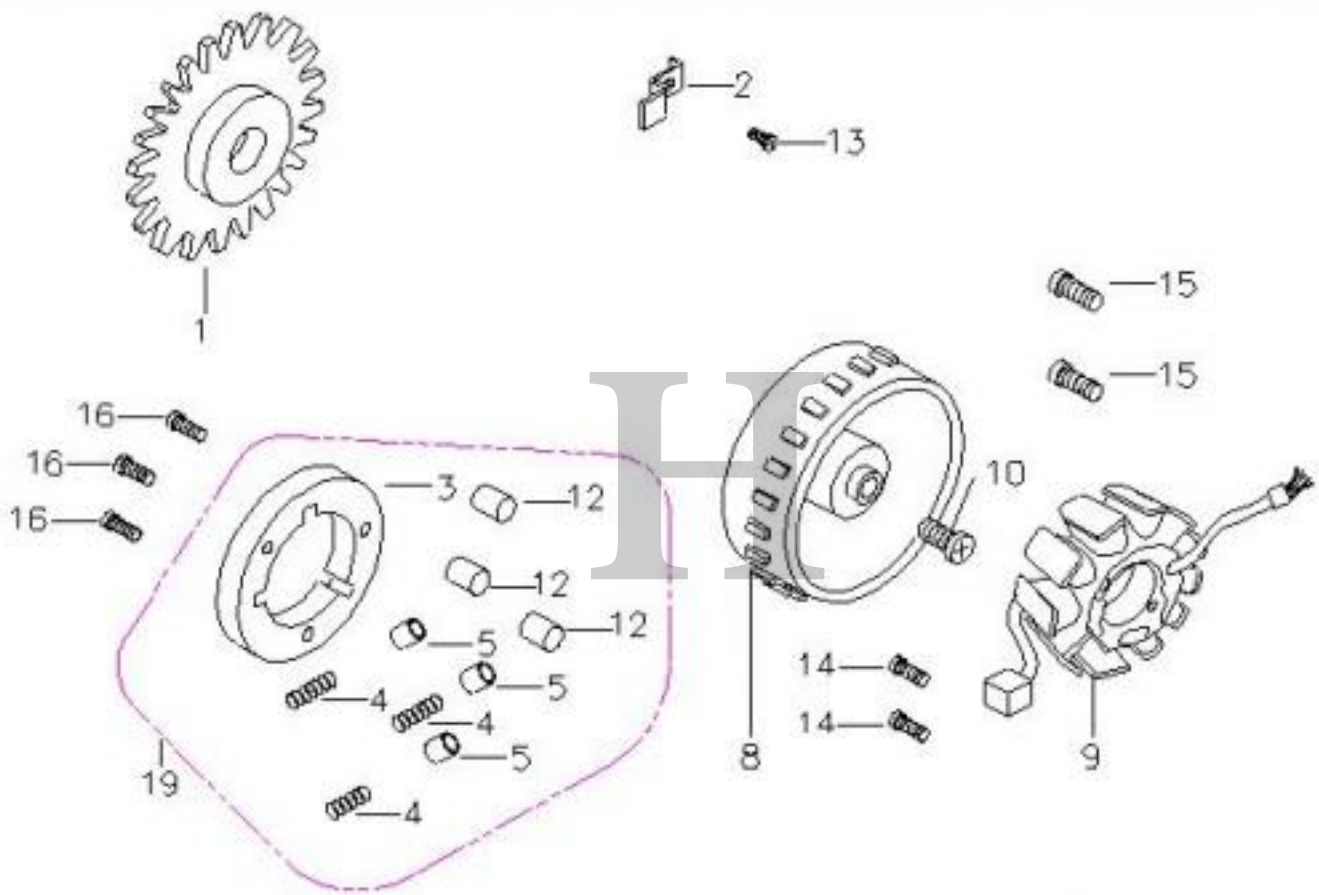

序號	零件號碼	中文名稱	規格	配賦量	售價 (含稅)	備註
				HD-125C		
No.:	Part No.:	Name	Spec.	Q'ty	Price	Remark
01	1240601001	起動齒輪		1	505	
02	1240602000	齒輪固定板		1	21	
04	1240604000	滾子彈簧		3	11	
05	1240605000	滾子彈簧蓋		3	15	
08	1240608002	飛輪	多點式(23點)	1	1420	
09	1240609003	轉子線圈	三相	1	1540	
12	1240612000	滾子	10*10	3	15	
19	1240603002	起動離合器外套組		1	531	

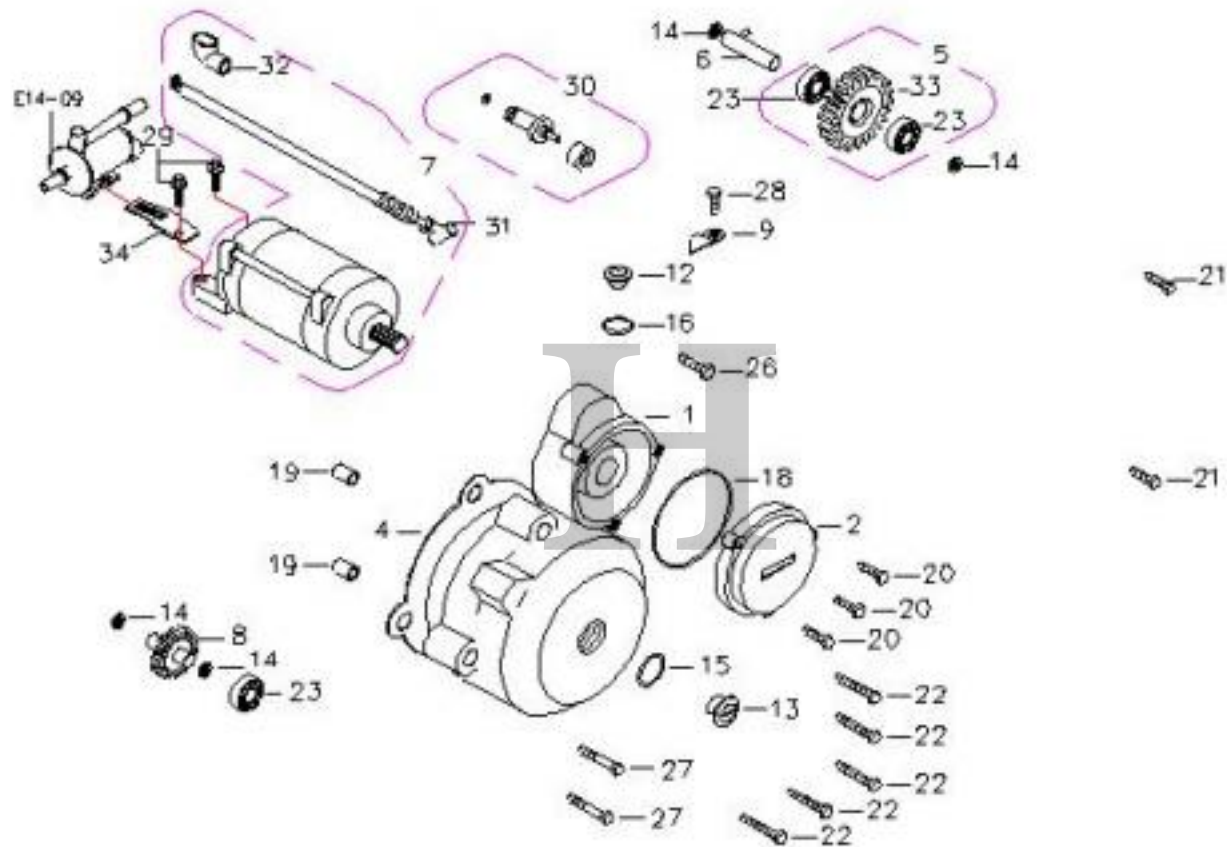

序號	零件號碼	中文名稱	規格	配賦量	售價 (含稅)	備註
				HD-125C		
No.:	Part No.:	Name	Spec.	Q'ty	Price	Remark
01	1240701000	左曲軸箱蓋	HARTFORD(painting)	1	696	
02	1240702002	減速齒輪蓋	H	1	118	
04	1240704001	左曲軸箱蓋墊片		1	59	
05	1240705010	減速齒輪組		1	499	
06	1240706000	減速齒輪軸		1	71	
07	1240707002	起動馬達組	HD125K	1	1590	
08	1240708001	起動齒輪組		1	235	
12	1240712002	A.C.G 蓋		1	25	
13	1240713002	蓋	30MM	1	46	
23	9102114800	滾針軸承	1010	3	61	

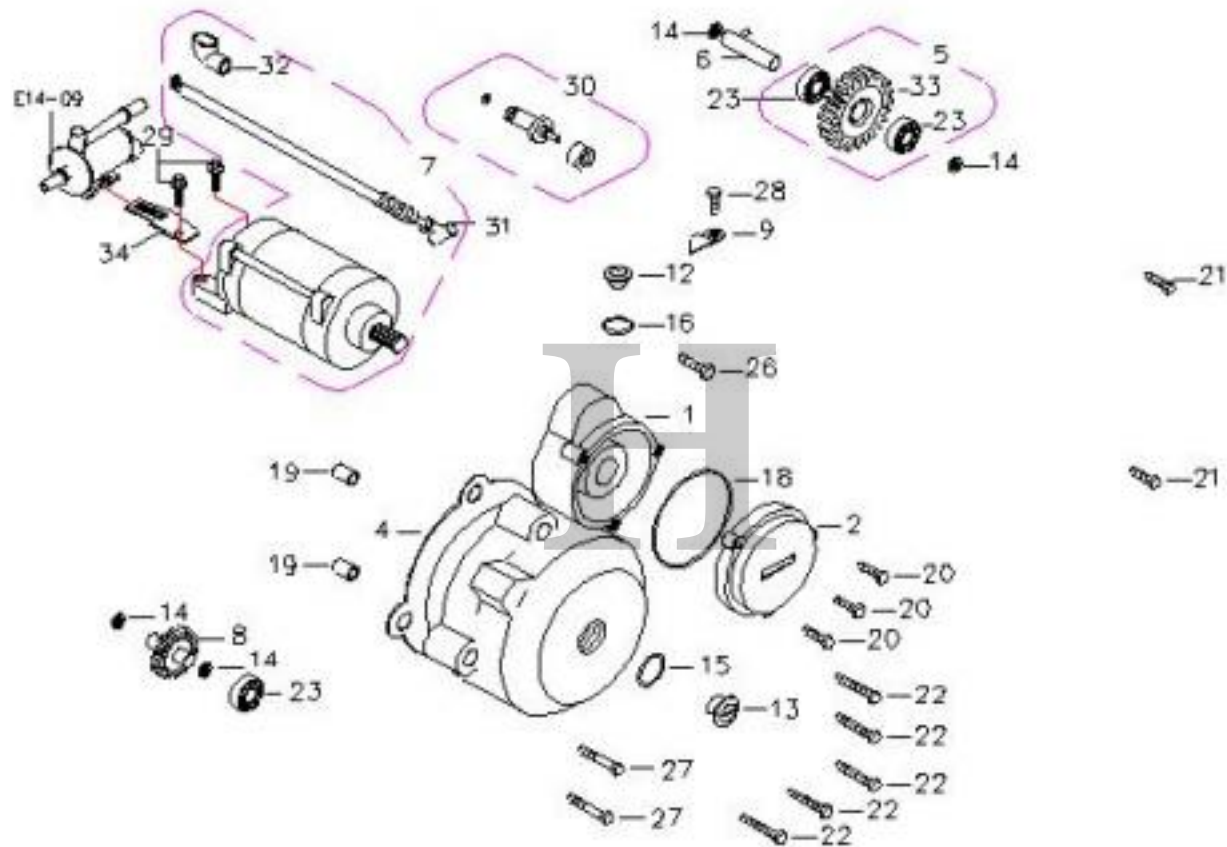

序號	零件號碼	中文名稱	規格	配賦量	售價 (含稅)	備註
				HD-125C		
No.:	Part No.:	Name	Spec.	Q'ty	Price	Remark
30	1240730001	空檔燈開關組		1	65	
31	1240731002	馬達導線	HD-125K	1	185	
34	1240734000	怠速控制器固定板		1	17	

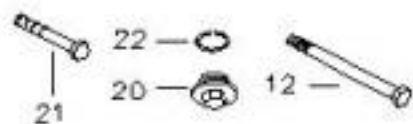
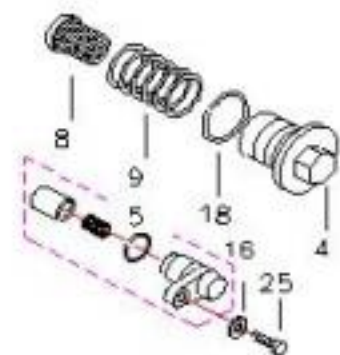
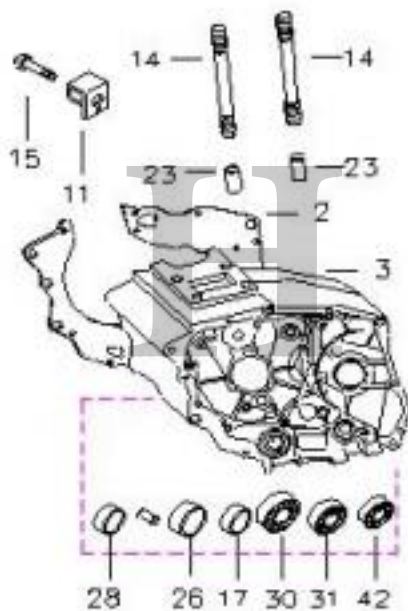

序號	零件號碼	中文名稱	規格	配賦量	售價 (含稅)	備註
				HD-125C		
No.:	Part No.:	Name	Spec.	Q'ty	Price	Remark
01	1540801100	右曲軸箱		1	1707	
02	1540802001	曲軸箱墊片		1	101	
04	1240804001	左濾油網蓋		1	34	
05	1240805002	推栓固定座組	ASSY	1	161	
08	1240808001	濾油網		1	34	
09	1240809000	濾油網彈簧		1	6	
11	1240811000	離合器導線固定座		1	21	
17	9120628600	油封	14*28*7	1	13	
18	9130310700	O-環	φ 35* φ 3	1	8	
26	9120539300	油封	34*50*7	1	25	

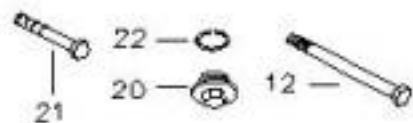
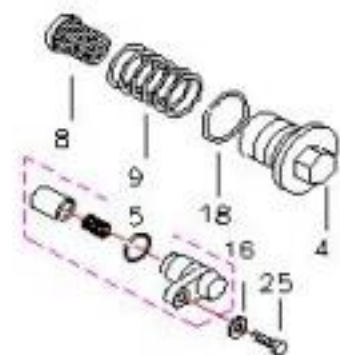
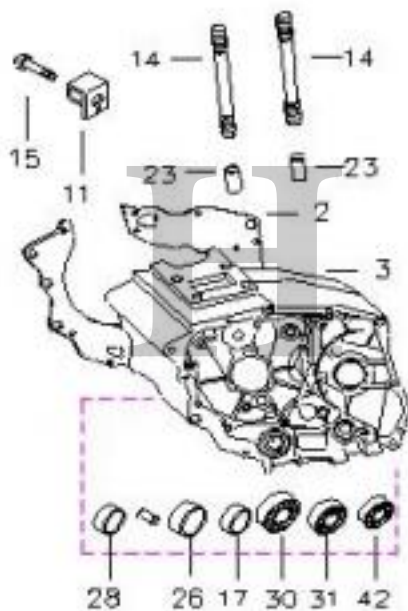

序號	零件號碼	中文名稱	規格	配賦量	售價 (含稅)	備註
				HD-125C		
No.:	Part No.:	Name	Spec.	Q'ty	Price	Remark
27	9110638300	滾針軸承	1512	1	76	
28	9120103000	油封	20*34*7	1	19	
29	9610060060	軸承	6006	1	155	
30	9612062020	軸承	6202Z	1	76	
31	9610062040	軸承	6204	1	111	
42	9102114800	滾針軸承	1010	1	61	

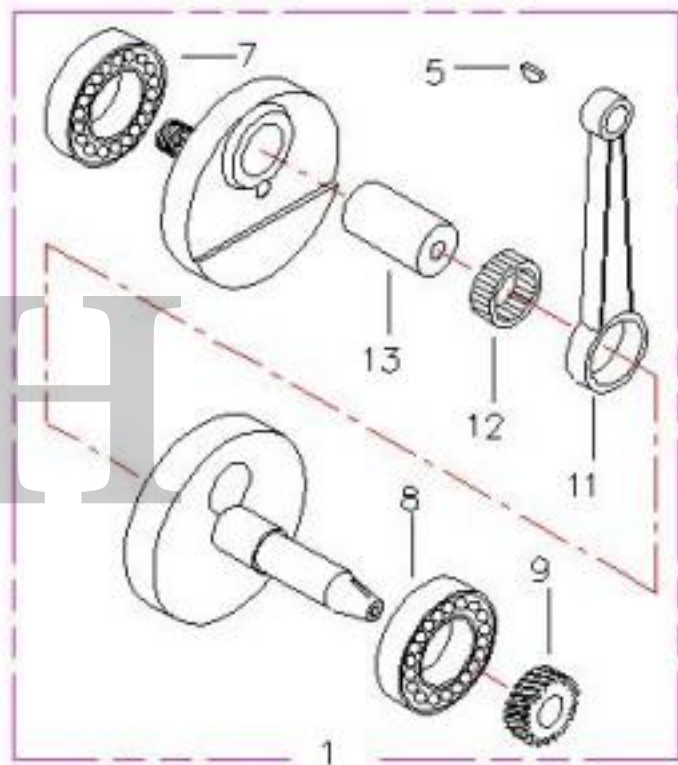

序號	零件號碼	中文名稱	規格	配賦量	售價 (含稅)	備註
				HD-125C		
No.:	Part No.:	Name	Spec.	Q'ty	Price	Remark
01	1240901001	曲軸		1	2668	
02	1240902000	活塞	STANDARD (125c.c)	1	243	
03	1240903000	活塞銷	125c.c	1	42	
04	1240904000	活塞環組	STANDARD (125c.c)	1	231	
05	9440125140	月形固定片	4MM	1	19	
06	1240906000	活塞銷夾	φ 15	2	4	
07	1240907000	軸承	6328J	1	331	
08	1240908000	軸承	6328U	1	376	

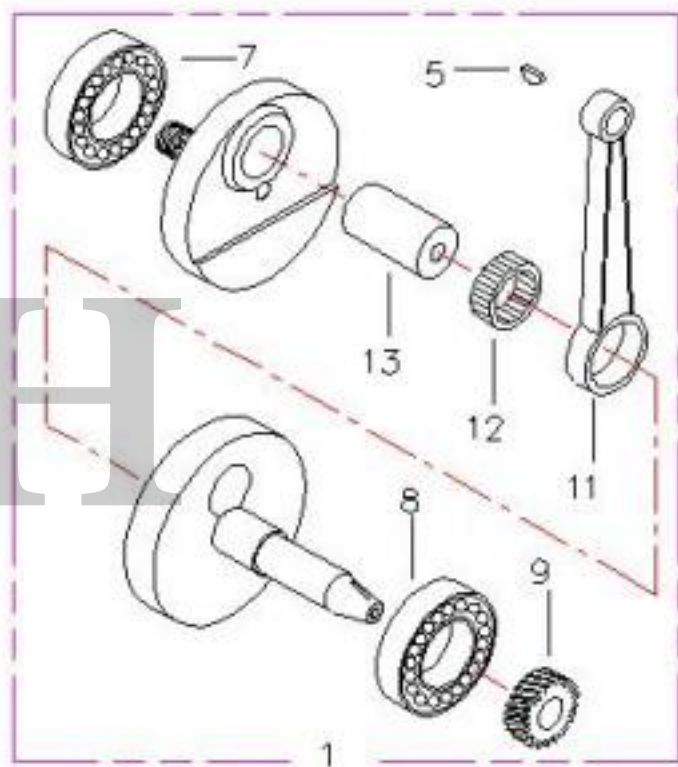

序號	零件號碼	中文名稱	規格	配賦量	售價 (含稅)	備註
				HD-125C		
No.:	Part No.:	Name	Spec.	Q'ty	Price	Remark
09	1240909000	定時齒輪	H	1	185	
10	1240910000	凸輪軸組		1	589	
11	1240911000	連桿		1	285	
12	1240912000	連桿軸承		1	176	
13	1240913000	曲柄銷		1	212	

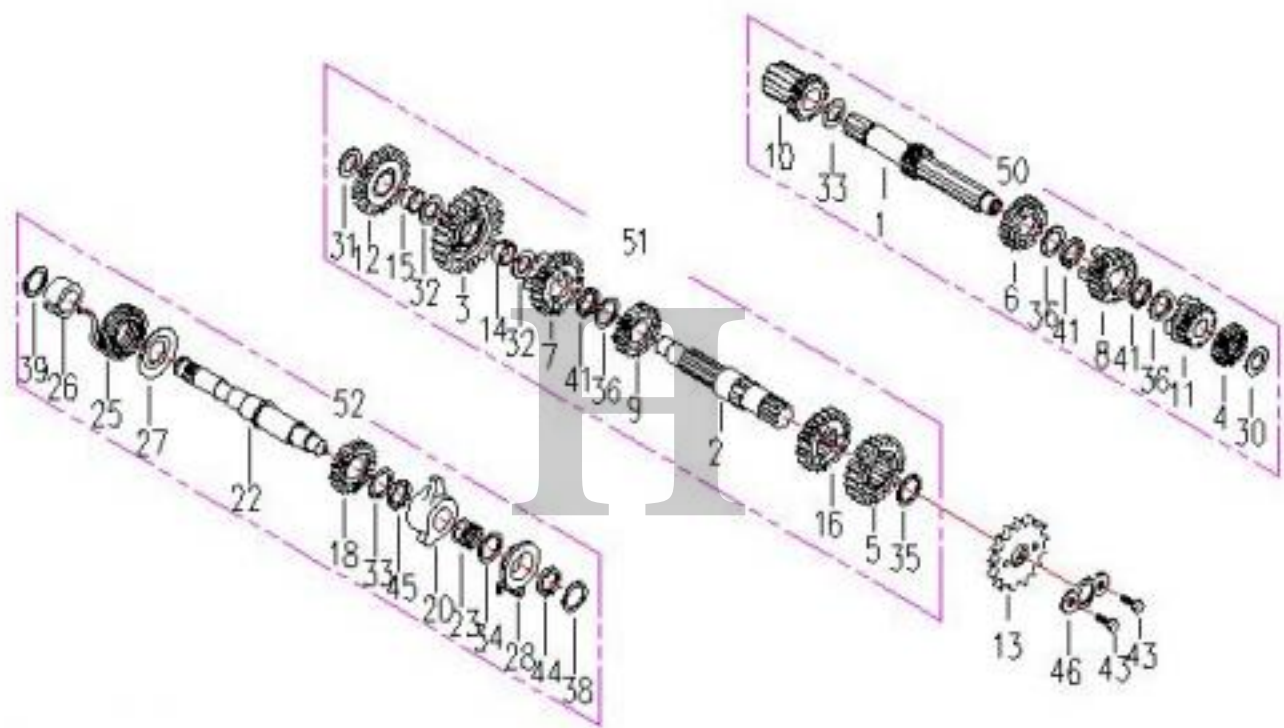

序號	零件號碼	中文名稱	規格	配賦量	售價 (含稅)	備註
				HD-125C		
No.:	Part No.:	Name	Spec.	Q'ty	Price	Remark
13	1241013001	驅動齒輪-16T	150c.c	1	126	
46	1241046000	固定板 A2		1	11	
50	1251050002	主傳動齒輪組	5-speed, 25T	1	1666	
51	1251051003	副傳動齒輪組	5-speed, gear 24T	1	1716	
52	1251052001	起動桿組		1	875	

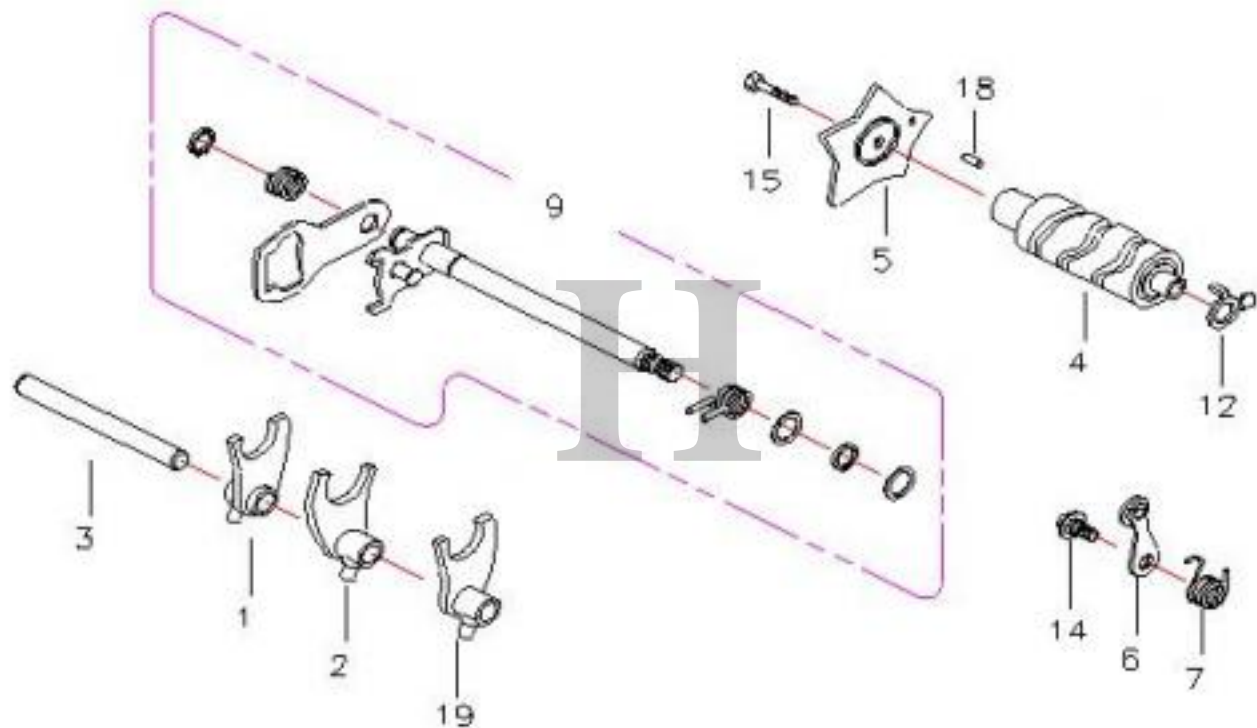

序號	零件號碼	中文名稱	規格	配賦量	售價 (含稅)	備註
				HD-125C		
No.:	Part No.:	Name	Spec.	Q'ty	Price	Remark
01	1241101001	齒輪變速右叉		1	248	
02	1241102001	齒輪變速中叉		1	248	
03	1241103001	變速叉樞軸		1	46	
04	1251104002	齒輪變速鼓輪	5-speed(Nation)	1	541	
05	1251105000	齒輪變速凸輪	5-speed(Nation)	1	50	
06	1241106002	變速鼓輪制止板	5-speed(Nation)	1	38	
07	1241107000	制止板彈簧	5-speed(Nation)	1	15	
09	1241109002	齒輪變速板總成	HD/Taiwan(5-speed)	1	269	
12	1251112000	空速開關轉子		1	17	
19	1251119001	齒輪變速左叉	5-speed	1	248	

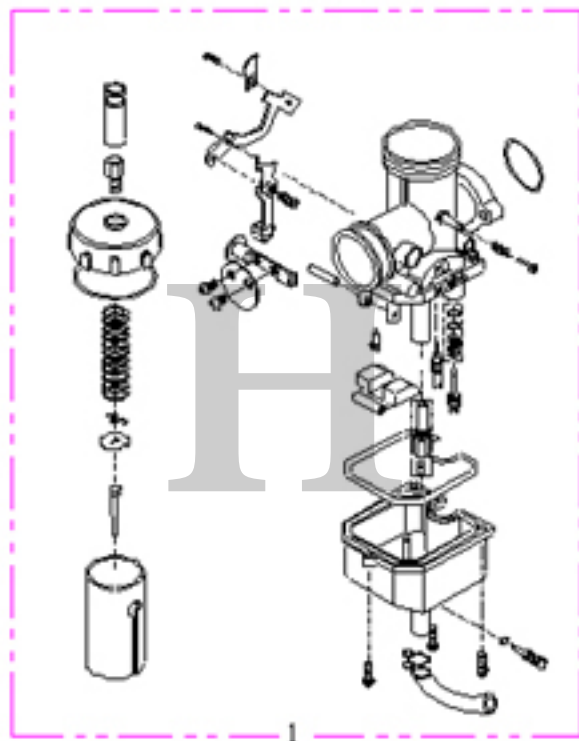

序號	零件號碼	中文名稱	規格	配賦量	售價 (含稅)	備註
				HD-125K		
No.:	Part No.:	Name	Spec.	Q'ty	Price	Remark
01	1241201001	化油器組	PD026A	1	2651	

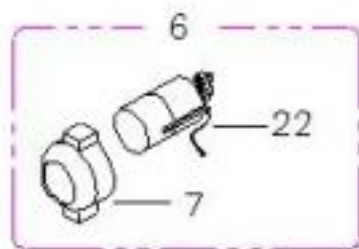

H

序號	零件號碼	中文名稱	規格	配賦量	售價 (含稅)	備註
				HD-125C		
No.:	Part No.:	Name	Spec.	Q'ty	Price	Remark
06	1241212000	起動開關組		1	285	
07	1241215000	起動開關護套	HORIZOTAL	1	23	
22	1241218000	起動開關		1	266	

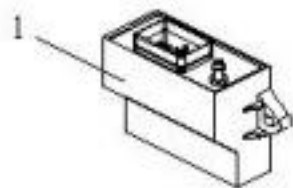

序號	零件號碼	中文名稱	規格	配賦量	售價	備註	
				HD-125C	(含稅)		
No.:	Part No.:	Name	Spec.	Q'ty	Price	Remark	
01	1261001011	電子控制單元(ECU)	16位元(含程式))_補修件用	1	3405	MC21 2030	
02	1261002000	燃油泵浦	(含濾網)	1	2031	25358415	
03	1261003000	燃油調壓閥	H	1	715	25352275	
04	1261004000	燃油噴嘴		1	1183	25360034	
05	1261005000	引擎溫度感知器		1	438	15425529	
06	1261006000	進氣溫度感知器		1	141	12160244	
07	1261007020	節流閥體		(含角度感知器) 風量調整_補修件用	1	1993	402601
08	1261008000	含氧感知器		1	2473	25325359	
09	1261009000	怠速空氣控制閥		1	707	25351449	
11	1261011001	晶體點火		1	910	300-0001340-476	
12	1261012001	燃油噴嘴蓋		1	55		